

EMERSON™

CROSBY

Crosby Style JCE Safety Relief Valves provide full overpressure protection for process systems at an affordable cost of ownership.

Design

The Crosby Style JCE Safety Relief Valve incorporates a freely pivoting disc, which ensures correct alignment with the nozzle. The combination of top guiding, unobstructed seat bore and full lift capability ensures the highest possible discharge rate thus maximum plant protection. Body material is available in cast steel and stainless steel.

The JCE Safety Relief Valve is available in both conventional and balanced bellows types, and features a special disc style for liquid application, ensuring trouble free performance. The 'conventional' arrangement is suitable for applications where the built up pressure will not exceed 10%. The conventional valve can also be used in systems where the superimposed backpressure is at a constant level (up to 80%). The 'balanced bellows' arrangement is for applications where several safety relief valves discharge into a common discharge manifold, or in any circumstances where a variable back pressure can occur, up to a maximum of 40%. Valve size ranges from DN25 to DN100 (1" to 4").

Features and Benefits

- Certified to BS6759 parts 1, 2 and 3 by SAFED.
- A.D.Merkblatt (TUV Approval).
- ASME Code Section VIII (National Board Approval), with "NB/UV" stamp.
- Stoomwezen rules A1301.
- UDT Poland.
- Chinese SQL.
- Australian standard AS1271.
- Full lift maximum discharge capability.
- Each valve individually tested and set.
- Top un-wetted guiding giving unobstructed seat bore.
- Positive re-seating with either resilient or stainless steel trim.
- Comprehensive range of accessories.
- Precision lapped stainless steel trim.
- Discharge capacity at 5% overpressure on steam duty (BS6759 & AD Merkblatt).
- Low stress springs to BS6759.



CE Marking

This range of Safety Relief Valves has been certified to the requirements of PED 97/23/EC. Set pressures below 0.5 Barg do not require certification, hence cannot be CE marked.

Style JCE Safety Relief Valve

Technical specification

Technical specifications

Crosby Style	JCE
Body Material	Cast Steel & Stainless Steel
Approvals	CE (Lloyds) acc.to PED 97/23/EC AD MERKBLATT (TUV)-Germany ASME Code Section VIII (National Board-USA) "NB/UV" Stamp BS6759 parts 1,2,3 (SAFED)-United Kingdom Stoomwezen acc.to A1301- The Netherlands UDT-Poland SQL-China Australian Standard AS1271
Top Guided	Yes
Lift	Full Lift (compressible fluids)
Size Range (Inlet)	DN25-100 (1"-4")
Size configurations (inlet x outlet)	DN25 x 40 (1" x 1 1/2") DN32 x 50 (1 1/4" x 2") DN40 x 65 (1 1/2" x 2 1/2") DN50 x 80 (2" x 3") DN65 x 100 (2 1/2" x 4") DN80 x 125 (3" x 5") DN100 x 150 (4" x 6")
Pressure Range	0.35 to 40 (barg) †
Temperature Range (°C) (with suitable material)	- 40°C to 427°C
Connections	Flanged DIN (Standard), ANSI & BS 10
Trim Options	Metal to Metal, Viton, Nitrile
Cap Options	Dome, Open lever, Packed lever, test gag

Material temperature limitations

Seat

Metal to Metal	-40°C to 427°C
Viton	-30°C to 200°C
Nitrile	-40°C to 100°C

Body

Carbon Steel	-29°C to 427°C (-10°C to 400°C for TÜV)
Stainless Steel	-40°C to 427°C

De-rated discharge coefficient Kdr

Steam/air gases

BS6759 Parts 1 and 2 & A.D. Merkblatt Approval (TÜV)	0.700
ASME Code Section VIII Approval (National Board)	0.738

Liquids

BS6759 Part 3 & A.D. Merkblatt Approval (TÜV)	0.460
ASME Code Section VIII Approval (National Board)	0.482

Orifice size (actual)

Valve size (DN)	25	32	40	50	65	80	100
Orifice area (mm ²)	415	660	1075	1662	2827	4301	6648
Orifice area (in ²)	0.64	1.02	1.67	2.48	4.38	6.67	10.30

Dimensions (mm unless otherwise stated) - Refer to drawing on page 3

	25 x 40	32 x 50	40 x 65	50 x 80	65 x 100	80 x 125	100 x 150
A	100	110	115	120	140	160	180
B	105	115	140	150	170	195	220
C1	410	455	570	615	725	815/925 ^H	925/1030 ^H
C2	445	490	605	665	785	865/965 ^H	955/1060 ^H
D	85	85	125	125	155	155	180
E	3/8"	3/8"	1/2"	1/2"	3/4"	3/4"	3/4"
F	1/4"	1/4"	1/4"	1/4"	1/4"	3/8"	3/8"
WT (kg)	8.5	14.0	20.0	30.0	42.6	64.5	86.0

Notes

H Denotes high pressure valve longer bonnet, spring and spindle

Notes

- † For maximum pressure per size and material refer to page 5 and page 6. Minimum pressure limits also apply dependant on code and application. Refer to page 5.

Style JCE Safety Relief Valve

Standard materials of construction

Flange options

Carbon/Stainless steel

PN16 (RF) x PN16 (RF)
PN40 (RF) x PN16 (RF)
 ANSI 150 (RF) x 150 (RF)
 ANSI 300 (RF) x 150 (RF)
 BS 10 : F (FF) x E (FF)
 BS 10 : J (RF) x F (FF)
 BS 10 : H (RF) x F (FF)

Notes

Standard flange connections are shown in bold
 FF = Flat Face
 RF = Raised Face

Notes

- B Denotes used on Bellows type valves.
- H High Pressure type valves and spacer and larger studs, spring and spindle.
- # Resilient trims are available. (See page 4)
- * Recommended spares.

Certified Drawings are available with material parts list.

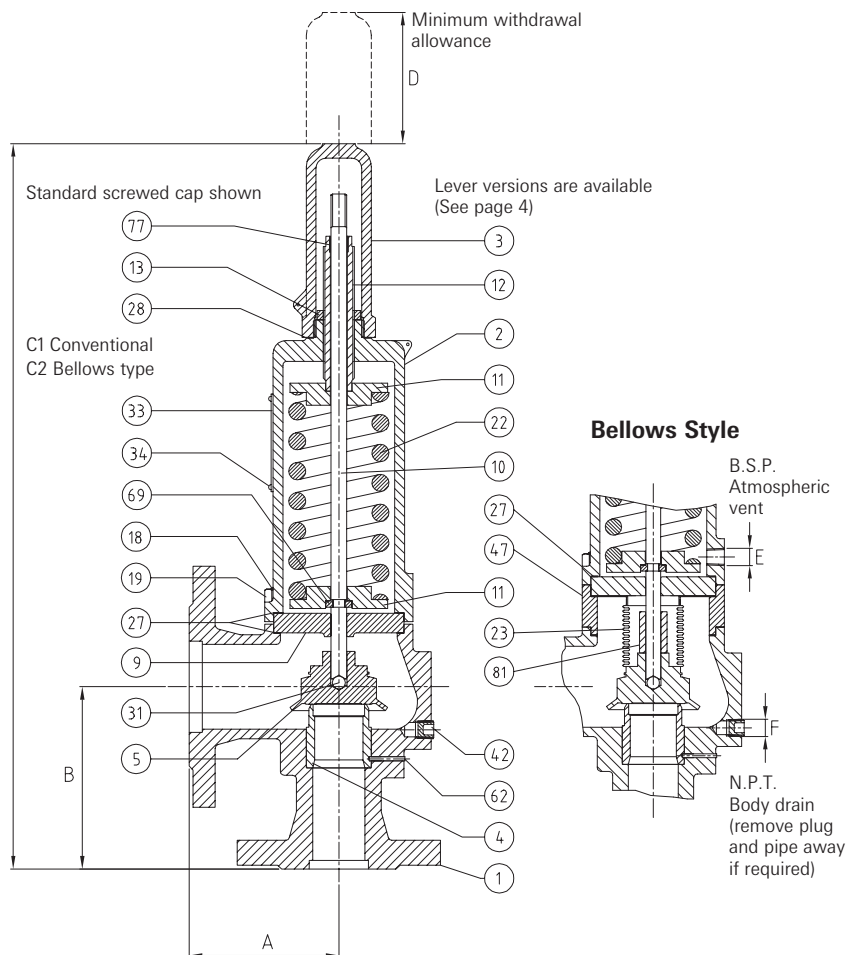

Conventional Style

Parts and Material List

Item	Part	Standard Materials (European Norm)		Equivalent Materials (ASME)	
		Carbon Steel Body (Code 2)	Stainless Steel Body (Code 3)	Carbon Steel Body (Code 2)	Stainless Steel Body (Code 3)
1	Body	C.Stl EN 10213-2 Gr.1.0619	S.Stl EN 10213-4Gr.1.4408	SA 216 Gr.WCB C.Stl	SA 351 Gr.CF8M S.Stl
2	Bonnet	C.Stl EN 10213-2 Gr.1.0619	S.Stl EN 10213-4Gr.1.4408	SA 216 Gr.WCB C.Stl	SA 351 Gr.CF8M S.Stl
3	Cap	C.Stl EN 10213-2 Gr.1.0619	S.Stl EN 10213-4Gr.1.4408	SA 216 Gr.WCB C.Stl	SA 351 Gr.CF8M S.Stl
4	Seat	S.Stl EN 10088-3 Gr. 1.4057	S.Stl EN 10088-3Gr.1.4404	SA 479 Gr.431 S.Stl	SA 479 Gr. 316L S.Stl
5 *	Disc #	S.Stl EN 10088-3 Gr. 1.4542	S.Stl EN 10088-3Gr.1.4542	SA 564 Gr.630 S.Stl	SA 564 Gr.630 S.Stl
9	Guide Plate	S.Stl EN 10088-3 Gr. 1.4029	S.Stl EN 10088-3Gr.1.4029	BSEN 10088-3 Gr.1.4029 S.Stl	BSEN 10088-3Gr. 1.4029 S.Stl
10 ^H	Spindle	S.Stl EN 10088-3 Gr. 1.4057	S.Stl EN 10088-3Gr.1.4057	SA 479 Gr.431 S.Stl	SA 479 Gr. 431.S.Stl
11	Spring Plate	S.Stl EN 10088-3 Gr. 1.4057	S.Stl EN 10088-3Gr.1.4057	SA 479 Gr.431 S.Stl	SA 479 Gr. 431.S.Stl
12	Adjusting Screw	S.Stl EN 10088-3 Gr. 1.4006	S.Stl EN 10088-3Gr.1.4006	SA 479 Gr.410 S.Stl	SA 479 Gr. 410.S.Stl
13	Locknut	S.Stl EN 10088-3 Gr. 1.4404	S.Stl EN 10088-3Gr.1.4404	SA 479 Gr.316L S.Stl	SA 479 Gr. 316L S.Stl
18 ^H	Body Stud	1.7725	1.4541	SA 193 Gr.B7 Alloy	SA 193 Gr. B8T S.Stl
19	Body Nut	1.7725	1.4541	SA 193 Gr.2H Alloy	SA 194 Gr. 8T S.Stl
22 ^H	Spring	To suit application- see page 7	To suit application- see page 7	To suit application- see page 7	To suit application- see page 7
23 ^B	Bellows Unit	S.Stl EN 10088-2 Gr.1.4404	S.Stl EN 10088-2 Gr.1.4404	S.Stl. BS 1449 Gr.316 S11	S.Stl BS 1449 Gr. 316 S11
27 *	Body/Bonnet Gasket	Compressed fibre	Compressed fibre	Compressed fibre	Compressed fibre
28 *	Cap Gasket	Compressed fibre	Compressed fibre	Compressed fibre	Compressed fibre
31 *	Ball	1.4125	1.4125	AISI 440C	AISI 440C
33	Nameplate	1.4541	1.4541	S.Stl.BS 1449 Gr.321 S31	S.Stl.BS 1449 Gr.321 S31
34	Nameplate Pin	Hardened Steel	S.Stl EN 10088-3 Gr.1.4404	Hardened Steel	SA 479 Gr.316L S.Stl
41	Warranty Seal	Lead Wire	Lead Wire	Lead Wire	Lead Wire
42	Drain Plug	1.0402	S.Stl EN 10088-3 Gr. 1.4404	BS 970 070 M20	SA 479 Gr.316L S.Stl
47 ^{B, H}	Spacing Piece	1.0402	S.Stl EN 10088-3 Gr. 1.4404	BS 970 070 M20	SA 479 Gr.316L S.Stl
62	Seat pin	1.4300	1.4300	BS 2056 Gr.302 S26	BS 2056 Gr.302 S26 S.Stl
69	Split Collar	S.Stl EN 10088-3 Gr. 1.4542	S.Stl EN 10088-3 Gr. 1.4542	SA 564 Gr.630 S.Stl	SA 564 Gr.630 S.Stl
77	Adjusting Screw bush	PTFE	PTFE	PTFE	PTFE
81 ^B	Lift Stop	S.Stl EN 10088-3 Gr. 1.4401	S.Stl EN 10088-3 Gr. 1.4401	SA 479 Gr.316 S.Stl	SA 479 Gr.316 S.Stl

Style JCE Safety Relief Valve Accessories

Open type easing gear

Valves which are used for steam or compressed air are normally fitted with open type easing gear. This type of easing gear can also be used on other fluids where a small escape of the fluid to atmosphere, when the valve is discharging, is not objectionable. It is normally fitted on conventional type valves only.

The purpose of the easing gear is to check that the valve can operate freely.

Parts list

Item no.	Part name
3	Open type bonnet
56	Fulcrum pin
61	Spindle nut
73	Marine easing lever
75	Grubscrew
83	Spindle washer

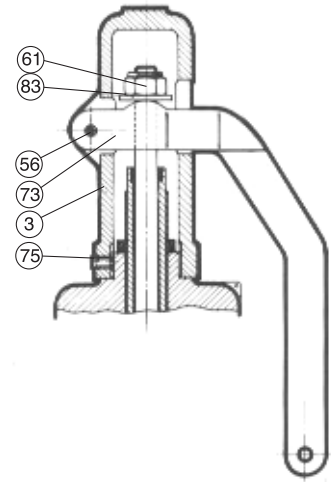

Packed easing gear

Alternatively packed easing gear can be supplied.

This is used when the fluid cannot be allowed to escape to atmosphere except through the outlet connection, but where it is necessary to check that the valve is free to operate.

Parts list

Item no.	Part name
3	Packed type bonnet
28	Cap gasket
35	Tension pin
57	Gland
58	Gland packing
61	Spindle nut
70	Eccentric shaft
73	Packed easing lever
82	Spindle lock nut

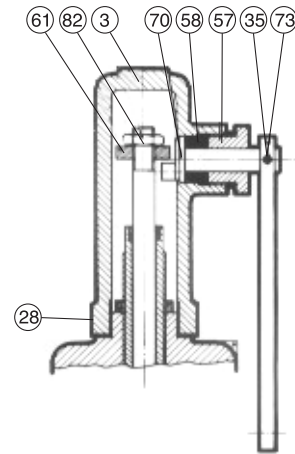

Resilient seat

The Standard construction using metal-to-metal seats lapped to high standard is suitable for most applications.

Elastomeric seals are supplied as conditions dictate.

O-ring material	Temp. range
A. Viton	-30 to 200°C
B. Nitrile	-40 to 100°C

Other materials may be available upon request

Parts list

Item no.	Part name
5	Resilient disc
53	O-ring seal
65	Circlip
66	Retaining plate

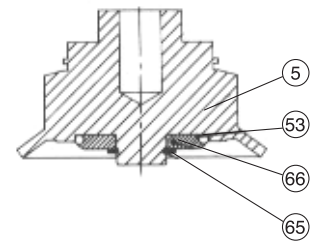

Test gag

Valves can be supplied fitted with a test gag, the purpose of which is to prevent the valve opening at the pressure when carrying out hydraulic or similar tests. It is essential to remove this gag screw after the test has been completed, and replace it with the plug which is supplied, before the valve is put in service.

Parts list

Item no.	Part name
37	Gagplug gasket
38	Gagplug
40	Gagscrew
90	Gag-nameplate

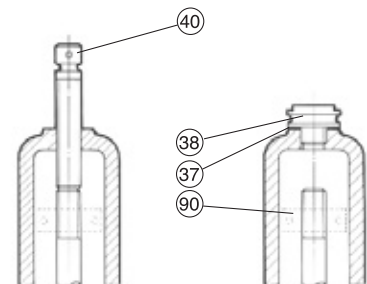

Style JCE Safety Relief Valve

Pressure limitations (set and back pressures)

Note

LP = Low pressure assembly. The maximum pressures stated are approximates only, as the pressures vary according to both flowing medium and valve type.
HP = High pressure assembly

Table 1 - Maximum pressure in relation to size

(See also graph on page 6 and steam limitations page 7)

Valve size (mm)	25	32	40	50	65	80 LP	80 HP	100 LP	100 HP
Carbon steel body	40	40	40	40	35	14	32	12	25
Stainless steel body	40	40	40	40	35	14	32	12	25

Minimum set pressure settings

Minimum Spring Settings (barg) - Conventional Style

All Sizes 0.35 barg (acc. to BS 6759 or other non-code applications)

Minimum Spring Setting (barg) - Balanced Bellows Style*

Valve size (DN)	Gas, Vapour, Steam		Liquids	
	Maximum Back Pressure (% of Set Pressure)		Maximum Back Pressure (% of Set Pressure)	
	0 to 20 %	20 to 40 %	0 to 20 %	20 to 40 %
25	1.18	2.40	1.18	2.40
32	2.20	2.63	4.48	5.52
40	0.71	2.44	0.71	2.44
50	0.96	2.22	0.96	4.70
65	1.03	4.01	1.03	4.01
80	1.27	4.09	1.27	4.09
100	1.69	2.00	2.07	2.55

* Irrespective of minimum code or conventional style valve designs, the listed minimum spring settings for balanced bellows style JCE safety relief valves are the governing minimum settings dependant on fluid and extent of actual back pressure.

Minimum Certified Set Pressure Settings (barg)

for VdTUV Certified JCE Safety Relief Valves

Valve Size (DN)	25	32	40	50	65	80	100
Conventional Style	1.00	1.00	1.00	1.00	1.00	1.73	1.00
Bellows Style**	2.25	4.48	1.98	1.99	2.59	3.72	2.07

** Unless limited by back pressure as in main governing tabulation above

Minimum Certified Set Pressure Settings (barg)

for ASME VIII NB/UV Certified JCE Safety Relief Valves

All Sizes and Styles: 15 PSIG / 1.03 barg (unless limited by governing tabulations above)

Minimum Certified Set Pressure Settings (barg)

for PED 97/23/EC certified (CE Marked) JCE Safety Relief Valves

All Sizes and Styles: 0.50 barg (Unless limited by governing tabulations above)

Notes

- (i) For pressures below the recommended minimum please refer to the factory
- (ii) For back pressures in excess of 40% please refer to the factory
- (iii) For temperatures outside those stated please refer to factory

For all variable superimposed back pressure applications a balanced bellows valve is required.

Back Pressure

The maximum allowable back pressures are as follows:

For a conventional valve

Built up back pressure	: 10% of set pressure (gauge)
Constant superimposed back pressure	: 80% of set pressure (gauge)
Variable superimposed back pressure	: 0% of set pressure

For a balanced bellows valve

Built up back pressure	: 40% of set pressure (gauge)
Constant superimposed back pressure	: 40% of set pressure (gauge)
Variable superimposed back pressure	: 0-40% of set pressure (gauge)

Actual Back Pressure Limit

Limit is either stated percentage of inlet pressure or outlet flange rating whichever is the lowest (conventional and bellows styles).

Valve performance

Over pressure

The table below specifies the required over pressure to achieve the rated valve lift and the recommended minimum valve set pressures.

Valve type	Conventional	Balanced bellows	Resilient	Resilient balanced bellows
Set pressure	1 bar to MR	2 - 3 bar 3 bar to MR	1 - 6 bar 6 bar to MR	2 - 6 bar 6 bar to MR
% over pressure	5%	10% 5%	10% 5%	10% 5%

MR = Maximum rating

Style JCE Safety Relief Valve

Maximum pressure/temperature ratings for inlet flange

Crosby Style JCE Safety Relief Valve maximum inlet pressure/temperature ratings

Carbon and stainless steel valve bodies with inlet flange acc. to standards
 DIN 2401 (1.66) or BS 4504 PN40 and ANSI B16.5 Cl.300 RF

Note: 40 barg is maximum set pressure irrespective of selected flange

Standard ratings apply for PN16 and Cl. 150 RF flange selections

Refer all other flange standards

For VdTÜV Certification carbon steel (1.0619) is limited to -10° to + 400°C

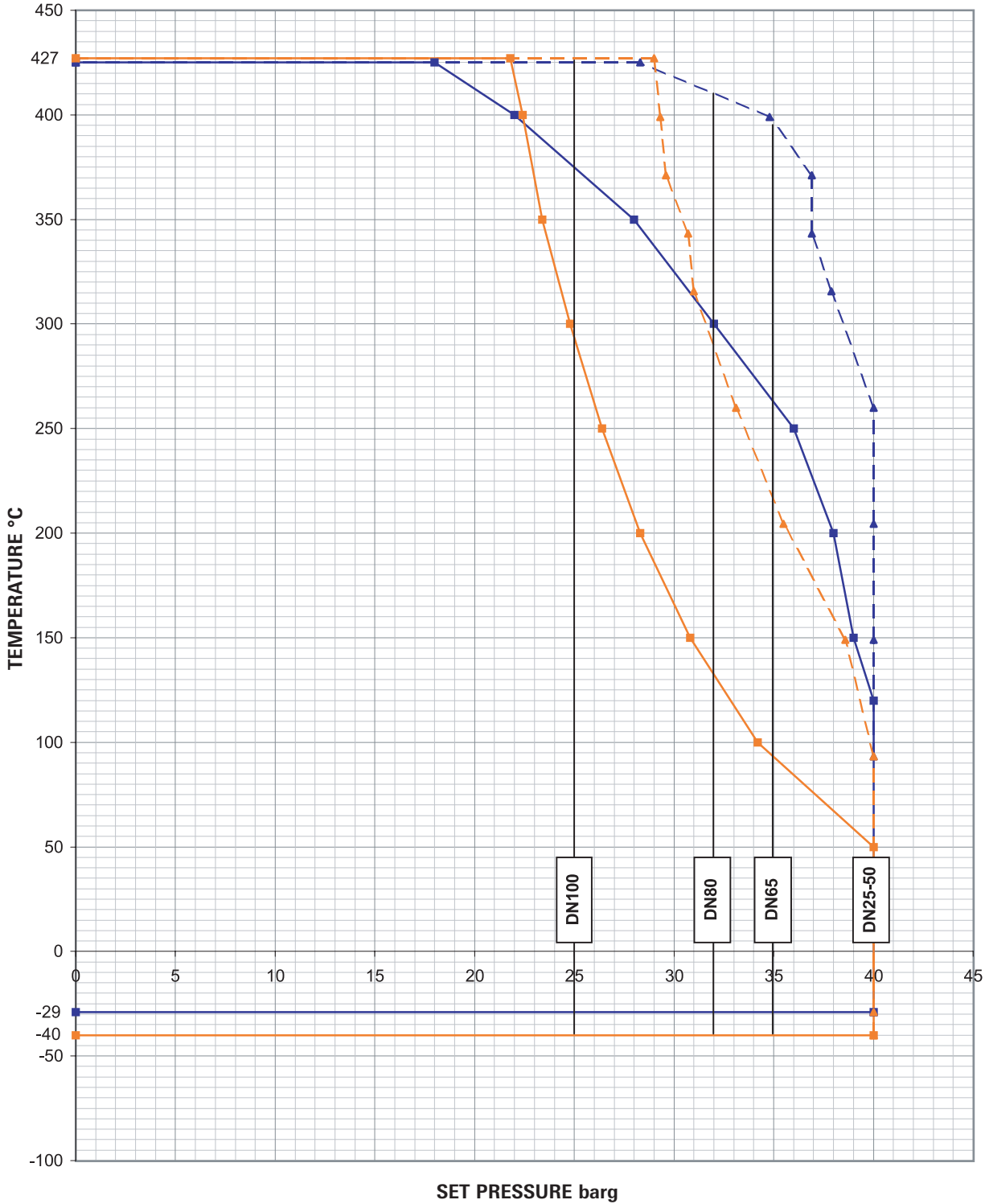

- Carbon Steel Flange Limits (BS4504/DIN2401(1.66))
- Stainless Steel Flange Limits (BS4504/DIN2401(1.66))
- -▲- Carbon Steel Flange Limits (ASME B16.5)
- -▲- Stainless Steel Flange Limits (ASME B16.5)

Body Materials

Carbon Steel (Code 2)

- EN 10213-2 Grade 1.0619
- Equivalent ASME material ASME SA 216 Grade WCB

A commonly used material suitable for a wide range of fluids when corrosion and extremely low or high temperatures do not present a problem.

Temperature limits : - 29 to + 427°C (-10°C to 400°C for TÜV)

Maximum pressure cold rating : 40 Bar (up to 50 mm, refer to table 1 on page 5 and graph on page 6)

Maximum Pressure for Steam : 40 barg up to DN50
34 barg up to DN65
32 barg up to DN80
25 barg up to DN100

Austenitic Stainless Steel (Code 3)

- EN 10213-4 Grade 1.4408
- Equivalent ASME Material ASME SA 351 Grade CF8M

A very widely used Stainless Steel recognized for its excellent corrosion resistant properties in the presence of chlorides.

Temperature limits : - 40 to 427°C

Maximum pressure cold rating : 40 Bar (up to 50 mm, refer to table 1 on page 5 and graph on page 6)

Maximum Pressure for Steam : 40 barg up to DN50
34 barg up to DN65
32 barg up to DN80
25 barg up to DN100

Spring applications

Chrome Vanadium to BS 970 735 A51

For use normally with carbon steel valves.

Application: normal temperature, non corrosive duty.

Tungsten to BS 4659 BH 12

For use normally with carbon steel valves.

Application: high temperature non corrosive duty.

Stainless steel 316 to BS 970 316 S31

For use normally with carbon steel or stainless steel valves.

Application-low/normal temperature, corrosive duty.

Stainless Steel 17/4 to BS 25143

For use normally with carbon steel or stainless steel valves.

Application: high temperature, corrosive and all sour gas duties.

Inconel X750 to ASTM A 638 GRADE 660

For use normally with stainless steel valves.

Application: high temperature corrosive and sour gas duty (where 17/4 is not practical due to design limitations).

Spring Materials

There are several spring materials available, the choice of material being dependent on the application.

The JCE range of springs have been designed and manufactured in accordance with BS 6759 Part1: 1984.

The following benefits are gained from this design:

1. Negligible relaxation due to temperatures because of tight control of stress limitation and material selection.
2. Accurate end grinding ensures tight shut off and high level of repeatability.
Control of coil spacing ensures reliable pressure range and full lift capability.

Table 2

Spring material	Fluid temperature range
Chrome vanadium	-29°C to + 232°C
Tungsten steel (H12)	+232°C to +370°C
Stainless steel (316)	-40°C to +260°C
Stainless steel (17/4) *	-40°C to + 427°C
Inconel X750	-40°C to + 427°C

* Used to meet NACE requirements. In hardness range equal to or less than 33 HRC.

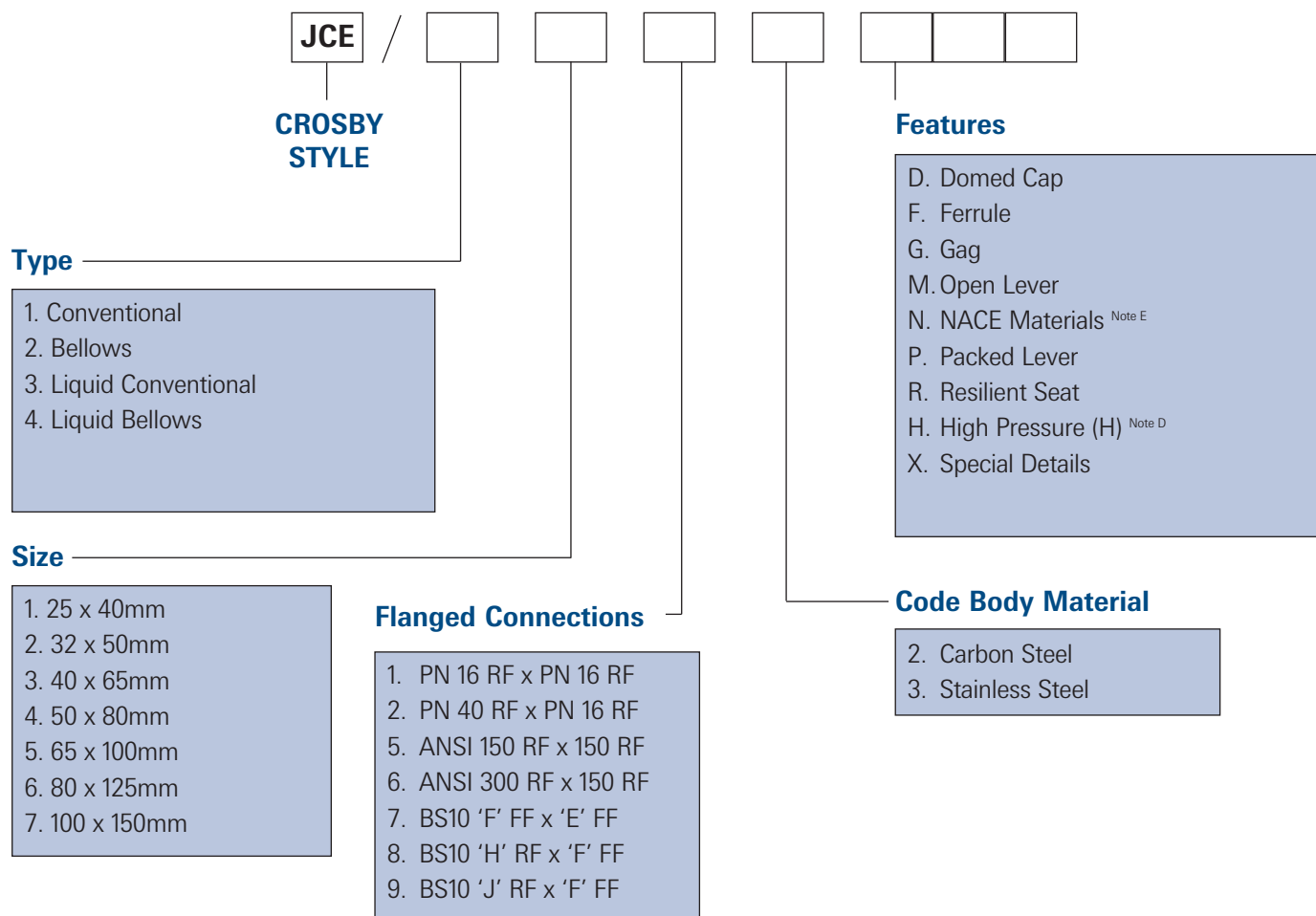

Notes

- A. In addition to the above valve code we need to know the following information: set pressure, flowing medium and temperature.
- B. Any special requirements will be indicated by the letter X which will be agreed with the sales office. For example, paint specification or spring material.
- C. Any combination of features can be called up eg. DG, PR, DFRN etc.
- D. 'H' for 80 and 100 mm size only.
- E. NACE MR-01-75, 2002 edition.

Examples

- a. **JCE / 2 4 2 2 P**
(Set at 20 barg and 5 barg variable back pressure, vapour service, 90°C)
2 - Bellows type JCE (Standard gas trim)
4 - DN 50 x 80 (inlet x outlet) size
2 - Flanged PN 40 x PN 16
2 - Carbon steel body construction
P - Packed lifting lever
- b. **JCE / 3 7 5 3 D R**
(Set at 90 psig, distilled water, 80°F)
3 - Conventional type JCE (liquid trim)
7 - DN 100 x 150 (inlet x outlet) size (or 4" x 6")
5 - Flanged ANSI CL.150RF x CL 150RF
3 - Stainless steel construction
D - Domed cap
R - Resilient seat (Option- specify material)

Installation

Safety Relief Valves should always be installed in an upright position with their spring chamber vertical. All packing materials should be removed from the valve connections prior to installation.

Pressure Vessels

When fitting a Safety Relief Valve onto pressure vessels, the inlet connection pipe should be as short as possible and the bore should be at least equivalent to the nominal bore size of the valve.

The pressure drop between the vessel and the valve should be no more than 3% at rated capacity.

Inlet pipe sizing

The Style JCE Safety Relief Valve is a full lift design having inlet seat area approximately 85% of the inlet pipe connection area.

For this reason inlet pressure loss should be carefully considered when sizing pipework, and normally pipework in excess of the valve inlet will be required.

Pressure-tight dome

A pressure-tight dome should be specified when:

1. A backpressure must be contained within the relieving system.
2. A head of liquid is built up within the valve body and consequently needs to be contained.
3. The relieving medium is toxic, corrosive or environmentally unfriendly.

System Cleansing

It is essential that new installations are fully flushed and all debris removed prior to installing the valve as serious damage can be caused to valve seats, resulting in subsequent leakage.

Pressure Adjustment

Every valve is fitted with a suitable spring and tested before leaving the factory. Valves can be preset on request but to alter the set pressure, the adjusting screw, when viewed from the top, should be screwed downwards in a clockwise direction to increase the set pressure and upwards in an anti-clockwise direction to decrease it. Set pressure adjustment must be carried out by experienced and approved personnel. Any change in set pressure must be within the range of the existing spring, if it exceeds the range, a new spring will be required. The cap lead seal must be re-made after any adjustment to the set pressure. Adjustments made by unauthorized personnel will invalidate the warranty of the valve.

Pipelines

When fitting a Safety Relief Valve into a pipeline, the inlet connecting pipe leading from the main pipeline to the Safety Relief Valve should be as short as possible, so that the inlet pressure drop is no more than 3% of rated capacity.

In addition, it is advised that the Safety Relief Valve is placed a sufficient distance downstream of the pressure source. This will protect the valve from the adverse effects of pressure pulsations.

Discharge Pipelines

These should be equal to or larger than the valve outlet, with adequate supports, minimum number of bends and overall length. Unless balanced bellows valves are installed, the maximum built up backpressure should not exceed 10% of the set pressure, although the JCE can handle higher back pressure if required. Steam service valves should be adequately drained. Alignment of the discharge or drain should present no risk to persons or property. Protection from the collection of rainwater or condensation in the discharge pipe is advisable.



Important

These notes are for guidance only and do not replace our standard installation manual n°ES/0/146

Cold differential test pressure

When setting a valve intended for use at high temperature on a test rig using a test fluid at ambient temperatures, it is necessary to set the valve at a slightly higher pressure, so that it will open at the correct set pressure under operating conditions.

The necessary allowance is shown in the following table:

Operating temperature - Centigrade	% Increase in set pressure at ambient temperature
Up to 121°C	None
122°C to 316°C	1
317°C to 427°C	2