

## CROSBY J-SERIES

### DIRECT SPRING PRESSURE RELIEF VALVES

J-Series valves provide high quality and dependable overpressure protection for air, gas, steam, vapor, liquid and two-phase applications in one simple design



#### FEATURES

- ASME/NB certified capacities for air, water and steam.
- Full compliance with all major global pressure relief standards including ASME VIII, API 526/527, EN4126 and PED/CE.
- Highly customizable to meet most applications.
- Interchangeable parts to reduce maintenance costs.
- Full nozzle configuration.
- Simple and reliable design.
- Easy maintenance.
- Soft seat options for superior seat tightness.
- Adjustable blowdown to reduce product loss.

#### GENERAL APPLICATION

The J-Series pressure relief valve provides overpressure protection from very basic to the most demanding applications. Backed by over 140 years of engineering and application experience, its versatile and rugged design make it a proven solution for oil and gas, process and power industry overpressure protection.

#### TECHNICAL DATA

Sizes:	1" D 2" to 12" W 16"
Orifices:	0.110 to 60.75 in <sup>2</sup> (71 to 39,193 mm <sup>2</sup> )
Inlet ratings:	ANSI Classes 150, 300, 600, 900, 1500, 2500
Temperature range:	-450°F to +1000°F (-268°C to +538°C)
Set pressures	
JOS-E:	5 to 6000 psig (.034 to 413.79 barg)
JLTJOS-E:	15 to 6000 psig (1.03 to 413.79 barg)
JBS-E:	15 to 6000 psig (1.03 to 413.79 barg)
JLTJBS-E:	25 to 6000 psig (1.72 to 413.79 barg)
Code:	ASME Section VIII (15 psig and above)

# CROSBY J-SERIES

## DIRECT SPRING PRESSURE RELIEF VALVES

---

### CONTENTS

---

Introduction/description .....	2
Models range .....	5
O-ring soft seats .....	16
Variations from standard materials .....	17
Caps and lifting levers .....	19
Sizes, dimensions and pressure/temperature limits.....	22
Capacity tables (U.S.C.S.).....	56
Equivalents and conversion factors.....	69
Capacity tables (metric).....	70
Block body relief valves .....	82
Ordering information .....	84
Valve sizing .....	88

### PRODUCT RANGE

---

Series JOS-E and JLTJOS-E are the standard conventional relief valve designs for applications when the discharge is to the atmosphere or to a low pressure exhaust system designed to contain the process fluid.

Series JBS-E and JLTJBS-E pressure relief valves incorporate a bellows which is balanced to minimize the effects of variable back pressure on valve set pressure and can also handle applications involving high built-up back pressure.

For liquid service applications, Series JLTJOS-E and JLTJBS-E provide stable operating performance using our industry-recognized patented liquid trim design, which allows the valve to achieve full lift at 10% overpressure without valve chatter.

Series JOS-H-E are open bonnet pressure relief valves intended for ASME Code Section VIII steam service applications and are furnished with a regular lifting lever as standard.

Series JBSBP-E and JLTJBSBP-E are balanced bellows valves with a supplementary back pressure balancing piston.

Series JOS-E-B and JBS-E-B are BlockBody pressure relief valves that provide a cost-effective alternative to multiple high pressure smaller orifice valves.

J-Series capacities are certified by the National Board of Boiler and Pressure Vessel Inspectors.

Their castings and forgings are procured to ASME/ASTM material specifications and are available in a number of material combinations such as Monel®, Hastelloy® and stainless steel in addition to a number of special material combinations such as titanium, duplex stainless steel and Inconel®, which are available on application.

Dimensions of flanges conform to current ASME Standards. All steel raised face flanges are spiral concentric serrated finish with 45 to 55 grooves per inch and a finish between 125 Ra and 200 Ra. Other flange facings, such as ring type joint, are available on request.

# CROSBY J-SERIES

## DIRECT SPRING PRESSURE RELIEF VALVES

### SEAT DESIGN

Series JOS-E and JBS-E relief valves are available with flat metal-to-metal or soft seats. Their two-piece disc holder/disc insert construction provides thermal balancing assuring maximum seat tightness and meets the requirements of API Standard 527, 'Seat tightness of pressure relief valves'.

Where system operating conditions permit, soft or elastomer O-ring seat construction is available as an option. This two-seat design (Figure 1) has a metal-to-metal seat located downstream of the soft seat. The O-ring is the primary seal. The flat metal-to-metal seat controls the compression of the O-ring and also serves as a secondary seal should the O-ring be damaged. Elastomeric O-ring soft seat valves are tightness tested at 95% of set pressure, exceeding the requirements of API Standard 527.

Standard O-ring materials include Viton®, Buna-N, EPR, TFE, silicone rubber and Kalrez® (see page 16). Other soft seat materials, their pressure and temperature limits are available on application.

### DUAL CERTIFICATION

Series JLT pressure relief valves for liquid service were developed using our unique patented trim design. This contoured liquid trim design (Figure 2), with over 25 years of successful field experience, was patented prior to the issuance of ASME Code Section VIII requirements that became mandatory in 1985. The JLT trim offers a significant increase in capacity at 10% overpressure and, in many cases, results in selection of a smaller valve with an associated reduction in inlet and discharge piping costs.

The JLT design is also capacity certified for gas and vapor service and can be applied in two-phase flow applications. The JLT design is a logical choice where the process fluid may be a liquid or gas depending on the overpressure condition.

### BELLOWS CONVERTIBILITY

The flanged, spring operated pressure relief valve is designed and manufactured as a conventional valve and a balanced bellows valve. The conversion from conventional Series JOS-E or JLTJOS-E in sizes 1" D 2" through 8" T2 10" requires only the addition of a bellows assembly and bellows tail-piece gasket. No other parts are necessary.

### BELLOWS AND TOP FLANGE

All standard JBS-E and JLTJBS-E valves feature a standard bellows and top flange (Figure 3) manufactured from Inconel® alloy 625, which is a fatigue-resistant material and provides improved corrosion resistance compared to 316L stainless steel. It is highly resistant to pitting, crevice corrosion and inter-granular attack.

The standard bellows assembly threads onto the disc holder with a bellows tailpiece and gasket. A welded bellows attachment is available as an option.

FIGURE 1

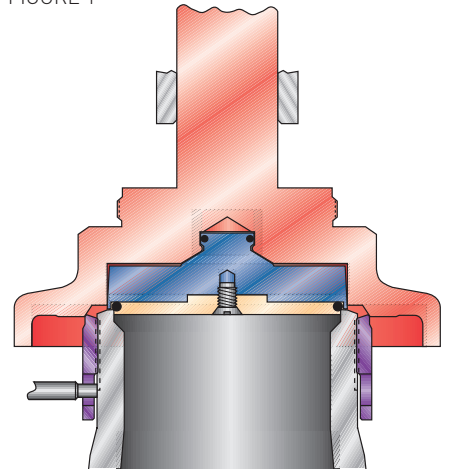

FIGURE 2

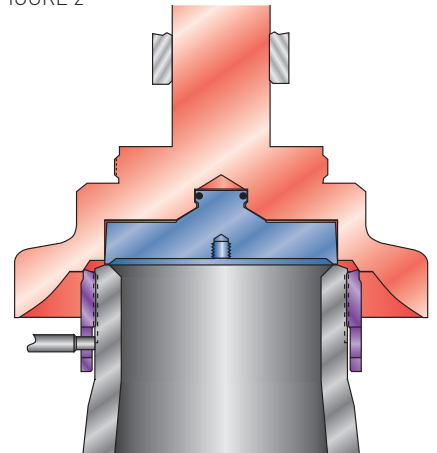
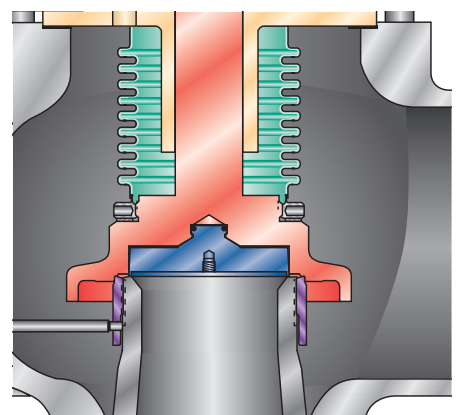

FIGURE 3



### NOTE

Viton® is a registered trademark of DuPont Performance Elastomers L.L.C.

# CROSBY J-SERIES

## DIRECT SPRING PRESSURE RELIEF VALVES

### EASE OF MAINTENANCE AND COMPONENT INTERCHANGEABILITY

The JOS-E and JBS-E's disc insert retention, disc holder and nozzle ring have been engineered to ensure ease of maintenance, minimize spare parts and provide a high degree of component part interchangeability (Figure 4).

The disc insert is held securely in place with a compressible retention clip. A 'universal' disc holder allows simple and cost effective conversions from conventional to balanced bellows design and enables cost-effective bellows replacement.

The nozzle ring encloses the adjustment slot at the bottom of the ring giving a rugged, durable design.

### CAP, LIFTING LEVER AND SPINDLE INTERCHANGEABILITY

All JOS-E and JBS-E relief valves (except restricted height caps) use a threaded spindle and drilled and tapped bonnet which permits easy cap or lifting lever conversions, with maximum standardization and interchangeability of parts. In addition, standard cap and lifting lever designs can be used with in-line test devices.

### CERTIFICATIONS AND TYPE APPROVALS

- ASME Boiler and Pressure Code Section VIII
- National Board of Boiler and Pressure Vessel Inspectors Capacity Certifications
- Canadian Registration Number
- Pressure Equipment Directive (97/27/EC), (ISO-4126-1) (CE)
- China Manufacturing License (TS)
- United States Coast Guard (USCG)
- Australia (AS-1271)

Contact your local sales representative for further details.

### AVAILABLE OPTIONS

#### Materials

- Special materials Alloy 20, duplex, titanium etc.
- Xylan coating inside body/bonnet/cap
- Spring coatings and platings
- Materials of construction for applications above 1000°F (538°C)
- Special gasket materials including graphite, Hastelloy®, PTFE etc.

#### Connections

- 300# cosmetic or fully rated non-standard outlets
- Special connections such as tri-clamp, Grayloc etc.
- International flange standards
- Flat face and RFSF flange options

#### Accessories

- Position indicator, proximity switch, etc.
- Steam jacketed bodies

#### Others

- High pressure forged block body design
- Special painting or coating
- Special cleaning and testing
- Welded disc holder
- Lethal service construction

FIGURE 4

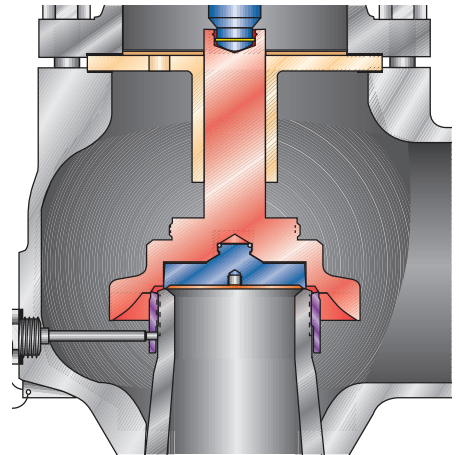

# CROSBY J-SERIES

## DIRECT SPRING PRESSURE RELIEF VALVES

### SERIES JOS-E/JLTJOS-E PRODUCT OVERVIEW

Series JOS-E and JLTJOS-E are the standard conventional relief valve designs for applications when the discharge is to the atmosphere or to a low pressure exhaust system designed to contain the process fluid.

Their exceptionally rugged design features a high guiding surface ratio and corrosion resistant trim.

For liquid service applications, Series JLTJOS-E provide stable operating performance using our industry-recognized patented liquid trim design, which allows the valve to achieve full lift at 10% overpressure without valve chatter.

#### Temperature range

JOS-E and JLTJOS-E ( )5:	-20°F to 650°F (-29°C to 343°C)
JOS-E and JLTJOS-E ( )6:	651°F to 800°F (344°C to 427°C)
JOS-E and JLTJOS-E ( )7:	801°F to 1000°F (428°C to 538°C)

SERIES JOS-E  
(with metal-to-metal seat)

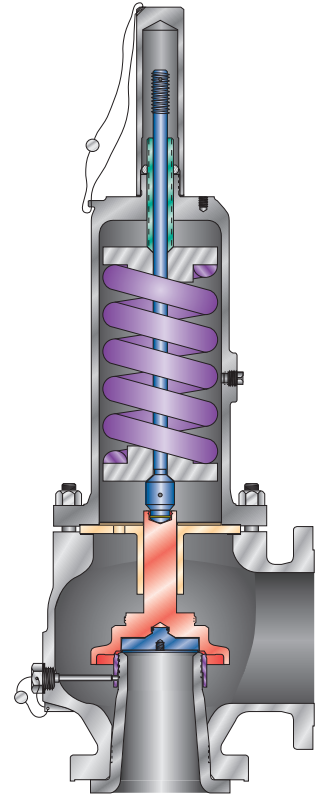

SERIES JLTJOS-E  
(with O-ring seat)

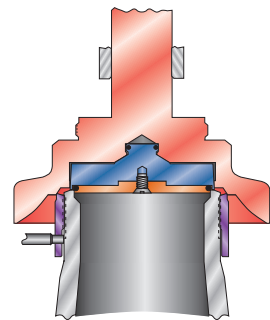

# CROSBY J-SERIES

## DIRECT SPRING PRESSURE RELIEF VALVES

### SERIES JOS-E AND JLTJOS-E STANDARD MATERIALS OF CONSTRUCTION

No.	Part name	Standard material
1	Body - JOS-E and JLTJOS-E ( )5 and ( )6	ASME SA216 Gr. WCB/WCC
1	Body - JOS-E and JLTJOS-E ( )7	ASME SA217 Gr. WC6
2	Nozzle	316 SS
3	Nozzle ring	316 SS
4	Set screw	316 SS
5	Disc holder	316L SS
8	Disc insert <sup>(1)</sup>	316 SS
9	Retention clip <sup>(2)</sup>	Inconel® X750
10	O-ring <sup>(1)</sup>	Specify
11	O-ring retainer	316 SS
12	Retainer screw(s)	18-8 SS
15	Guide	ASTM A297 Gr. HE SST
16	Spindle	416 SS
17	Spindle cotter pin	SS
18	Spring - JOS-E and JLTJOS-E ( )5	Chrome Steel <sup>(3)</sup>
18	Spring - JOS-E and JLTJOS-E ( )6 and ( )7	Alloy Steel <sup>(3,4)</sup>
19	Spring washers	CS
20	Bonnet - JOS-E and JLTJOS-E ( )5 and ( )6	ASME SA216 Gr. WCB/WCC
20	Bonnet - JOS-E and JLTJOS-E ( )7	ASME SA217 Gr. WC6
21	Bonnet stud	ASME SA193 Gr. B7
22	Bonnet stud nut	ASME SA194 CL 2H
24	Adjusting bolt	316 SS <sup>(5)</sup>
25	Adjusting bolt nut	316 SS
26	Nameplate (not shown)	SS
27	Set screw gasket <sup>(1)</sup>	316 SS
28	Guide gasket <sup>(1)</sup>	316 SS
30	Pipe plug (bonnet)	CS
34	Seal and wire	Lead and SS
35	Seal clip (not shown)	SS
40	Threaded cap	CS
41	Cap gasket <sup>(1)</sup>	316 SS

#### NOTES

1. Recommended spare part.
2. Furnished with disc insert.
3. Corrosion resistant coating.
4. Crosby may upgrade to Inconel® X750.
5. Class 900#, 1500# and 2500# inlet ratings use 416 SS.

**CROSBY J-SERIES**  
 DIRECT SPRING PRESSURE RELIEF VALVES

SERIES JOS-E AND JLTJOS-E CONVENTIONAL PRESSURE RELIEF VALVES

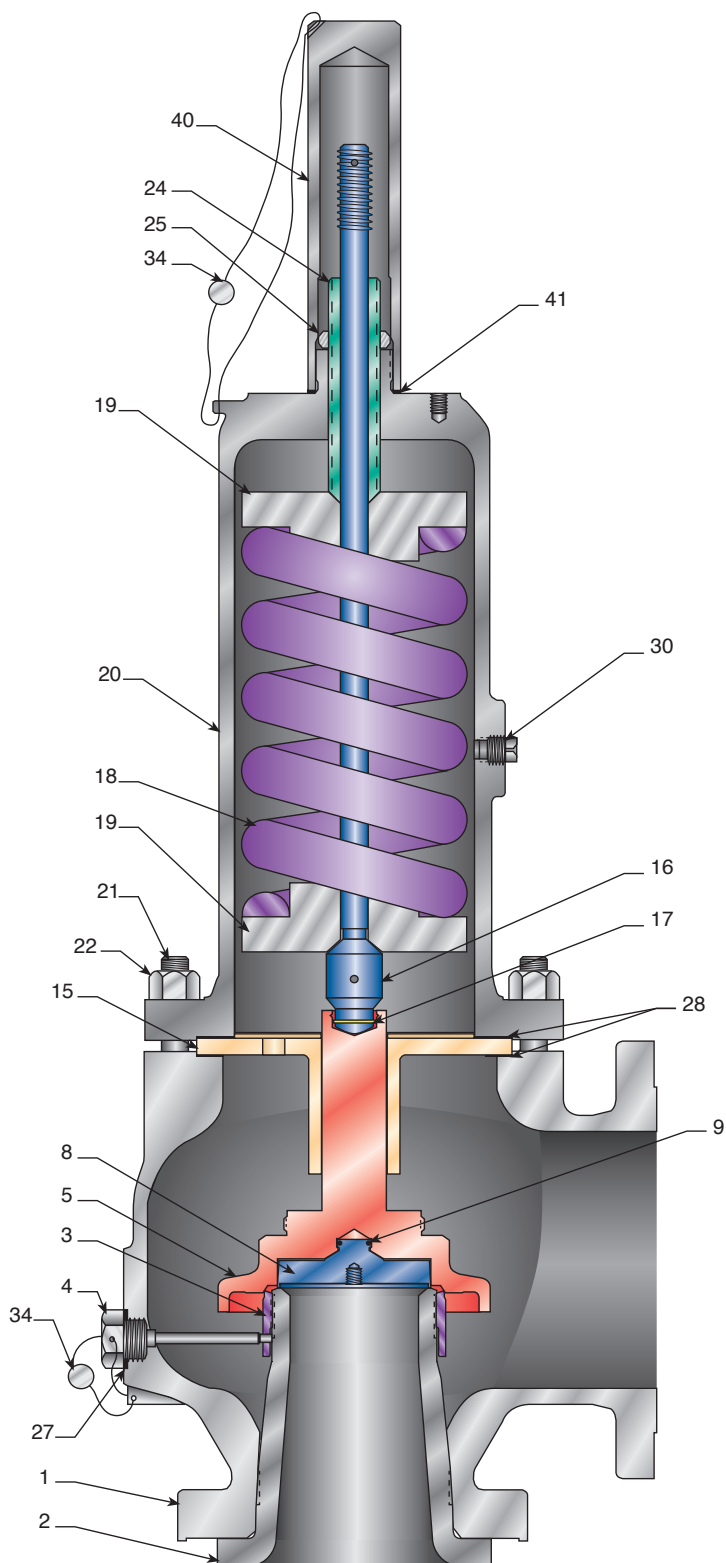

SERIES JOS-E  
 (with metal-to-metal seat)

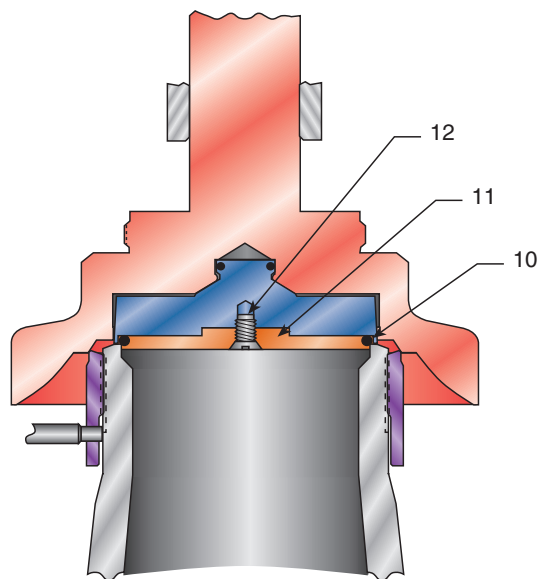

SERIES JLTJOS-E  
 (with O-ring seat)

# CROSBY J-SERIES

## DIRECT SPRING PRESSURE RELIEF VALVES

### SERIES JBS-E/JLTJBS-E PRODUCT OVERVIEW

Series JBS-E and JLTJBS-E pressure relief valves incorporate a bellows which is balanced to minimize the effects of variable back pressure on valve set pressure and can also handle applications involving high built-up back pressure.

Additionally, the bellows serves to isolate the guide, spindle, spring and other parts contained in the bonnet chamber from corrosive fluids or media such as a highly viscous fluid or slurry which could render the relief valve inoperative.

Their exceptionally rugged design features a high guiding surface ratio and corrosion resistant trim.

For liquid service applications, Series JLTJBS-E provides stable operating performance using our industry-recognized patented liquid trim design, which allows the valve to achieve full lift at 10% overpressure without valve chatter.

Temperature range	
JBS-E and JLTJBS-E (J5:	-20°F to 650°F (-29°C to 343°C)
JBS-E and JLTJBS-E (J6:	651°F to 800°F (344°C to 427°C)
JBS-E and JLTJBS-E (J7:	801°F to 1000°F (428°C to 538°C)

SERIES JBS-E  
(with metal-to-metal seat)

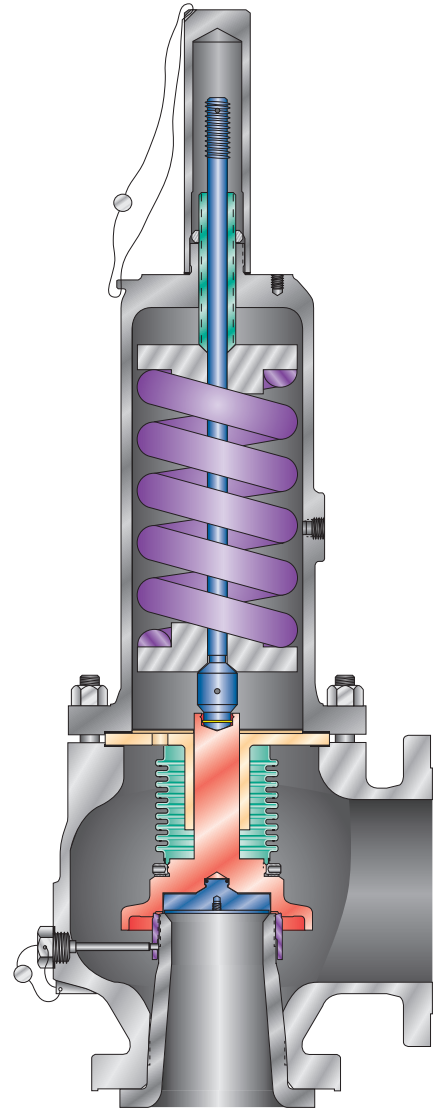

SERIES JBS-E  
(with O-ring seat)

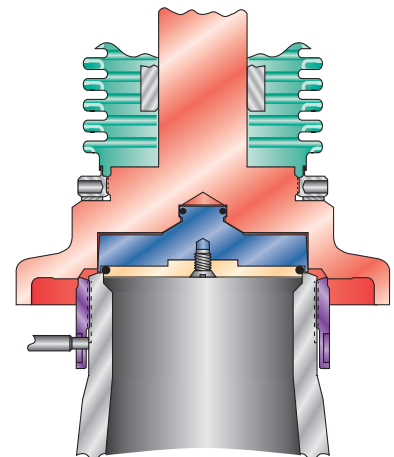



# CROSBY J-SERIES

## DIRECT SPRING PRESSURE RELIEF VALVES

### SERIES JBS-E AND JLTJBS-E MATERIALS OF CONSTRUCTION

No.	Part name	Standard material
1	Body - JBS-E and JLTJBS-E ( )5 and ( )6	ASME SA216 Gr. WCB/WCC
1	Body - JBS-E and JLTJBS-E ( )7	ASME SA217 Gr. WC6
2	Nozzle	316 SS
3	Nozzle ring	316 SS
4	Set screw	316 SS
5	Disc holder	316L SS
6A	Bellows tailpiece <sup>[1]</sup>	316L SS
6B	Bellows <sup>[1]</sup>	Inconel® 625
6C	Bellows flange <sup>[1]</sup>	Inconel® 625
8	Disc insert <sup>[2]</sup>	316 SS
9	Retention clip <sup>[3]</sup>	Inconel® X750
10	O-ring <sup>[2]</sup>	Specify
11	O-ring retainer	316 SS
12	Retainer screw(s)	18-8 SS
15	Guide	ASTM A297 Gr. HE SST
16	Spindle	416 SS
17	Spindle cotter pin	SS
18	Spring - JBS-E and JLTJBS-E ( )5	Chrome steel <sup>[4]</sup>
18	Spring - JBS-E and JLTJBS-E ( )6 and ( )7	Alloy steel <sup>[4,5]</sup>
19	Spring washers	CS
20	Bonnet - JBS-E and JLTJBS-E ( )5 and ( )6	ASME SA216 Gr. WCB/WCC
20	Bonnet - JBS-E and JLTJBS-E ( )7	ASME SA217 Gr. WC6
21	Bonnet stud	ASME SA193 Gr. B7
22	Bonnet stud nut	ASME SA194 CL 2H
24	Adjusting bolt	316 SS <sup>[6]</sup>
25	Adjusting bolt nut	316 SS
26	Nameplate (not shown)	SS
27	Set screw gasket <sup>[2]</sup>	316 SS
28	Guide gasket <sup>[2]</sup>	316 SS
29	Tailpiece gasket <sup>[2]</sup>	316 SS
34	Seal and wire	Lead and SS
35	Seal clip (not shown)	SS
40	Threaded cap	CS
41	Cap gasket <sup>[2]</sup>	316 SS

### NOTES

1. Subassembly.
2. Recommended spare part.
3. Furnished with disc insert.
4. Corrosion resistant coating.
5. Crosby may upgrade to Inconel® X750.
6. Class 900#, 1500# and 2500# inlet ratings use 416 SS.

**CROSBY J-SERIES**  
DIRECT SPRING PRESSURE RELIEF VALVES

SERIES JBS-E AND JLTJBS-E BALANCED BELLOWS PRESSURE RELIEF VALVES

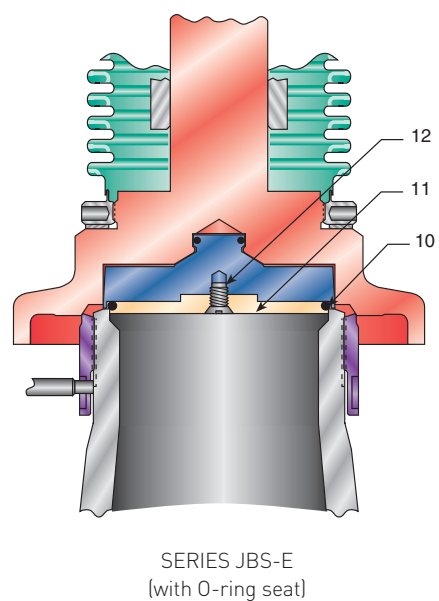
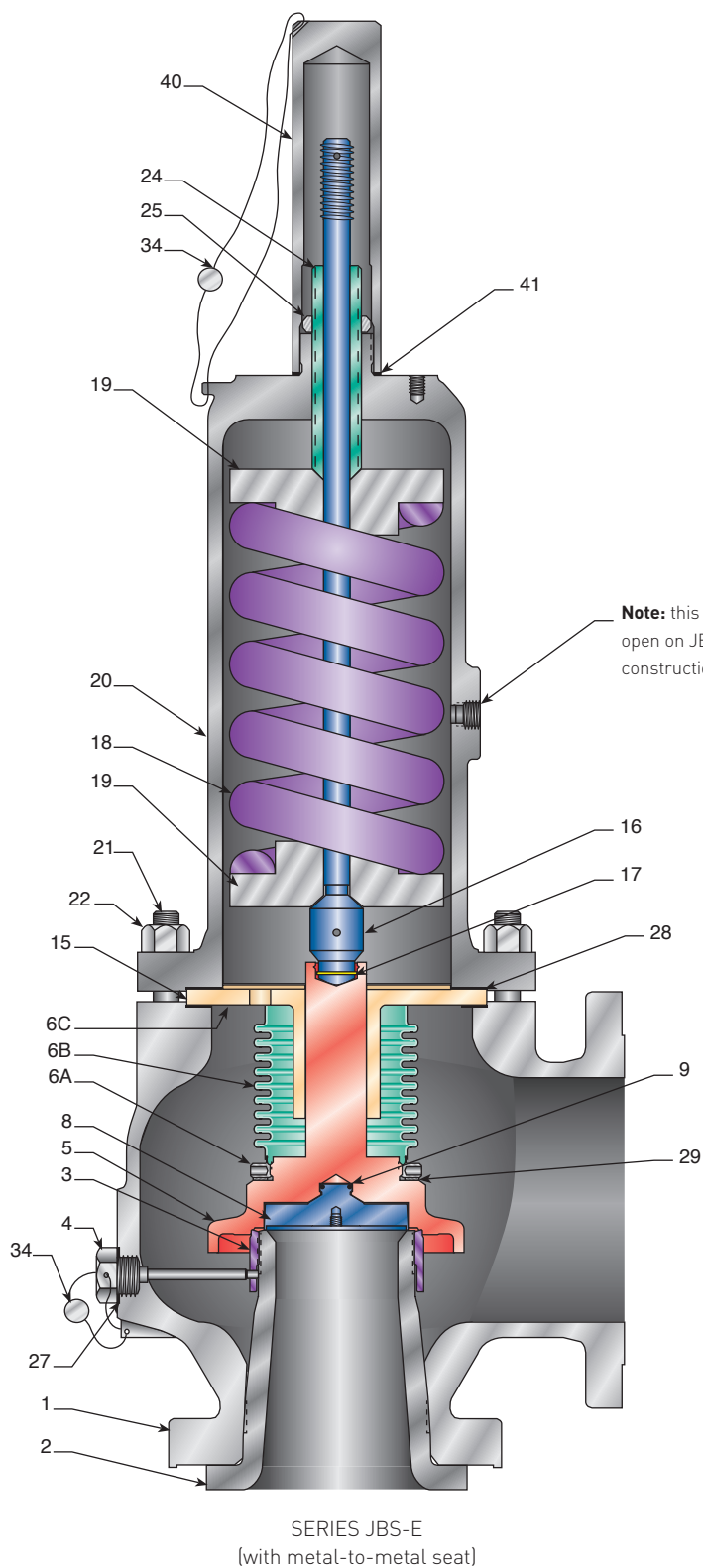

# CROSBY J-SERIES

## DIRECT SPRING PRESSURE RELIEF VALVES

### SERIES JLTJ0S-E/JLTJBS-E LIQUID TRIM PRESSURE RELIEF VALVES

Series JLTJ0S-E and JLTJBS-E pressure relief valves for liquid service were developed using our unique patented contoured trim design (Figure 5). The JLT trim offers a significant increase in capacity at 10% overpressure and in many cases, results in selection of a smaller valve with an associated reduction in inlet and discharge piping costs. It provides smooth and stable valve operation on liquid service applications.

### OPERATION

When system pressure reaches the specified set pressure, a small steady stream of fluid begins to flow from the valve. Valve disc lift at this pressure is minimal.

As the system pressure increases into the range of 3% to 5% overpressure, the valve then opens with a pop type lift to the full lift position. At 10% overpressure, the JLT valve will have attained full lift and be flowing an amount equal to or greater than the rated capacity (Figure 6).

As the system pressure begins to drop, flow through the valve decreases until the valve reseats with a clean positive closing action.

The JLT design is also capacity certified for gas and vapor service and can be applied in two-phase flow applications.

FIGURE 5

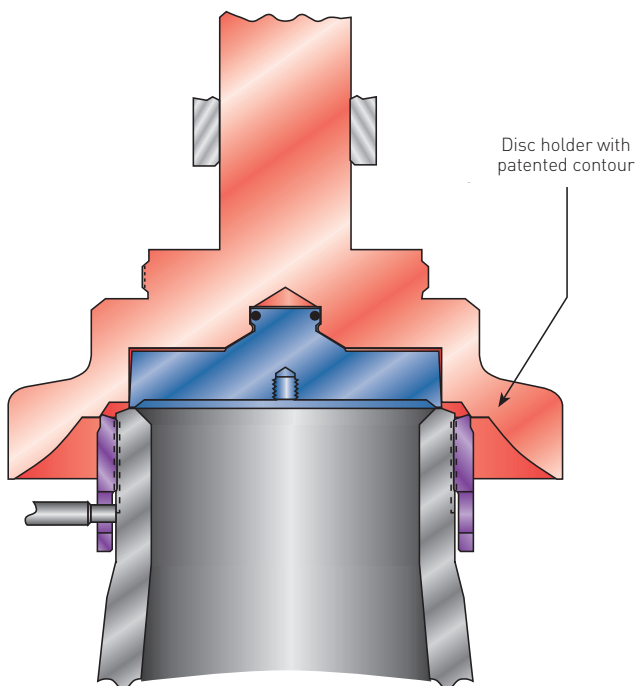
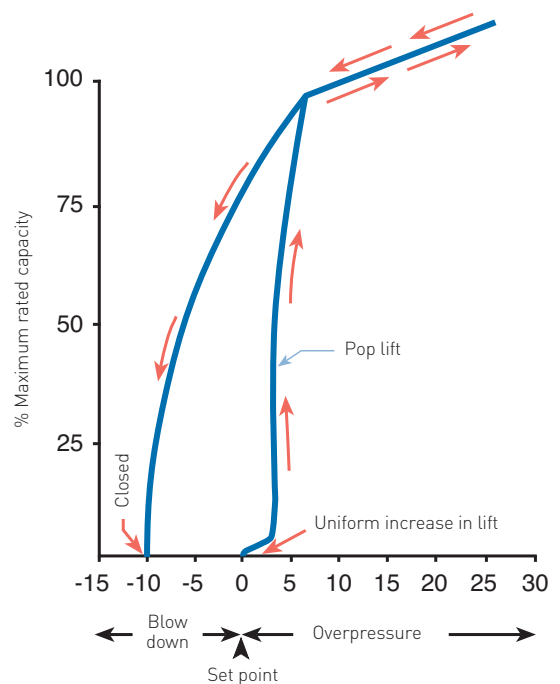

FIGURE 6  
TYPICAL FLOW CURVE - CONTOURED TRIM DESIGN (JLT)



# CROSBY J-SERIES

## DIRECT SPRING PRESSURE RELIEF VALVES

### SERIES JOS-H-E OPEN BONNET PRESSURE RELIEF VALVES

Series JOS-H-E relief valves (Figure 8) are intended for ASME Code Section VIII steam service applications and are furnished with a regular lifting lever as standard.

The standard chrome steel spring in the JOS-H-E open bonnet design is exposed for atmospheric cooling.

Optional accessories include a test rod as well as a weather hood. Materials of construction are identical to the standard closed bonnet JOS-E design.

The JOS-H-E has a maximum temperature rating of 800°F [427°C] using WCB/WCC carbon steel body and bonnet and chrome steel spring.

Series JOS-H-E (and JOS-E) relief valves for steam service at set pressures above 450 psig use a 316L stainless steel disc holder with disc bushing and threaded 17-4 ph stainless steel disc insert (see Figure 7).

FIGURE 7

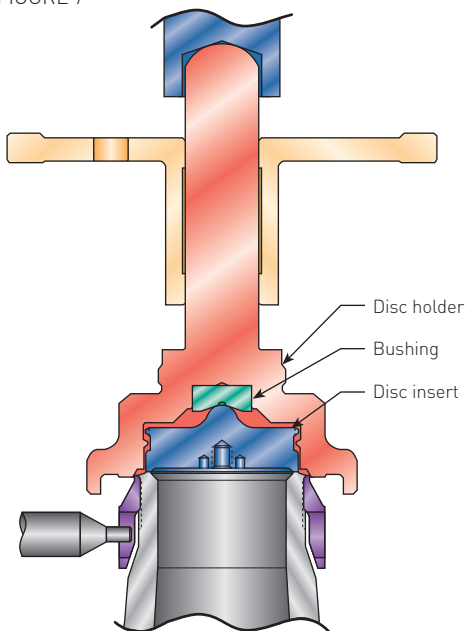

Steam service trim for set pressures greater than 450 psi

FIGURE 8

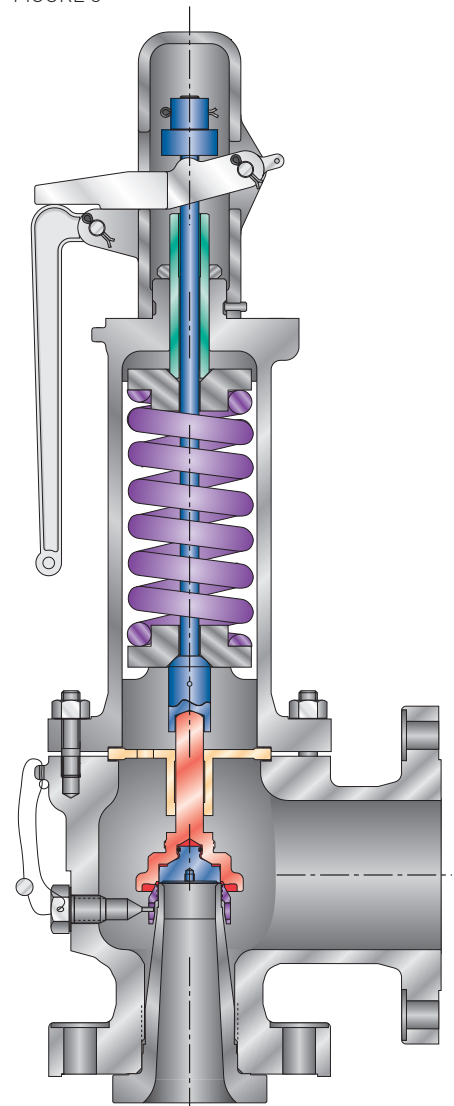

JOS-H-E conventional open bonnet

# CROSBY J-SERIES

## DIRECT SPRING PRESSURE RELIEF VALVES

### SERIES JOS-E AND JLTJOS-E PRESSURE RELIEF VALVES FOR SOUR GAS SERVICE PER NACE MR0175 (2002 EDITION)<sup>[1]</sup>

Level 1 - For applications where compliance with NACE MR0175 is required for wetted parts in the primary (upstream) pressure zone of the pressure relief valve. Materials of construction for Level 1 are standard and can be found on page 6.

Level 2 - For applications where compliance with NACE MR0175 is required for wetted parts in the primary (upstream) and secondary (downstream) pressure zones of the pressure relief valve (Designated as 'N2' in model number).

While the materials recommended for the Series JOS-E and JLTJOS-E sour gas valves are suitable for average service conditions, optional materials are available to provide additional resistance to corrosion beyond the minimum requirements of the standard.

### SERIES JOS-E AND JLTJOS-E MATERIALS OF CONSTRUCTION

No.	Part name	Standard NACE material Level 2 (N2)
1	Body	ASME SA216 Gr. WCB/WCC
2	Nozzle	316 SS
3	Nozzle ring	316 SS
4	Set screw	316 SS
5	Disc holder	316L SS
8	Disc insert	316 SS
9	Retention clip	Inconel® X750
15	Guide	ASTM A297 Gr. HE SST
16	Spindle	316 SS*
17	Spindle cotter pin	SS
18	Spring	Inconel® X750*
19	Spring washer	316 SS*
20	Bonnet	ASME SA216 Gr. WCB/WCC
21	Bonnet stud	Alloy Steel <sup>[2]</sup>
22	Bonnet stud nut	Alloy Steel <sup>[2]</sup>
24	Adjusting bolt	316 SS*
25	Adjusting bolt nut	316 SS
27	Set screw gasket	316 SS
28	Guide gasket	316 SS
30	Pipe plug (bonnet)	CS
34	Seal and wire	Lead and SS
35	Seal clip (not shown)	SS
40	Threaded cap	CS
41	Cap gasket	316 SS

\* Variation from standard and NACE Level 1 product.

### NOTES

- Contact your sales representative for compliance to NACE MR0175 (2003 edition) or NACE MR0175/ISO 15156 requirements.
- If the valve bolting could be directly exposed or in contact with the hydrogen sulfide environment, bonnet studs can be ASME A193 Gr. B7M HRC-22 maximum and bonnet stud nuts can be ASME A194 Class 2HM HRC-22 maximum.

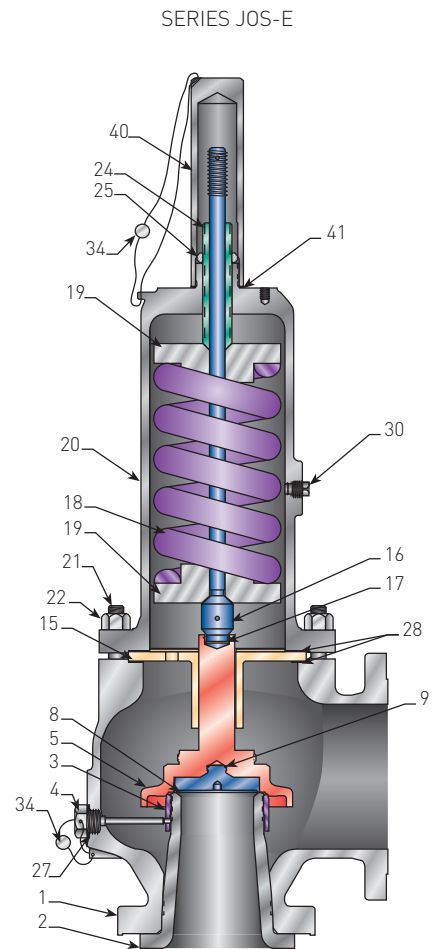

# CROSBY J-SERIES

## DIRECT SPRING PRESSURE RELIEF VALVES

### SERIES JBS-E AND JLTJBS-E PRESSURE RELIEF VALVES FOR SOUR GAS SERVICE PER NACE MR0175 (2002 EDITION)<sup>[1]</sup>

Level 1 - For applications where compliance with NACE MR0175 is required for wetted parts in the primary (upstream) pressure zone of the pressure relief valve. Materials of construction for Level 1 are standard and can be found on page 9.

Level 2 - For applications where compliance with NACE MR0175 is required for wetted parts in the primary (upstream) and secondary (downstream) pressure zones of the pressure relief valve. The Inconel® 625 bellows isolates the valve spring and other critical components above it from the process fluid (Designated as 'N2' in model number).

While the materials recommended for the Series JBS-E and JLTJBS-E sour gas valves are suitable for average service conditions, optional materials are available to provide additional resistance to corrosion beyond the minimum requirements of the standard.

### SERIES JBS-E AND JLTJBS-E MATERIALS OF CONSTRUCTION

No.	Part name	Standard NACE material Level 2 (N2)
1	Body	ASME SA216 Gr. WCB/WCC
2	Nozzle	316 SS
3	Nozzle ring	316 SS
4	Set screw	316 SS
6C	Bellows flange <sup>[2]</sup>	Inconel® 625
6B	Bellows <sup>[2]</sup>	Inconel® 625
6A	Bellows tailpiece <sup>[2]</sup>	316L SS
5	Disc holder	316L SS
8	Disc insert	316 SS
9	Retention clip	Inconel® X750
15	Guide	ASTM A297 Gr. HE SST
16	Spindle	416 SS
17	Spindle cotter pin	SS
18	Spring	Chrome steel-aluminum metallized*
19	Spring washer	Steel
20	Bonnet	ASME SA216 Gr. WCB/WCC
21	Bonnet stud	Alloy steel <sup>[3]</sup>
22	Bonnet stud nut	Steel3
24	Adjusting bolt	316 SS
25	Adjusting bolt nut	316 SS
27	Set screw gasket	316 SS
28	Guide gasket	316 SS
29	Tailpiece gasket	316 SS
34	Seal and wire	Lead and SS
35	Seal clip (not shown)	SS
40	Threaded cap	CS
41	Cap gasket	316 SS

\* Variation from standard product; Crosby may upgrade to Inconel® X750.

#### NOTES

- Contact your sales representative for compliance to NACE MR0175 (2003 edition) or NACE MR0175/ISO 15156 requirements.
- Subassembly.
- If the valve bolting could be exposed directly to or in contact with the hydrogen sulfide environment, bonnet studs can be ASME A193 Gr. B7M HRC-22 maximum and bonnet stud nuts can be ASME A194 Class 2HM HRC-22 maximum.

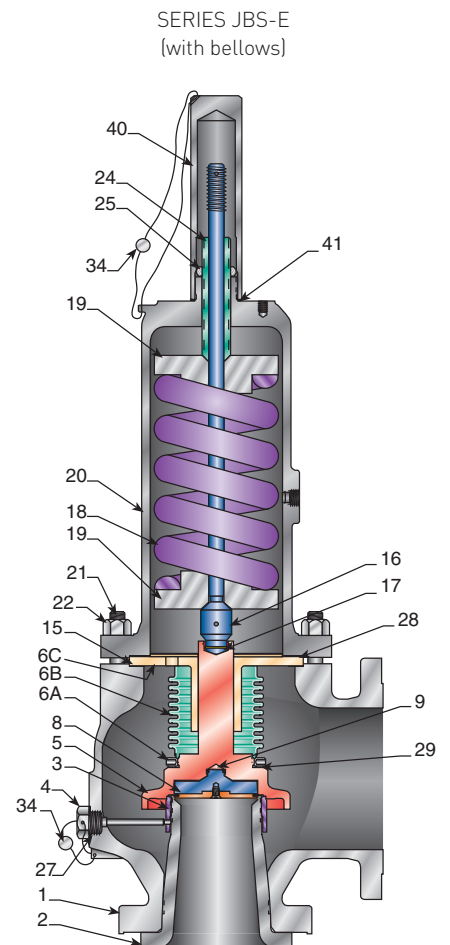

# CROSBY J-SERIES

## DIRECT SPRING PRESSURE RELIEF VALVES

### SERIES JBSBP-E AND JLTJBSBP-E BALANCED BELLOWS VALVES WITH SUPPLEMENTARY BACK PRESSURE BALANCING PISTON

Series JBSBP-E and JLTJBSBP-E are a modification to the standard bellows pressure relief valves which have been designed and tested in collaboration with engineers of one of the world's leading petroleum companies. This adaptation provides additional assurance of safe performance in the event of bellows failure on installations with discharge manifold systems where constant or variable back pressures are present.

With the standard bellows pressure relief valve, if the bellows is broken or ruptured, the valve will perform in the manner of a standard valve without bellows. Introduction of the supplementary back pressure balancing piston assures full performance characteristics of the valve until necessary replacement of the bellows can be made, affording double protection.

Unless compensated for, the effects of back pressure may cause (1) a change in the opening pressure (2) a decrease in valve capacity and (3) valve performance to become unstable at higher back pressure.

Use of the bellows valve with supplementary balancing piston maintains the balancing effect even after bellows failure enabling the valve to function in essentially the same manner as with the bellows intact. However, the bonnet of the valve must be vented to ensure proper valve functioning. The vent also serves as a 'tell-tale' in case of a ruptured or broken bellows.

#### Design

The auxiliary balancing piston is incorporated in the basic bellows valve, modified to include the piston (5B) and the cylinder (17) which is part of the disc holder.

The guiding clearances are held to a minimum and, in addition, grooves in the piston form a labyrinth seal to reduce flow between the piston and cylinder. In the event of a bellows failure, the leakage of fluid to atmosphere is kept to a minimum.

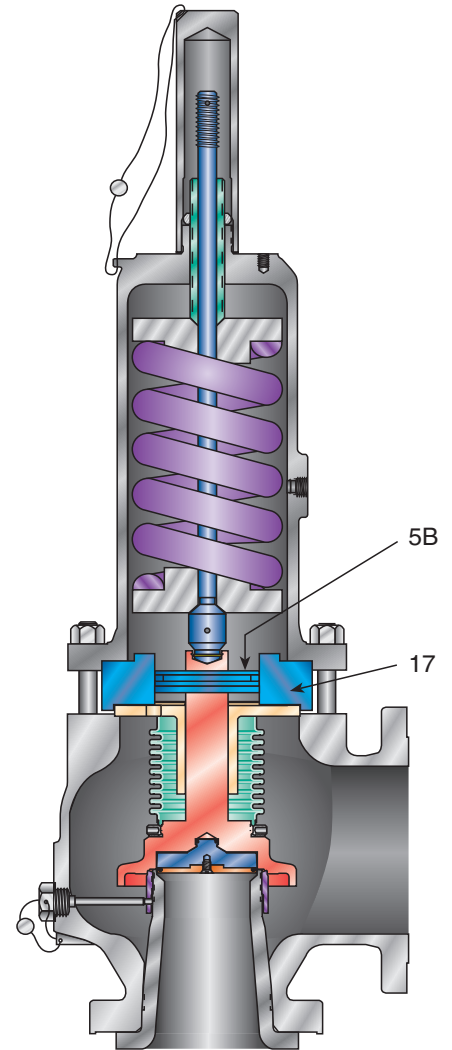

**O-RING SOFT SEAT MATERIALS AND PRESSURE/TEMPERATURE LIMITS**

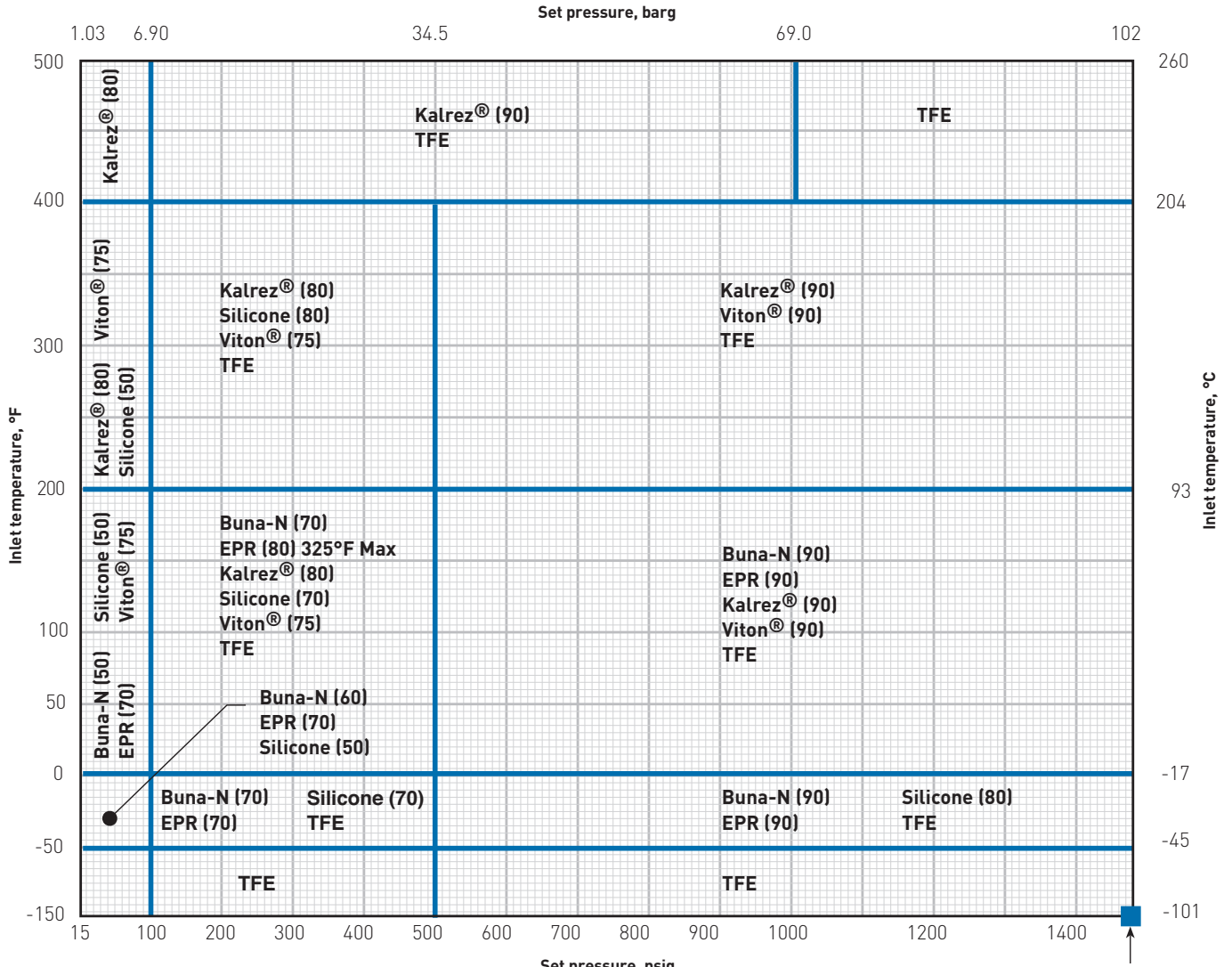

Figures in ( ) are durometer hardness specifications

1480 or max. set pressure rating of the O-ring soft seat valve

**MAXIMUM SET PRESSURE LIMITS**

Orifice	Maximum set pressure	
	psig	barg
D	1480	102.0
E	1480	102.0
F	1480	102.0
G	1480	102.0
H	1480	102.0
J	1480	102.0
K	1480	102.0
L	1000	68.9
M	1100	75.8
N	1000	68.9
P	1000	68.9
Q	600	41.3
R	300	20.6
T	300	20.6
T2	300	20.6

**NOTES**

- Other soft seat materials are available on request. For O-ring seats below -150°F (-101°C) consult your sales representative. For steam service, metal-to-metal seats are recommended; consult your sales representative if soft seats are required. Minimum cold differential test pressure for TFE seat is 100 psig.
- Viton® is a registered trademark of DuPont Performance Elastomers L.L.C.

**EPR** Ethylene Propylene Rubber  
**TFE** Tetrafluoroethylene



# CROSBY J-SERIES

## DIRECT SPRING PRESSURE RELIEF VALVES

### JOS-E, JBS-E AND JLT - VARIATIONS FROM STANDARD MATERIALS

No.	Part name	Low temperature				316 Stainless steel		
		JOS-E/JBS-E/JLT -55°F to 650°F (-48.5°C to 343°C)		JOS-E/JBS-E/JLT( )4 -55°F to 650°F (-48.5°C to 343°C)	JOS-E/JBS-E/JLT( )2 -450°F to -76°F (-268°C to -60°C)	( ) ( ) S4	JOS-E/JBS-E/JLT -50°F to 1000°F (45.6°C to 538°C)	( ) ( ) S6
1	Body	ASME SA352 Gr. LCB/LCC	ASME SA352 Gr. LCB/LCC	ASME SA351 Gr. CF8M	ASME SA351 Gr. CF8M	ASME SA216 Gr. WCB/WCC	ASME SA351 Gr. CF8M	ASME SA351 Gr. CF8M
2	Nozzle	316 SS	316 SS	316 SS	316 SS	316 SS	316 SS	316 SS
3	Nozzle ring	316 SS	316 SS	316 SS	316 SS	316 SS	316 SS	316 SS
4	Set screw	316 SS	316 SS	316 SS	316 SS	316 SS	316 SS	316 SS
5	Disc holder	316L SS	316L SS	316L SS	316L SS	316L SS	316L SS	316L SS
6C	Bellows flange <sup>(1)</sup>	Inconel <sup>®</sup> 625	Inconel <sup>®</sup> 625	Inconel <sup>®</sup> 625	Inconel <sup>®</sup> 625	Inconel <sup>®</sup> 625	Inconel <sup>®</sup> 625	Inconel <sup>®</sup> 625
6B	Bellows <sup>(1)</sup>	Inconel <sup>®</sup> 625	Inconel <sup>®</sup> 625	Inconel <sup>®</sup> 625	Inconel <sup>®</sup> 625	Inconel <sup>®</sup> 625	Inconel <sup>®</sup> 625	Inconel <sup>®</sup> 625
6A	Bellows tailpiece <sup>(1)</sup>	316L SS	316L SS	316L SS	316L SS	316L SS	316L SS	316L SS
8	Disc insert <sup>(2)</sup>	316 SS	316 SS	316 SS	316 SS	316 SS	316 SS	316 SS
9	Retention clip <sup>(3)</sup>	Inconel <sup>®</sup> X750	Inconel <sup>®</sup> X750	Inconel <sup>®</sup> X750	Inconel <sup>®</sup> X750	Inconel <sup>®</sup> X750	Inconel <sup>®</sup> X750	Inconel <sup>®</sup> X750
10	O-ring	Specify	Specify	Specify	Specify	Specify	Specify	Specify
11	O-ring retainer	316 SS	316 SS	316 SS	316 SS	316 SS	316 SS	316 SS
12	Retainer screws	18-8 SS	18-8 SS	18-8 SS	18-8 SS	18-8 SS	18-8 SS	18-8 SS
15	Guide	ASTM A297 Gr. HE SST	ASTM A297 Gr. HE SST	ASTM A297 Gr. HE SST	ASTM A297 Gr. HE SST	ASTM A297 Gr. HE SST	ASTM A297 Gr. HE SST	ASTM A297 Gr. HE SST
16	Spindle	416 SS	416 SS	416 SS	316 SS	316 SS	316 SS	316 SS
17	Spindle cotter pin	SS	SS	SS	SS	SS	SS	SS
18	Spring	Chrome steel	Inconel <sup>®</sup> X750	Chrome steel <sup>(4)</sup> or Inconel <sup>®</sup> X750	316 SS	Chrome steel <sup>(4)</sup> or Alloy steel <sup>(5)</sup>	Inconel <sup>®</sup> X750	316 SS
19	Spring washers	CS	316 SS	CS	316 SS	316 SS	316 SS	316 SS
20	Bonnet	ASME SA352 Gr. LCB/LCC	ASME SA352 Gr. LCB/LCC	ASME SA351 Gr. CF8M	ASME SA351 Gr. CF8M	ASME SA216 Gr. WCB/WCC	ASME SA351 Gr. CF8M	ASME SA351 Gr. CF8M
21	Bonnet stud	ASME SA193 Gr. B7	ASME SA193 Gr. B7	ASME SA193 Gr. B8	ASME SA320 Gr. B8	ASME SA193 Gr. B7	ASME SA193 Gr. B8	ASME SA193 Gr. B8
22	Bonnet stud nut	ASME SA194 CL. 2H	ASME SA194 CL. 2H	ASME SA194 Gr. 8	ASME SA194 Gr. 8	ASME SA194 CL. 2H	ASME SA194 Gr. 8	ASME SA194 Gr. 8
24	Adjusting bolt	316 SS	316 SS	316 SS	316 SS	316 SS <sup>(6)</sup>	316 SS	316 SS
25	Adjusting bolt nut	316 SS	316 SS	316 SS	316 SS	316 SS	316 SS	316 SS
26	Nameplate (not shown)	SS	SS	SS	SS	SS	SS	SS
27	Set screw gasket <sup>(2)</sup>	316 SS	316 SS	316 SS	316 SS	316 SS	316 SS	316 SS
28	Guide gasket <sup>(2)</sup>	316 SS	316 SS	316 SS	316 SS	316 SS	316 SS	316 SS
29	Tailpiece gasket <sup>(2)</sup>	316 SS	316 SS	316 SS	316 SS	316 SS	316 SS	316 SS
30	Pipe plug (non-bellows)	CS	CS	316 SS	316 SS	CS	316 SS	316 SS
34	Seal and wire	Lead and SS	Lead and SS	Lead and SS	Lead and SS	Lead and SS	Lead and SS	Lead and SS
35	Seal clip (not shown)	SS	SS	SS	SS	SS	SS	SS
40	Threaded cap	CS	CS	316 SS	316 SS	CS	316 SS	316 SS
41	Cap gasket <sup>(2)</sup>	316 SS	316 SS	316 SS	316 SS	316 SS	316 SS	316 SS

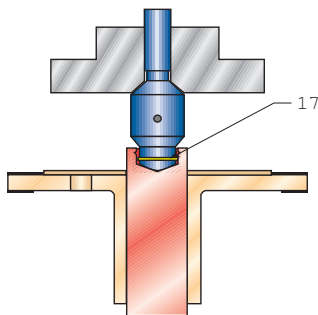

COTTER PINS  
Used in L orifice and above only

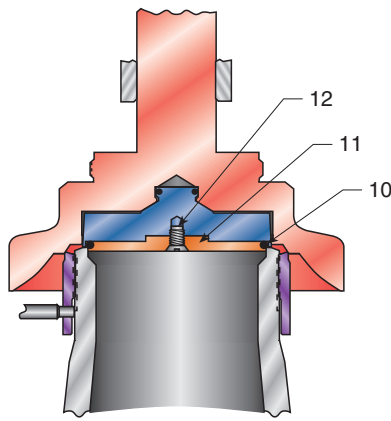

JLT  
O-ring soft seat

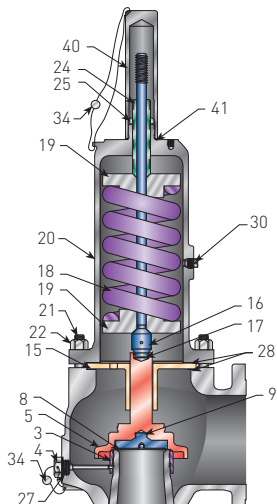

JOS-E

# CROSBY J-SERIES

## DIRECT SPRING PRESSURE RELIEF VALVES

### JOS-E, JBS-E AND JLT - VARIATIONS FROM STANDARD MATERIALS (continued)

No.	Part name	Monel®					Hastelloy®				
		( ) M1	( ) M4	( ) M5	( ) M6	( ) M	( ) H1	( ) H4	( ) H5	( ) H6	( ) H
1	Body	ASME SA216 Gr. WCB/WCC	ASME SA216 Gr. WCB/WCC	ASME SA494 Gr. M35-19	ASME SA494 Gr. M35-1	ASME SA494 Gr. M35-19	ASME SA216 Gr. WCB/WCC	ASME SA216 Gr. WCB/WCC	ASME SA494 Gr. CW-12MW	ASME SA494 Gr. CW-12MW	ASME SA494 Gr. CW-12MW
2	Nozzle	Monel®	Monel®	Monel®	Monel®	Monel®	Hastelloy® C	Hastelloy® C	Hastelloy® C	Hastelloy® C	Hastelloy® C
3	Nozzle ring	316 SS	Monel®	Monel®	Monel®	Monel®	316 SS	Monel®	Hastelloy® C	Hastelloy® C	Hastelloy® C
4	Set screw	316 SS	Monel®	Monel®	Monel®	Monel®	316 SS	Monel®	Hastelloy® C	Hastelloy® C	Hastelloy® C
5	Disc holder	316L SS	Monel®	Monel®	Monel®	Monel®	316L SS	Hastelloy® C	Hastelloy® C	Hastelloy® C	Hastelloy® C
6C	Bellows flange <sup>[1]</sup>	Inconel® 625	Monel®	Monel®	Monel®	Monel®	Inconel® 625	Hastelloy® C	Hastelloy® C	Hastelloy® C	Hastelloy® C
6B	Bellows <sup>[1]</sup>	Inconel® 625	Monel®	Monel®	Monel®	Monel®	Inconel® 625	Hastelloy® C	Hastelloy® C	Hastelloy® C	Hastelloy® C
6A	Bellows tailpiece <sup>[1]</sup>	316L SS	Monel®	Monel®	Monel®	Monel®	316L SS	Hastelloy® C	Hastelloy® C	Hastelloy® C	Hastelloy® C
8	Disc insert <sup>[2]</sup>	Monel®	Monel®	Monel®	Monel®	Monel®	Hastelloy® C	Hastelloy® C	Hastelloy® C	Hastelloy® C	Hastelloy® C
9	Retention clip <sup>[3]</sup>	Inconel® X750	Inconel® X750	Inconel® X750	Inconel® X750	Inconel® X750	Inconel® X750	Inconel® X750	Inconel® X750	Inconel® X750	Inconel® X750
10	O-ring	Specify	Specify	Specify	Specify	Specify	Specify	Specify	Specify	Specify	Specify
11	O-ring retainer	Monel®	Monel®	Monel®	Monel®	Monel®	Hastelloy® C	Hastelloy® C	Hastelloy® C	Hastelloy® C	Hastelloy® C
12	Retainer screws	Monel®	Monel®	Monel®	Monel®	Monel®	Hastelloy® C	Hastelloy® C	Hastelloy® C	Hastelloy® C	Hastelloy® C
15	Guide	ASTM A297 Gr. HE SST	Monel®	Monel®	Monel®	Monel®	ASTM A297 Gr. HE SST	Hastelloy® C	Hastelloy® C	Hastelloy® C	Hastelloy® C
16	Spindle	416 SS	Monel®	Monel®	Monel®	Monel®	416 SS	Monel®	Hastelloy® C	Hastelloy® C	Hastelloy® C
17	Spindle cotter pin	SS	Monel®	Monel®	Monel®	Monel®	SS	Monel®	Hastelloy® C or Monel®	Hastelloy® C	Hastelloy® C or Monel®
18	Spring	Chrome steel <sup>[4]</sup> or Alloy steel <sup>[4]</sup>	Chrome steel <sup>[5]</sup> or Alloy steel <sup>[5]</sup>	Chrome steel <sup>[5]</sup> Nickel plated <sup>[6]</sup>	Inconel® X750	Monel® or Inconel® X750	Chrome steel <sup>[4]</sup> or Alloy steel <sup>[4]</sup>	Chrome steel <sup>[5]</sup> or Alloy steel <sup>[5]</sup>	Chrome steel <sup>[5]</sup> Nickel plated <sup>[6]</sup>	Inconel® X750	Hastelloy® C or Inconel® X750
19	Spring washers	CS	316 SS	316 SS	Monel®	Monel®	CS	316 SS	316 SS	Hastelloy® C	Hastelloy® C
20	Bonnet	ASME SA216 Gr. WCB/WCC	ASME SA216 Gr. WCB/WCC	ASME A494 Gr. M35-19	ASME A494 Gr. M35-1	ASME A494 Gr. M35-19	ASME SA216 Gr. WCB/WCC	ASME SA216 Gr. WCB/WCC	ASME A494 Gr. CW-12MW	ASME A494 Gr. CW-12MW	ASME A494 Gr. CW-12MW
21	Bonnet stud	ASME SA193 Gr. B7	ASME SA193 Gr. B7	ASME SA193 Gr. B8	ASME SA193 Gr. B8	ASME SA193 Gr. B8	ASME SA193 Gr. B7	ASME SA193 Gr. B7	Hastelloy® C	Hastelloy® C	Hastelloy® C
22	Bonnet stud nut	ASME SA194 CL. 2H	ASME SA194 CL. 2H	ASME SA194 Gr. 8	ASME SA194 Gr. 8	ASME SA194 Gr. 8	ASME SA194 CL. 2H	ASME SA194 CL. 2H	Hastelloy® C	Hastelloy® C	Hastelloy® C
24	Adjusting bolt	316 SS <sup>[4]</sup>	Monel®	Monel®	Monel®	Monel®	316 SS <sup>[4]</sup>	Monel®	Hastelloy® C	Hastelloy® C	Hastelloy® C
25	Adjusting bolt nut	316 SS	Monel®	Monel®	Monel®	Monel®	316 SS	Monel®	Hastelloy® C	Hastelloy® C	Hastelloy® C
26	Nameplate (not shown)	SS	SS	SS	SS	SS	SS	SS	SS	SS	SS
27	Set screw gasket <sup>[2]</sup>	316 SS	Monel®	Monel®	Monel®	Monel®	316 SS	Monel®	Monel®	Monel®	Monel®
28	Guide gasket <sup>[2]</sup>	316 SS	Monel®	Monel®	Monel®	Monel®	316 SS	Monel®	Monel®	Monel®	Monel®
29	Tailpiece gasket <sup>[2]</sup>	316 SS	Monel®	Monel®	Monel®	Monel®	316 SS	Monel®	Monel®	Monel®	Monel®
30	Pipe plug (non-bellows)	CS	CS	Monel®	Monel®	Monel®	CS	CS	Hastelloy® C	Hastelloy® C	Hastelloy® C
34	Seal and wire	Lead and SS	Lead and SS	Lead and SS	Lead and SS	Lead and SS	Lead and SS	Lead and SS	Lead and SS	Lead and SS	Lead and SS
35	Seal clip (not shown)	SS	SS	SS	SS	SS	SS	SS	SS	SS	SS
40	Threaded cap	CS	CS	Monel®	Monel®	Monel®	CS	CS	Hastelloy® C	Hastelloy® C	Hastelloy® C
41	Cap gasket <sup>[2]</sup>	316 SS	Monel®	Monel®	Monel®	Monel®	316 SS	Monel®	Monel®	Monel®	Monel®

#### NOTES

- Subassembly.
- Recommended spare part.
- Furnished with disc insert.
- Corrosion resistant coating.
- Crosby may upgrade to Inconel® X750.
- Class 900#, 1500#, and 2500# inlet ratings use 416 SS.
- Temperature limit for 316 SS spring is +500°F [+260°C].
- For temperatures above +650°F [+343°C], Crosby will supply either alloy steel nickel plated or Inconel® X750.
- Permitted by ASME Code Case 1750.
- Minimum temperature for Inconel® X750 springs is -320°F [-196°C]

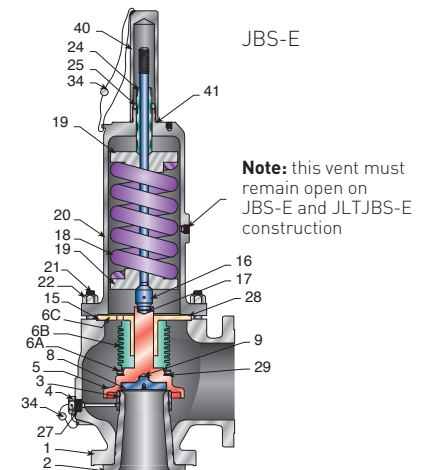

**CROSBY J-SERIES**  
 DIRECT SPRING PRESSURE RELIEF VALVES

**CAPS AND LIFTING LEVERS**

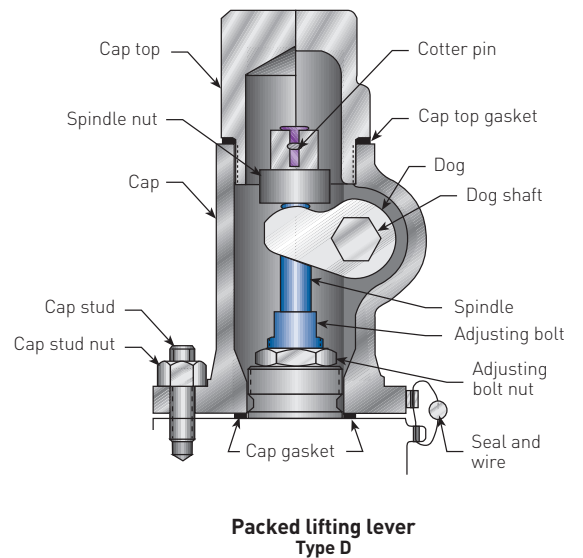
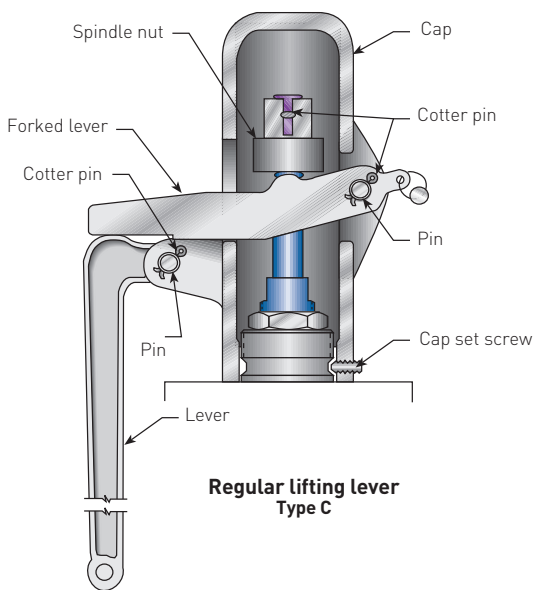
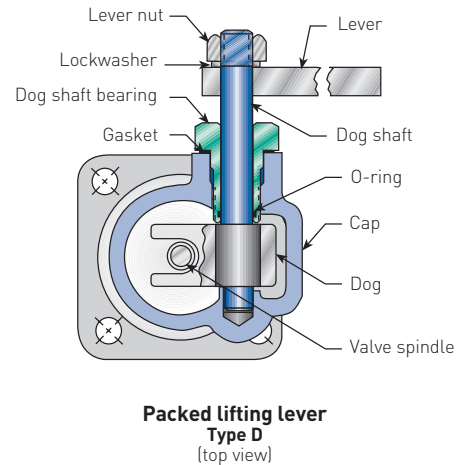
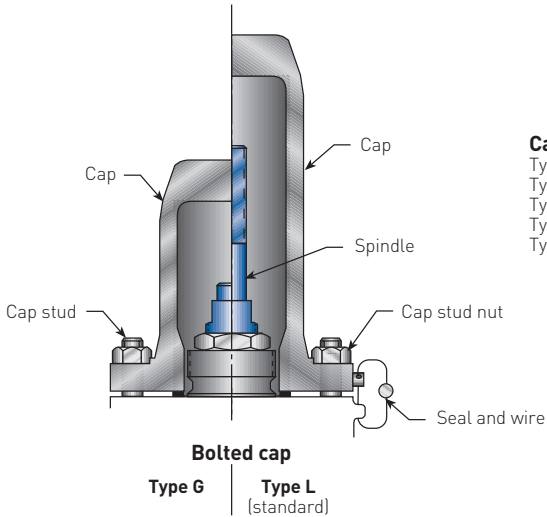
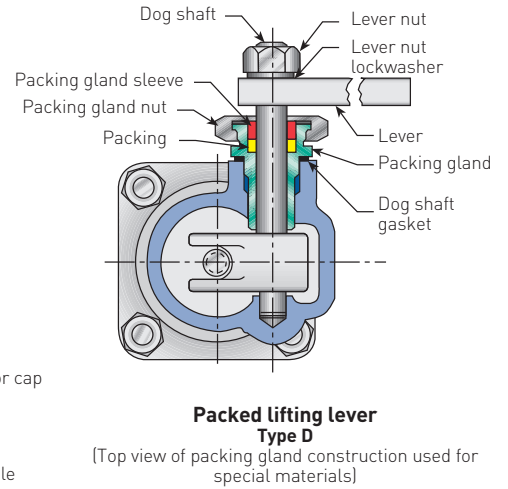
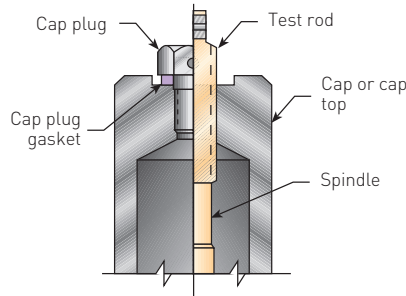
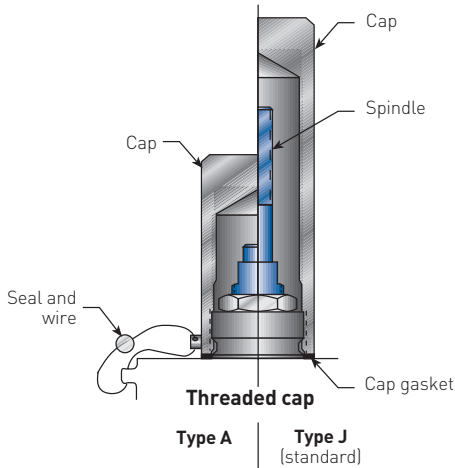

# CROSBY J-SERIES

## DIRECT SPRING PRESSURE RELIEF VALVES

---

### CAPS AND LIFTING LEVERS

---

#### Caps

Styles JOS-E/JBS-E/JLT pressure relief valves are furnished with a closed bonnet and screwed cap over the adjusting bolt. The following types of top construction are available, except where indicated otherwise:

Screwed cap (Type J standard) - where no lifting lever is required.

Bolted cap (Type L) - where no lifting lever is required. Available to special order.

#### Lifting levers

ASME Code Section VIII requires that a lifting lever must be supplied with the valve when the service is: (1) air (2) water at the valve inlet that exceeds 140°F (60°C), excluding overpressure or relief events or (3) steam.

Regular (Type C) - for steam and air service where the valve cap is not required to be tight on the discharge side and where conditions dictate a requirement for periodic testing. Regular lifting levers may be furnished with a supplementary gagging device on special order (designated as Type T).

Packed (Type D) - For services where tightness on the discharge side is necessary and where conditions dictate a requirement for periodic testing. Also recommended for hot water services.

ASME Code Section VIII requirements for lifting levers: The omission of the lifting lever is permitted under Code Case 2203. However, Pentair Valves & Controls requires that orders for relief valves intended for steam, air or water over 140°F without lifting levers must indicate that the valves are specified in accordance with Code Case 2203. The buyer is responsible for obtaining jurisdictional approval for use of this Code Case.

#### Test rods

Types K, E or M - valves with screwed caps, packed lifting levers or bolted caps can be fitted to accommodate test rods which will hold the valve closed when the equipment on which they are installed is hydrostatically tested.

Type J screwed cap changes to Type K with test rod. Type D packed lifting lever changes to Type E with test rod.

Type L bolted cap changes to Type M with test rod.

#### Height restricted applications

For applications where there are height restrictions, cap Types A, B, G and H are available.

#### CAUTION

*Test rods should never be tightened more than finger-tight as over-tightening may damage internal parts. Also, a test rod should never be kept on the valve during operation of the equipment. During normal operation the test rod is replaced with a cap plug and gasket to maintain tightness on the discharge side.*

**CROSBY J-SERIES**  
DIRECT SPRING PRESSURE RELIEF VALVES

**CAP AND LEVER MATERIALS**

Part name	Standard material			Variations from standard materials				
	JOS/JBS-( )5,6,7 -20°F to 1000°F [-29°C to 538°C]	JOS/JBS-( )14 -75°F to -21°F [-59°C to -30°C]	JOS/JBS-( )12 -450°F to -76°F [-268°C to -60°C]	( ) )S, S6	( ) )S4	( ) )M and ( ) )M5 <sup>(1)</sup> , M6	( ) )M4 and ( ) )H4 <sup>(1)</sup>	( ) )H and ( ) )H5 <sup>(1)</sup> , H6
Cap (J, K, D, E, L, M)	CS	316 SS	316 SS	316 SS	CS	Monel®	CS	Hastelloy® C
Cap (C)	Iron/steel	Iron/steel	316 SS	316 SS	Iron/steel	<sup>(3)</sup>	<sup>(3)</sup>	<sup>(3)</sup>
Cap top (D, E)	Steel	316 SS	316 SS	316 SS	Steel	Monel®	Steel	Hastelloy® C
Cap set screw (C)	SS	SS	SS	SS	SS	<sup>(3)</sup>	<sup>(3)</sup>	<sup>(3)</sup>
Cap stud	Alloy steel	304 SS	304 SS	304 SS	Alloy steel	304 SS	Alloy steel	Hastelloy® C
Cap stud nut	Steel	304 SS	304 SS	304 SS	Steel	304 SS	Steel	Hastelloy® C
Lever (D, E)	Steel	Steel	316 SS	316 SS	Steel	316 SS	Steel	316 SS
Lever (C)	Malleable iron	Malleable iron	316 SS	316 SS	Malleable iron	<sup>(3)</sup>	<sup>(3)</sup>	<sup>(3)</sup>
Forked lever (C)	Malleable iron	Malleable iron	316 SS	316 SS	Malleable iron	<sup>(3)</sup>	<sup>(3)</sup>	<sup>(3)</sup>
Pin (lever, forked lever)	Steel	Steel	SS	SS	Steel	<sup>(3)</sup>	<sup>(3)</sup>	<sup>(3)</sup>
Cotter Pins	Steel	Steel	SS	SS	Steel	SS	Steel	SS
Lever nut (D, E)	Steel	Steel	316 SS	316 SS	316 SS	SS	316 SS	316 SS
Lever nut lockwasher	Steel	Steel	SS	SS	Steel	SS	Steel	SS
Spindle nut	Steel	Steel	316 SS	316 SS	316 SS	Monel®	Monel®	Hastelloy® C
Dog	Steel	Steel	316 SS	316 SS	316 SS	Monel®	Monel®	Hastelloy® C
Dog shaft	416 SS	416 SS	316 SS	316 SS	316 SS	Monel®	Monel®	Hastelloy® C
Dog shaftbearing	416 SS	416 SS	<sup>(2)</sup>	<sup>(2)</sup>	<sup>(2)</sup>	<sup>(2)</sup>	<sup>(2)</sup>	<sup>(2)</sup>
Dog shaft bearing O-ring	FKM	FKM	<sup>(2)</sup>	<sup>(2)</sup>	<sup>(2)</sup>	<sup>(2)</sup>	<sup>(2)</sup>	<sup>(2)</sup>
Packing gland	<sup>(2)</sup>	<sup>(2)</sup>	316 SS	316 SS	316 SS	Monel®	Monel®	Monel®
Packing gland sleeve	<sup>(2)</sup>	<sup>(2)</sup>	316 SS	316 SS	416 SS	Monel®	416 SS	Monel®
Packing gland nut	<sup>(2)</sup>	<sup>(2)</sup>	316 SS	316 SS	Steel	Monel®	Steel	Monel®
Packing	<sup>(2)</sup>	<sup>(2)</sup>	PTFE	PTFE	PTFE	PTFE	PTFE	PTFE
Test rod (K, E, M)	416 SS	416 SS	416 SS	416 SS	416 SS	416 SS	416 SS	416 SS
Cap plug (K, E, M)	416 SS	416 SS	316 SS	316 SS	416 SS	Monel®	416 SS	Hastelloy® C
Gaskets	316SS	316SS	316SS	316SS	316SS	Monel®	Monel®	Monel®

**NOTES**

1. Special material valves ( ) )M1 and ( ) )H1 use caps and lifting gear of standard materials.
2. Packing gland construction is standard for special material valves.
3. Type C cap not available in M4, M5, M6, M, H4, H5, H6 or H material options.

# CROSBY J-SERIES

## DIRECT SPRING PRESSURE RELIEF VALVES

### SIZES AND PRESSURE/TEMPERATURE LIMITS

#### D ORIFICE, 0.110 sq.in. (71 sq.mm) API EFFECTIVE AREA

Valve series	Valve size		Standard connections		Maximum set pressure psig (barg)					Back press. limit at 100°F psig (38°C barg)		
	Inlet X	Orifice X	ANSI flanges raised face		Inlet					JOS <sup>[2]</sup>	JBS <sup>[2]</sup>	
			Inlet	Outlet	-450°F to -76°F (-268°C to -60°C)	-75°F to -21°F (-59°C to -30°C)	-20°F to +100°F (-29°C to +38°C)	+650°F <sup>[1]</sup> (+343°C <sup>[1]</sup> )	+800°F (+427°C)			+1000°F (+538°C)
JOS-E-	15	1D2	150	150			285 (19.6)	125 (8.62)			285 (19.6)	230 (15.8)
JBS-E-	25	1D2	300	150			285 (19.6)	285 (19.6)			285 (19.6)	230 (15.8)
JLT-	35	1D2	300	150			740 (51.0)	535 (36.8)			285 (19.6)	230 (15.8)
JOS-H-E- <sup>[1]</sup>	45	1D2	600	150			1480 (102)	1075 (74.1)			285 (19.6)	230 (15.8)
JOS-E-	55	1½ D2	900	300			2220 (153)	1650 (111)			600 (41.3)	600 (41.3)
JBS-E-	65	1½ D2	1500	300			3705 (255)	2745 (185)			600 (41.3)	600 (41.3)
JLT-	75	1½ D3 <sup>[5]</sup>	2500	300			6000 (413)	4475 (308)			740 (51.0)	600 (41.3)
JOS-E-	16	1D2	150	150				125 (8.62)	80 (5.51)		285 (19.6)	230 (15.8)
JBS-E-	26	1D2	300	150				285 (19.6)	285 (19.6)		285 (19.6)	230 (15.8)
JLT-	36	1D2	300	150				535 (36.8)	410 (28.2)		285 (19.6)	230 (15.8)
	46	1D2	600	150				1075 (74.1)	825 (56.8)		285 (19.6)	230 (15.8)
JOS-E-	56	1½ D2	900	300				1650 (111)	1235 (85.1)		600 (41.3)	600 (41.3)
JBS-E-	66	1½ D2	1500	300				2745 (185)	2060 (142)		600 (41.3)	600 (41.3)
JLT-	76	1½ D3 <sup>[5]</sup>	2500	300				4475 (308)	3430 (236)		740 (51.0)	600 (41.3)
JOS-E-	37	1D2	300	150					510 (35.1)	215 (14.8)	285 (19.6)	230 (15.8)
JBS-E-	47	1D2	600	150					1015 (70)	430 (29.6)	285 (19.6)	230 (15.8)
JLT-												
JOS-E-	57	1½ D2	900	300					1525 (105)	650 (44.8)	600 (41.3)	600 (41.3)
JBS-E-	67	1½ D2	1500	300					2540 (175)	1080 (74.4)	600 (41.3)	600 (41.3)
JLT-	77	1½ D3 <sup>[5]</sup>	2500	300					4230 (291)	1800 (124)	740 (51.0)	600 (41.3)
JOS-E-	14	1D2	150	150		275 (18.9)					275 (18.9)	230 (15.8)
JBS-E-	24	1D2	300	150		275 (18.9)					275 (18.9)	230 (15.8)
JLT-	34	1D2	300	150		720 (49.6)					275 (18.9)	230 (15.8)
	44	1D2	600	150		1440 (99.3)					275 (18.9)	230 (15.8)
JOS-E-	12	1D2	150	150	275 (18.9)						275 (18.9)	230 (15.8)
JBS-E-	22	1D2	300	150	275 (18.9)						275 (18.9)	230 (15.8)
JLT-	32	1D2	300	150	720 (49.6)						275 (18.9)	230 (15.8)
	42	1D2	600	150	1440 (99.3)						275 (18.9)	230 (15.8)

#### NOTES

- Upper temperature limit of JOS-H-E-15, 25, 35 and 45 valves is +800°F (+427°C).
- Outlet pressure for temperatures above +100°F (+38°C) should not exceed the ANSI flange rating.
- Valves set below 15 psig (1.03 barg) cannot be stamped with the ASME Code Symbol. Only metal seated valves may be set below 15 psig.
- Series designations: JLTJOS-E and JLTJBS-E signify Series JOS-E, JBS-E with liquid trim for liquid and gas service.
- Optional 2½" outlet available. Contact the factory for dimensions.

#### LOW SET PRESSURE LIMITS

JOS-E	10 psig (0.68 barg)
JBS-E	15 psig (1.72 barg)
JLTJOS-E	15 psig (1.03 barg)
JLTJBS-E	25 psig (1.72 barg)

#### DIMENSIONS AND WEIGHTS

Valve series	Valve dimensions, inches (mm)						Approx. weight lbs (kg)	
	Center to face		Use to find bolt length	Approximate height				
	Inlet	Outlet		Valve (cap) type				
	E	F	X	A and G	J and L	C	D	J
<b>JOS-E-, JBS-E-, JLT-, JOS-H-E-</b>								
12, 14, 15, 16, 22, 24, 25, 26	4⅞ (105)	4½ (114)	1⅞ (40)	16¾ (426)	19¾ (502)	19 (483)	19½ (495)	36 (16)
32, 34, 35, 36, 37	4⅞ (105)	4½ (114)	1⅞ (40)	16¾ (426)	19¾ (502)	19 (483)	19½ (495)	36 (16)
42, 44, 45, 46, 47	4⅞ (105)	4½ (114)	1⅞ (40)	16¾ (426)	19¾ (502)	19 (483)	19½ (495)	36 (16)
<b>JOS-E-, JBS-E-, JLT-</b>								
55, 56, 57, 65, 66, 67	4⅞ (105)	5½ (140)	2 (51)	17½ (445)	20½ (521)	19¾ (502)	20¼ (514)	65 (29)
75, 76, 77 <sup>[5]</sup>	5½ (140)	7 (178)	2½ (64)	18¾ (477)	21¾ (552)	21 (533)	21½ (546)	75 (34)

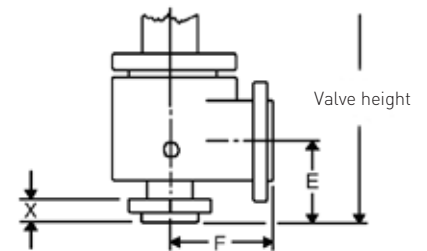

- Type J (Threaded Cap)
- Type C (Regular Lifting Lever) Also JOS-H-E
- Type D (Packed Lifting Lever)
- Type L (Bolted Cap)

**CROSBY J-SERIES**  
 DIRECT SPRING PRESSURE RELIEF VALVES

PRESSURE/TEMPERATURE LIMIT CHART - TO ANSI CLASS 600  
 D Orifice, 0.110 sq.in. [71 sq.mm] API effective area

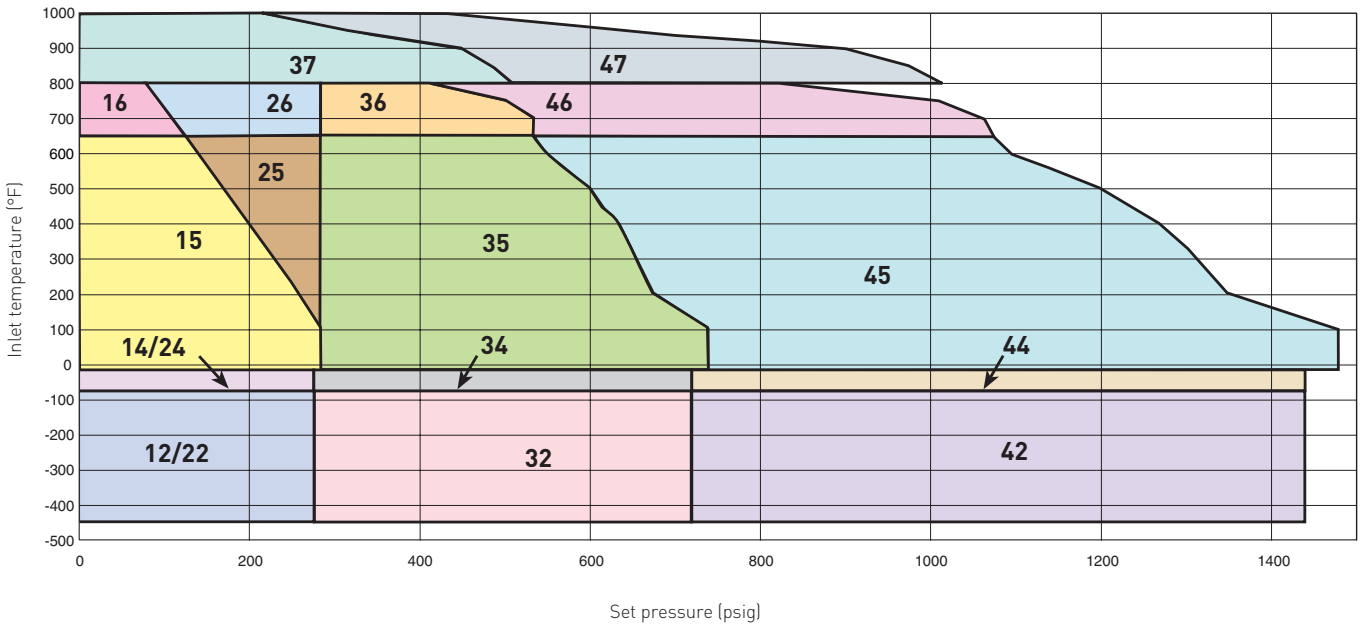

PRESSURE/TEMPERATURE LIMIT CHART - ANSI CLASS 900, CLASS 1500, CLASS 2500  
 D Orifice, 0.110 sq.in. [71 sq.mm] API effective area

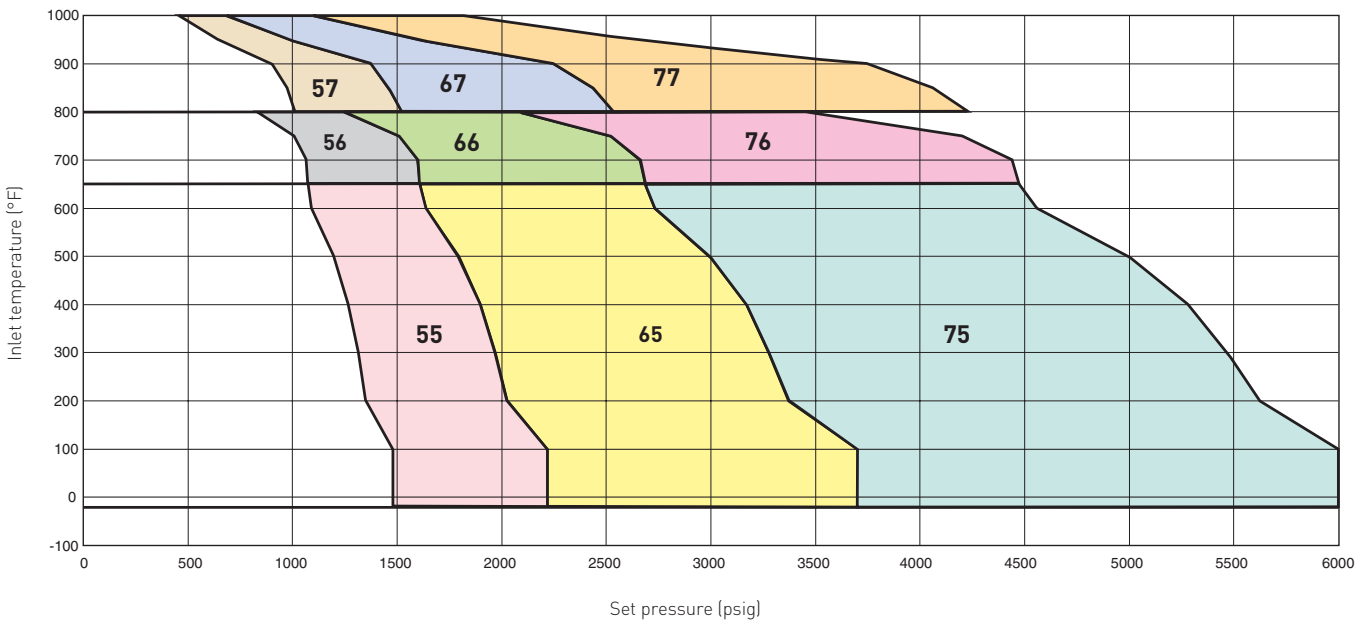

# CROSBY J-SERIES

## DIRECT SPRING PRESSURE RELIEF VALVES

### SIZES AND PRESSURE/TEMPERATURE LIMITS

#### E ORIFICE, 0.196 sq.in. (126 sq.mm) API EFFECTIVE AREA

Valve series	Valve size		Standard connections ANSI		Maximum set pressure psig (barg)						Back press. limit at 100°F psig (38°C barg)	
	Inlet X	Orifice X Outlet	flanges raised face		Inlet						JOS <sup>[2]</sup>	JBS <sup>[2]</sup>
			Inlet	Outlet	-450°F to -76°F [-268°C to -60°C]	-75°F to -21°F [-59°C to -30°C]	-20°F to +100°F [-29°C to +38°C]	+650°F <sup>[1]</sup> [+343°C <sup>[1]</sup> ]	+800°F [+427°C]	+1000°F [+538°C]		
JOS-E-	15	1E2	150	150			285 [19.6]	125 [8.62]			285 [19.6]	230 [15.8]
JBS-E-	25	1E2	300	150			285 [19.6]	285 [19.6]			285 [19.6]	230 [15.8]
JLT-	35	1E2	300	150			740 [51.0]	535 [36.8]			285 [19.6]	230 [15.8]
JOS-H-E- <sup>[1]</sup>	45	1E2	600	150			1480 [102]	1075 [74.1]			285 [19.6]	230 [15.8]
JOS-E-	55	1½ E2	900	300			2220 [153]	1650 [111]			600 [41.3]	600 [41.3]
JBS-E-	65	1½ E2	1500	300			3705 [255]	2745 [185]			600 [41.3]	600 [41.3]
JLT-	75	1½ E3 <sup>[5]</sup>	2500	300			6000 [413]	4475 [308]			740 [51.0]	600 [41.3]
JOS-E-	16	1E2	150	150				125 [8.62]	80 [5.51]		285 [19.6]	230 [15.8]
JBS-E-	26	1E2	300	150				285 [19.6]	285 [19.6]		285 [19.6]	230 [15.8]
JLT-	36	1E2	300	150				535 [36.8]	410 [28.2]		285 [19.6]	230 [15.8]
	46	1E2	600	150				1075 [74.1]	825 [56.8]		285 [19.6]	230 [15.8]
JOS-E-	56	1½ E2	900	300				1650 [111]	1235 [85.1]		600 [41.3]	600 [41.3]
JBS-E-	66	1½ E2	1500	300				2745 [185]	2060 [142]		600 [41.3]	600 [41.3]
JLT-	76	1½ E3 <sup>[5]</sup>	2500	300				4475 [308]	3430 [236]		740 [51.0]	600 [41.3]
JOS-E-	37	1E2	300	150					510 [35.1]	215 [14.8]	285 [19.6]	230 [15.8]
JBS-E-	47	1E2	600	150					1015 [70]	430 [29.6]	285 [19.6]	230 [15.8]
JLT-												
JOS-E-	57	1½ E2	900	300					1525 [105]	650 [44.8]	600 [41.3]	600 [41.3]
JBS-E-	67	1½ E2	1500	300					2540 [175]	1080 [74.4]	600 [41.3]	600 [41.3]
JLT-	77	1½ E3 <sup>[5]</sup>	2500	300					4230 [291]	1800 [124]	740 [51.0]	600 [41.3]
JOS-E-	14	1E2	150	150		275 [18.9]					275 [18.9]	230 [15.8]
JBS-E-	24	1E2	300	150		275 [18.9]					275 [18.9]	230 [15.8]
JLT-	34	1E2	300	150		720 [49.6]					275 [18.9]	230 [15.8]
	44	1E2	600	150		1440 [99.3]					275 [18.9]	230 [15.8]
JOS-E-	12	1E2	150	150	275 [18.9]						275 [18.9]	230 [15.8]
JBS-E-	22	1E2	300	150	275 [18.9]						275 [18.9]	230 [15.8]
JLT-	32	1E2	300	150	720 [49.6]						275 [18.9]	230 [15.8]
	42	1E2	600	150	1440 [99.3]						275 [18.9]	230 [15.8]

#### NOTES

- Upper temperature limit of JOS-H-E-15, 25, 35 and 45 valves is +800°F (+427°C).
- Outlet pressure for temperatures above +100°F (+38°C) should not exceed the ANSI flange rating.
- Valves set below 15 psig (1.03 barg) cannot be stamped with the ASME Code Symbol. Only metal seated valves may be set below 15 psig.
- Series designations: JLTJOS-E and JLTJBS-E signify Series JOS-E, JBS-E with liquid trim for liquid and gas service.
- Optional 2½" outlet available. Contact the factory for dimensions.

#### LOW SET PRESSURE LIMITS

JOS-E	8 psig (0.55 barg)
JBS-E	15 psig (1.72 barg)
JLTJOS-E	15 psig (1.03 barg)
JLTJBS-E	25 psig (1.72 barg)

#### DIMENSIONS AND WEIGHTS

Valve series	Valve dimensions, inches (mm)							Approx. weight lbs (kg) type J
	Center to face		Use to find bolt length X	Approximate height Valve (cap) type				
	Inlet E	Outlet F		A and G	J and L	C	D	
<b>JOS-E-, JBS-E-, JLT-, JOS-H-E-</b>								
12, 14, 15, 16, 22, 24, 25, 26	4⅞ [105]	4½ [114]	1⅞ [40]	16¾ [426]	19¾ [502]	19 [483]	19½ [495]	36 [16]
32, 34, 35, 36, 37	4⅞ [105]	4½ [114]	1⅞ [40]	16¾ [426]	19¾ [502]	19 [483]	19½ [495]	36 [16]
42, 44, 45, 46, 47	4⅞ [105]	4½ [114]	1⅞ [40]	16¾ [426]	19¾ [502]	19 [483]	19½ [495]	36 [16]
<b>JOS-E-, JBS-E-, JLT-</b>								
55, 56, 57, 65, 66, 67	4⅞ [105]	5½ [140]	2 [51]	17½ [445]	20½ [521]	19¾ [502]	20¼ [514]	65 [29]
75, 76, 77 <sup>[5]</sup>	5½ [140]	7 [178]	2½ [64]	18¾ [477]	21¼ [552]	21 [533]	21½ [546]	75 [34]

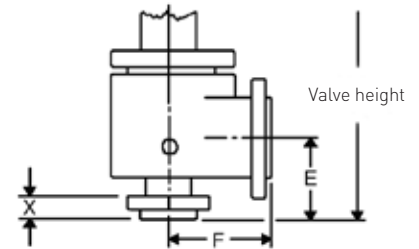

- Type J (Threaded Cap)
- Type C (Regular Lifting Lever) Also JOS-H-E
- Type D (Packed Lifting Lever)
- Type L (Bolted Cap)



# CROSBY J-SERIES

## DIRECT SPRING PRESSURE RELIEF VALVES

PRESSURE/TEMPERATURE LIMIT CHART - TO ANSI CLASS 600  
 E Orifice, 0.196 sq.in. (126 sq.mm) API effective area

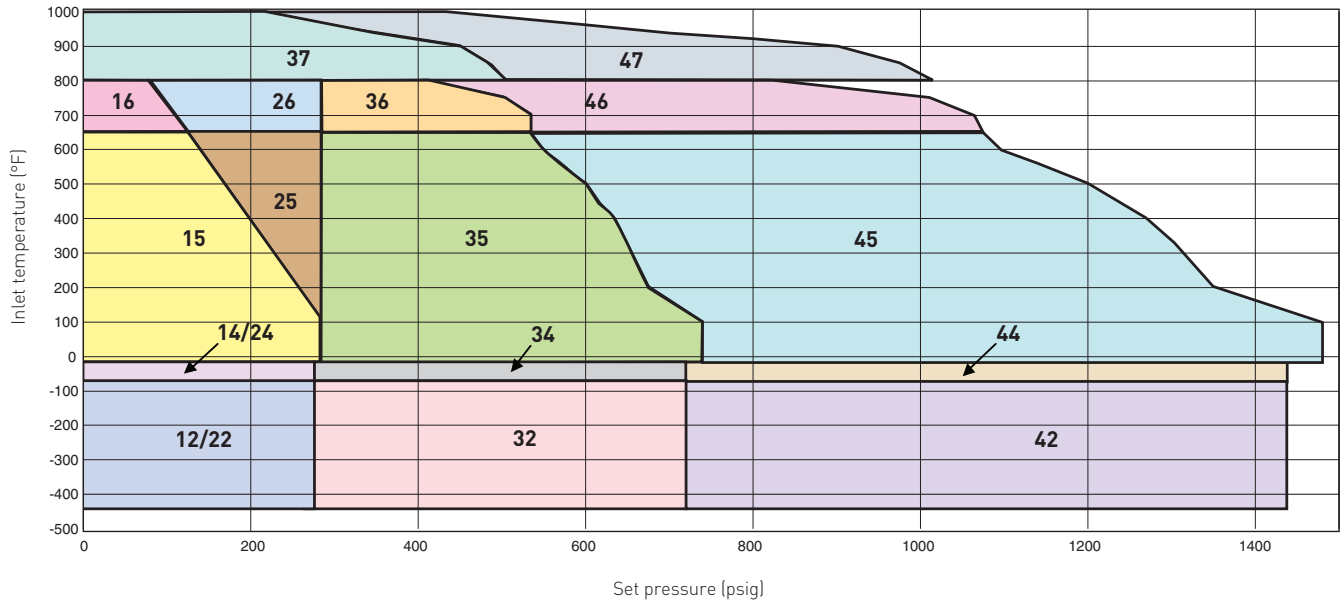

PRESSURE/TEMPERATURE LIMIT CHART - ANSI CLASS 900, CLASS 1500, CLASS 2500  
 E Orifice, 0.196 sq.in. (126 sq.mm) API effective area

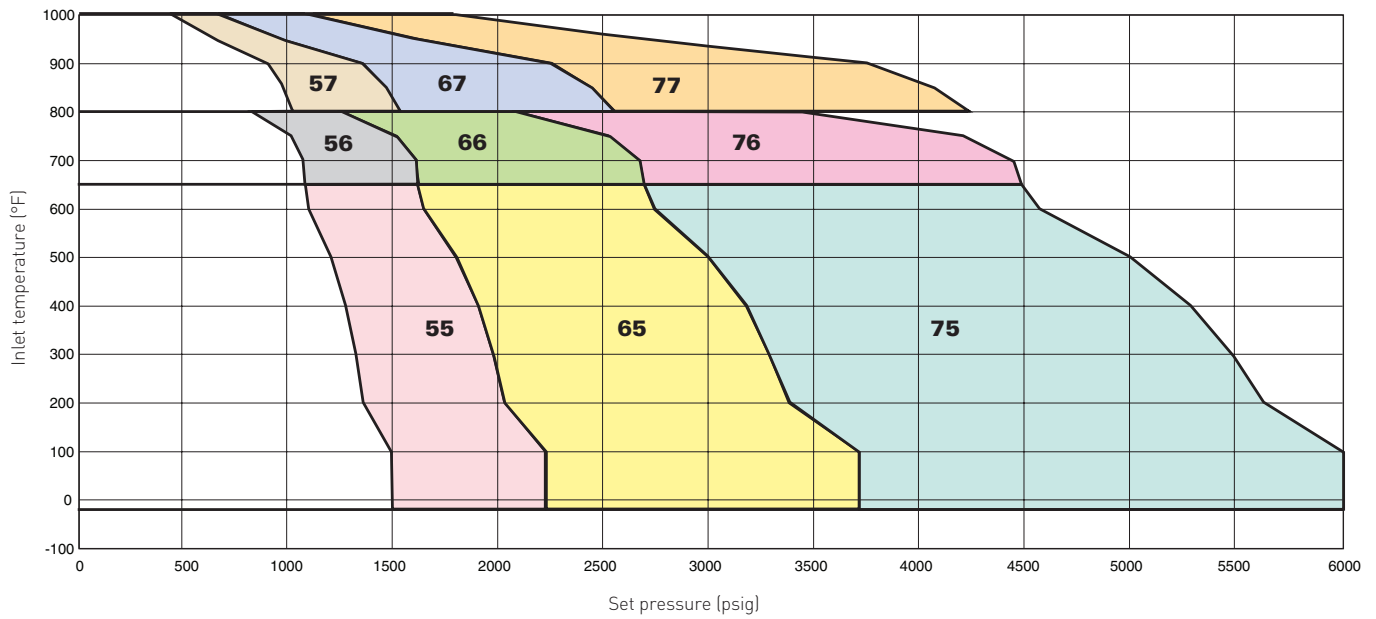

# CROSBY J-SERIES

## DIRECT SPRING PRESSURE RELIEF VALVES

### SIZES AND PRESSURE/TEMPERATURE LIMITS

#### F ORIFICE, 0.307 sq.in. (198 sq.mm) API EFFECTIVE AREA

Valve series	Valve size		Standard connections ANSI		Maximum set pressure psig (barg)						Back press. limit at 100°F psig (38°C barg)	
	Inlet X	Outlet	flanges raised face		Inlet						JOS <sup>[2]</sup>	JBS <sup>[2]</sup>
			Inlet	Outlet	-450°F to -76°F [-268°C to -60°C]	-75°F to -21°F [-59°C to -30°C]	-20°F to +100°F [-29°C to +38°C]	+650°F <sup>[1]</sup> [+343°C <sup>[1]</sup> ]	+800°F [+427°C]	+1000°F [+538°C]		
JOS-E-	15	1½ F2	150	150			285 (19.6)	125 (8.62)			285 (19.6)	230 (15.8)
JBS-E-	25	1½ F2	300	150			285 (19.6)	285 (19.6)			285 (19.6)	230 (15.8)
JLT-	35	1½ F2	300	150			740 (51.0)	535 (36.8)			285 (19.6)	230 (15.8)
JOS-H-E- <sup>[1]</sup>	45	1½ F2	600	150			1480 (102)	1075 (74.1)			285 (19.6)	230 (15.8)
JOS-E-	55	1½ F3 <sup>[5]</sup>	900	300			2220 (153)	1650 (111)			740 (51.0)	500 (34.4)
JBS-E-	65	1½ F3 <sup>[5]</sup>	1500	300			3705 (255)	2745 (185)			740 (51.0)	500 (34.4)
JLT-	75	1½ F3 <sup>[5]</sup>	2500	300			5000 (344)	4475 (308)			740 (51.0)	500 (34.4)
JOS-E-	16	1½ F2	150	150				125 (8.62)	80 (5.51)		285 (19.6)	230 (15.8)
JBS-E-	26	1½ F2	300	150				285 (19.6)	285 (19.6)		285 (19.6)	230 (15.8)
JLT-	36	1½ F2	300	150				535 (36.8)	410 (28.2)		285 (19.6)	230 (15.8)
	46	1½ F2	600	150				1075 (74.1)	825 (56.8)		285 (19.6)	230 (15.8)
JOS-E-	56	1½ F3 <sup>[5]</sup>	900	300				1650 (111)	1235 (85.1)		740 (51.0)	500 (34.4)
JBS-E-	66	1½ F3 <sup>[5]</sup>	1500	300				2745 (185)	2060 (142)		740 (51.0)	500 (34.4)
JLT-	76	1½ F3 <sup>[5]</sup>	2500	300				4475 (308)	3430 (236)		740 (51.0)	500 (34.4)
JOS-E-	37	1½ F2	300	150					510 (35.1)	215 (14.8)	285 (19.6)	230 (15.8)
JBS-E-	47	1½ F2	600	150					1015 (70)	430 (29.6)	285 (19.6)	230 (15.8)
JLT-												
JOS-E-	57	1½ F3 <sup>[5]</sup>	900	300					1525 (105)	650 (44.8)	740 (51.0)	500 (34.4)
JBS-E-	67	1½ F3 <sup>[5]</sup>	1500	300					2540 (175)	1080 (74.4)	740 (51.0)	500 (34.4)
JLT-	77	1½ F3 <sup>[5]</sup>	2500	300					4230 (291)	1800 (124)	740 (51.0)	500 (34.4)
JOS-E-	14	1½ F2	150	150		275 (18.9)					275 (18.9)	230 (15.8)
JBS-E-	24	1½ F2	300	150		275 (18.9)					275 (18.9)	230 (15.8)
JLT-	34	1½ F2	300	150		720 (49.6)					275 (18.9)	230 (15.8)
	44	1½ F2	600	150		1440 (99.3)					275 (18.9)	230 (15.8)
JOS-E-	12	1½ F2	150	150	275 (18.9)						275 (18.9)	230 (15.8)
JBS-E-	22	1½ F2	300	150	275 (18.9)						275 (18.9)	230 (15.8)
JLT-	32	1½ F2	300	150	720 (49.6)						275 (18.9)	230 (15.8)
	42	1½ F2	600	150	1440 (99.3)						275 (18.9)	230 (15.8)

#### NOTES

- Upper temperature limit of JOS-H-E-15, 25, 35 and 45 valves is +800°F (+427°C).
- Outlet pressure for temperatures above +100°F (+38°C) should not exceed the ANSI flange rating.
- Valves set below 15 psig (1.03 barg) cannot be stamped with the ASME Code Symbol. Only metal seated valves may be set below 15 psig.
- Series designations: JLTJOS-E and JLTJBS-E signify Series JOS-E, JBS-E with liquid trim for liquid and gas service.
- Optional 2½" outlet available. Contact the factory for dimensions.

#### LOW SET PRESSURE LIMITS

JOS-E	5 psig (0.34 barg)
JBS-E	10 psig (0.68 barg)
JLTJOS-E	15 psig (1.03 barg)
JLTJBS-E	25 psig (1.72 barg)

#### DIMENSIONS AND WEIGHTS

Valve series	Valve dimensions, inches (mm)							Approx. weight lbs (kg) type J
	Center to face		Use to find bolt length X	Approximate height Valve (cap) type				
	Inlet E	Outlet F		A and G	J and L	C	D	
<b>JOS-E-, JBS-E-, JLT-, JOS-H-E-</b>								
12, 14, 15, 16, 22, 24, 25, 26	4¾ (124)	4¾ (121)	1¾ (44)	20¼ (515)	23¼ (591)	22½ (572)	23¼ (591)	50 (23)
32, 34, 35, 36, 37	4¾ (124)	6 (152)	1¾ (44)	20¼ (515)	23¼ (591)	22½ (572)	23¼ (591)	50 (23)
42, 44, 45, 46, 47	4¾ (124)	6 (152)	1¾ (44)	20¼ (515)	23¼ (591)	22½ (572)	23¼ (591)	50 (23)
55, 56, 57, 65, 66, 67	4¾ (124)	6½ (165)	2 (51)	20 (508)	23 (584)	21¼ (540)	21¾ (552)	65 (29)
75, 76, 77 <sup>[5]</sup>	5½ (140)	7 (178)	2½ (64)	23 (584)	26¼ (679)	26 (660)	26¼ (679)	85 (39)

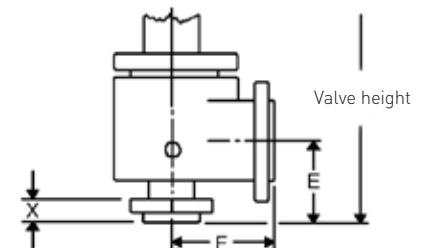

- Type J (Threaded Cap)
- Type C (Regular Lifting Lever) Also JOS-H-E
- Type D (Packed Lifting Lever)
- Type L (Bolted Cap)

**CROSBY J-SERIES**  
 DIRECT SPRING PRESSURE RELIEF VALVES

PRESSURE/TEMPERATURE LIMIT CHART - TO ANSI CLASS 600  
 F Orifice, 0.307 sq.in. (198 sq.mm) API effective area

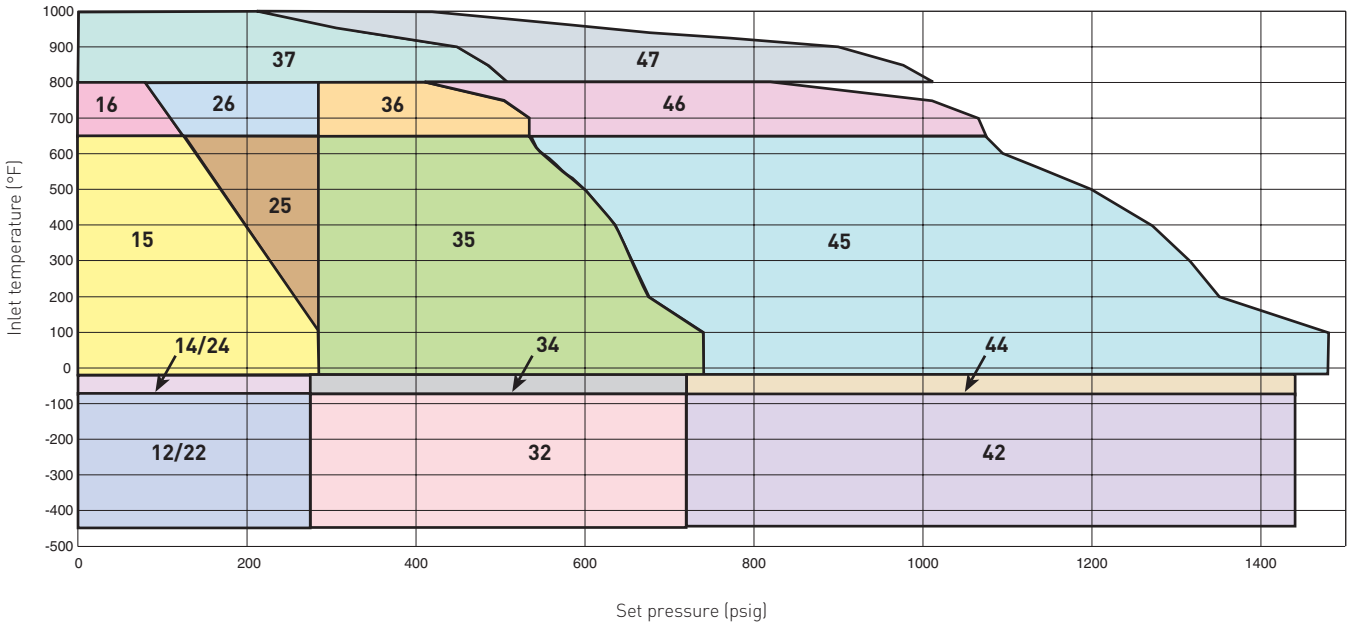

PRESSURE/TEMPERATURE LIMIT CHART - ANSI CLASS 900, CLASS 1500, CLASS 2500  
 F Orifice, 0.307 sq.in. (198 sq.mm) API effective area

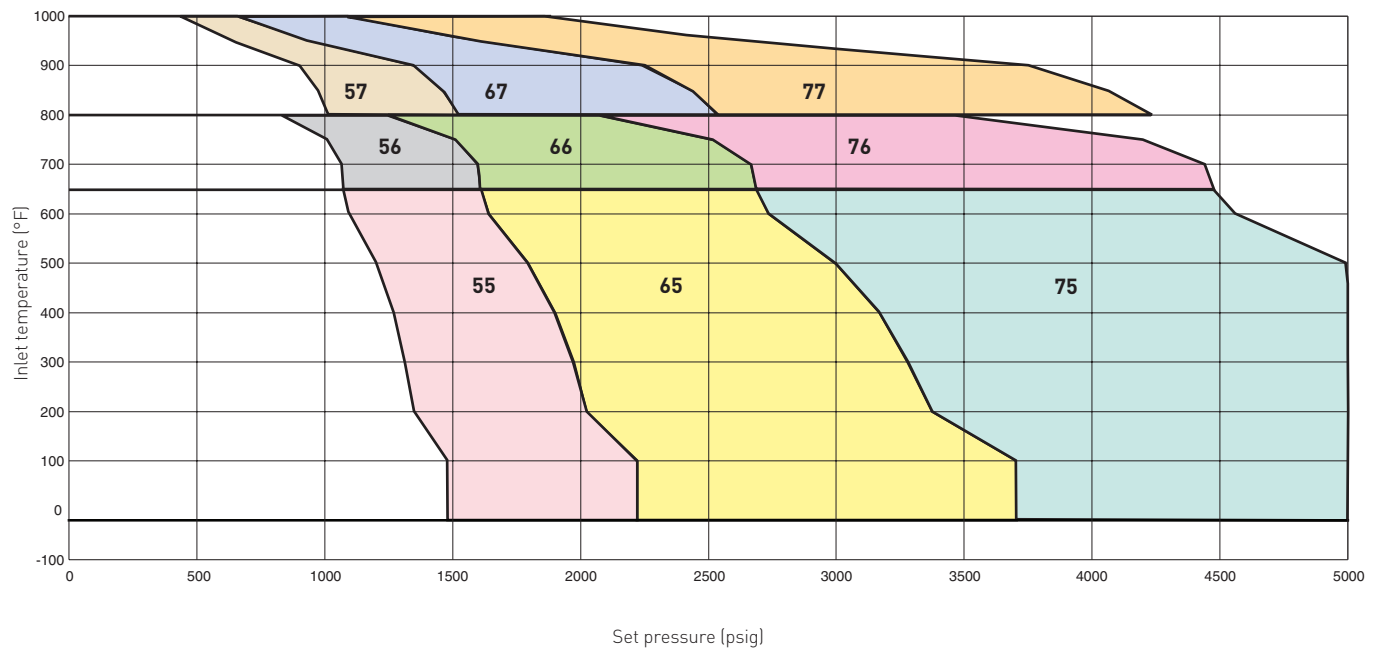

# CROSBY J-SERIES

## DIRECT SPRING PRESSURE RELIEF VALVES

### SIZES AND PRESSURE/TEMPERATURE LIMITS

#### G ORIFICE, 0.503 sq.in. (325 sq.mm) API EFFECTIVE AREA

Valve series	Valve size		Standard connections ANSI		Maximum set pressure psig (barg)					Back press. limit at 100°F psig (38°C barg)		
	Inlet X	Outlet X	flanges raised face		Inlet					JOS <sup>[2]</sup>	JBS <sup>[2]</sup>	
			Inlet	Outlet	-450°F to -76°F (-268°C to -60°C)	-75°F to -21°F (-59°C to -30°C)	-20°F to +100°F (-29°C to +38°C)	+650°F <sup>[1]</sup> (+343°C <sup>[1]</sup> )	+800°F (+427°C)			+1000°F (+538°C)
JOS-E-	15	1½ G3 <sup>[5]</sup>	150	150			285 (19.6)	125 (8.62)			285 (19.6)	230 (15.8)
JBS-E-	25	1½ G3 <sup>[5]</sup>	300	150			285 (19.6)	285 (19.6)			285 (19.6)	230 (15.8)
JLT-	35	1½ G3 <sup>[5]</sup>	300	150			740 (51.0)	535 (36.8)			285 (19.6)	230 (15.8)
JOS-H-E- <sup>[1]</sup>	45	1½ G3 <sup>[5]</sup>	600	150			1480 (102)	1075 (74.1)			285 (19.6)	230 (15.8)
JOS-E-	55	1½ G3 <sup>[5]</sup>	900	300			2220 (153)	1650 (111)			740 (51.0)	470 (32.4)
JBS-E-	65	2G3	1500	300			3705 (255)	2745 (185)			740 (51.0)	470 (32.4)
JLT-	75	2G3	2500	300			3705 (255)	3705 (255)			740 (51.0)	470 (32.4)
JOS-E-	16	1½ G3 <sup>[5]</sup>	150	150				125 (8.62)	80 (5.51)		285 (19.6)	230 (15.8)
JBS-E-	26	1½ G3 <sup>[5]</sup>	300	150				285 (19.6)	285 (19.6)		285 (19.6)	230 (15.8)
JLT-	36	1½ G3 <sup>[5]</sup>	300	150				535 (36.8)	410 (28.2)		285 (19.6)	230 (15.8)
	46	1½ G3 <sup>[5]</sup>	600	150				1075 (74.1)	825 (56.8)		285 (19.6)	230 (15.8)
JOS-E-	56	1½ G3 <sup>[5]</sup>	900	300				1650 (111)	1235 (85.1)		740 (51.0)	470 (32.4)
JBS-E-	66	2G3	1500	300				2745 (185)	2060 (142)		740 (51.0)	470 (32.4)
JLT-	76	2G3	2500	300				3705 (255)	3430 (236)		740 (51.0)	470 (32.4)
JOS-E-	37	1½ G3 <sup>[5]</sup>	300	150					510 (35.1)	215 (14.8)	285 (19.6)	230 (15.8)
JBS-E-	47	1½ G3 <sup>[5]</sup>	600	150					1015 (70)	430 (29.6)	285 (19.6)	230 (15.8)
JLT-												
JOS-E-	57	1½ G3 <sup>[5]</sup>	900	300					1525 (105)	650 (44.8)	740 (51.0)	470 (32.4)
JBS-E-	67	2G3	1500	300					2540 (175)	1080 (74.4)	740 (51.0)	470 (32.4)
JLT-	77	2G3	2500	300					3750 (255)	1800 (124)	740 (51.0)	500 (32.4)
JOS-E-	14	1½ G3 <sup>[5]</sup>	150	150		275 (18.9)					275 (18.9)	230 (15.8)
JBS-E-	24	1½ G3 <sup>[5]</sup>	300	150		275 (18.9)					275 (18.9)	230 (15.8)
JLT-	34	1½ G3 <sup>[5]</sup>	300	150		720 (49.6)					275 (18.9)	230 (15.8)
	44	1½ G3 <sup>[5]</sup>	600	150		1440 (99.3)					275 (18.9)	230 (15.8)
JOS-E-	12	1½ G3 <sup>[5]</sup>	150	150	275 (18.9)						275 (18.9)	230 (15.8)
JBS-E-	22	1½ G3 <sup>[5]</sup>	300	150	275 (18.9)						275 (18.9)	230 (15.8)
JLT-	32	1½ G3 <sup>[5]</sup>	300	150	720 (49.6)						275 (18.9)	230 (15.8)
	42	1½ G3 <sup>[5]</sup>	600	150	1440 (99.3)						275 (18.9)	230 (15.8)

#### NOTES

- Upper temperature limit of JOS-H-E-15, 25, 35 and 45 valves is +800°F (+427°C).
- Outlet pressure for temperatures above +100°F (+38°C) should not exceed the ANSI flange rating.
- Valves set below 15 psig (1.03 barg) cannot be stamped with the ASME Code Symbol. Only metal seated valves may be set below 15 psig.
- Series designations: JLTJOS-E and JLTJBS-E signify Series JOS-E, JBS-E with liquid trim for liquid and gas service.
- Optional 2½" outlet available. Contact the factory for dimensions.

#### LOW SET PRESSURE LIMITS

JOS-E	5 psig (0.34 barg)
JBS-E	15 psig (1.03 barg)
JLTJOS-E	15 psig (1.03 barg)
JLTJBS-E	25 psig (1.72 barg)

#### DIMENSIONS AND WEIGHTS

Valve series	Valve dimensions, inches (mm)							Approx. weight lbs (kg) type J
	Center to face		Use to find bolt length X	Approximate height Valve (cap) type				
	Inlet E	Outlet F		A and G	J and L	C	D	
<b>JOS-E, JBS-E, JLT-, JOS-H-E</b>								
12, 14, 15, 16, 22, 24, 25, 26 <sup>[5]</sup>	4⅞ (124)	4¾ (121)	1¾ (44)	20¼ (515)	23¼ (591)	22½ (572)	23¼ (591)	50 (23)
32, 34, 35, 36, 37, 47 <sup>[5]</sup>	4⅞ (124)	6 (152)	1¾ (44)	20¼ (515)	23¼ (591)	22½ (572)	23¼ (591)	50 (23)
42, 44, 45, 46 <sup>[5]</sup>	4⅞ (124)	6 (152)	1¾ (44)	20¼ (515)	23¼ (591)	22½ (572)	23¼ (591)	50 (23)
55, 56, 57 <sup>[5]</sup>	4⅞ (124)	6½ (165)	2 (51)	22¼ (566)	26 (660)	25¼ (641)	26 (660)	70 (32)
65, 66, 67, 75, 76, 77	6⅞ (155)	6¾ (171)	2¾ (70)	23¼ (591)	27 (686)	26¼ (667)	27 (686)	90 (41)

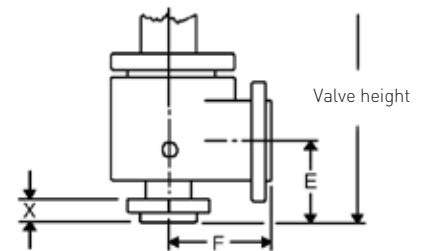

- Type J (Threaded Cap)
- Type C (Regular Lifting Lever) Also JOS-H-E
- Type D (Packed Lifting Lever)
- Type L (Bolted Cap)

# CROSBY J-SERIES

## DIRECT SPRING PRESSURE RELIEF VALVES

PRESSURE/TEMPERATURE LIMIT CHART - TO ANSI CLASS 600  
 G Orifice, 0.503 sq.in. (325 sq.mm) API effective area

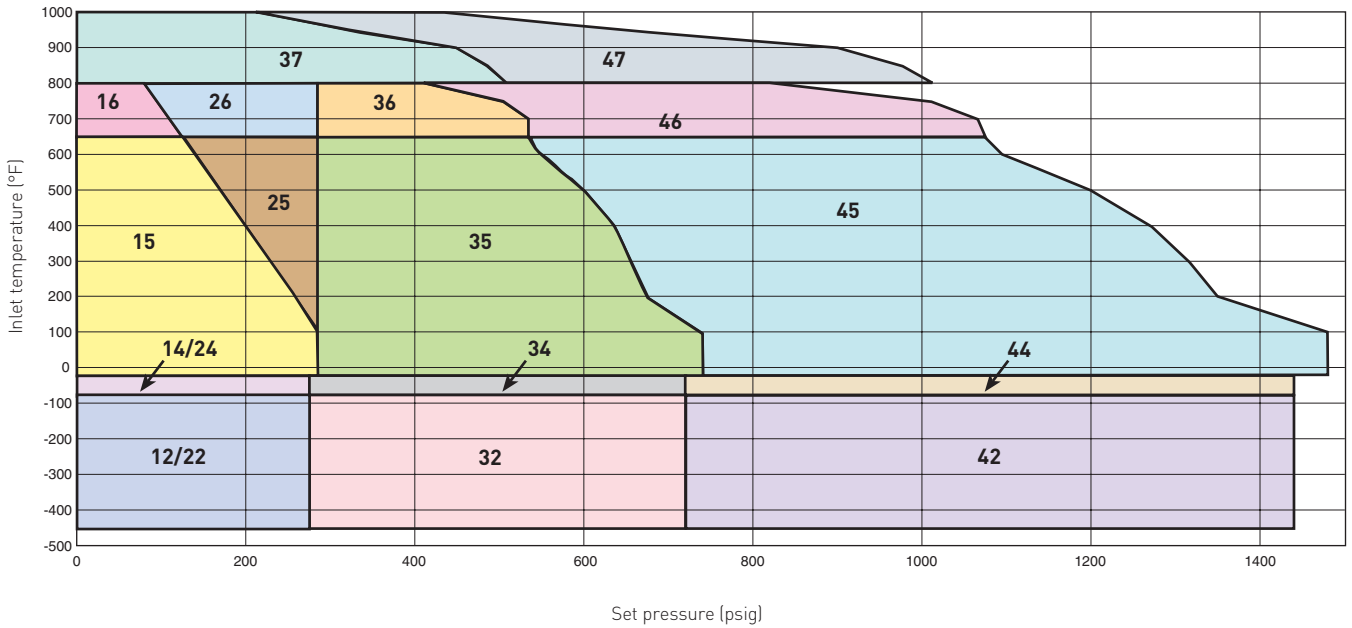

PRESSURE/TEMPERATURE LIMIT CHART - ANSI CLASS 900, CLASS 1500, CLASS 2500  
 G Orifice, 0.503 sq.in. (325 sq.mm) API effective area

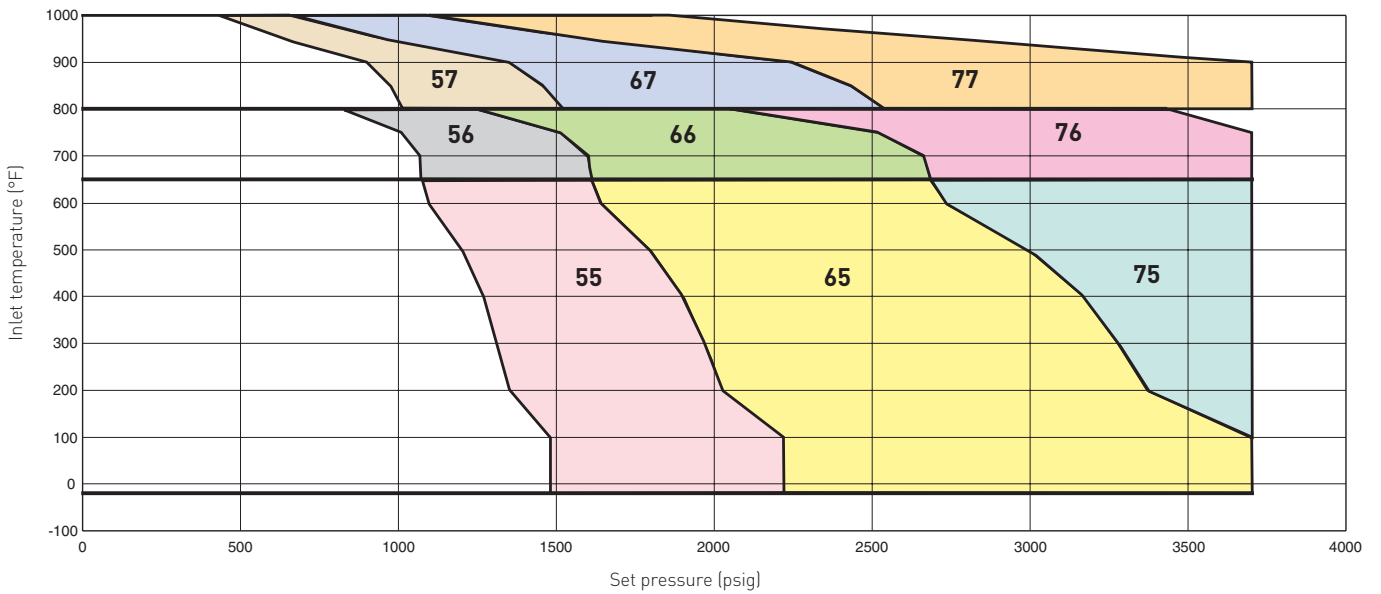

# CROSBY J-SERIES

## DIRECT SPRING PRESSURE RELIEF VALVES

### SIZES AND PRESSURE/TEMPERATURE LIMITS

#### H ORIFICE, 0.785 sq.in. (506 sq.mm) API EFFECTIVE AREA

Valve series	Valve size		Standard connections ANSI		Maximum set pressure psig (barg)						Back press. limit at 100°F psig (38°C barg)	
	Inlet X	Orifice X	flanges raised face		Inlet						JOS <sup>[2]</sup>	JBS <sup>[2]</sup>
	Outlet	Inlet	Outlet	-450°F to -76°F [-268°C to -60°C]	-75°F to -21°F [-59°C to -30°C]	-20°F to +100°F [-29°C to +38°C]	+650°F <sup>[1]</sup> [+343°C <sup>[1]</sup> ]	+800°F [+427°C]	+1000°F [+538°C]			
JOS-E-	15	1½ H3	150	150			285 (19.6)	125 (8.62)			285 (19.6)	230 (15.8)
JBS-E-	25	1½ H3	300	150			285 (19.6)	285 (19.6)			285 (19.6)	230 (15.8)
JLT-	35	2H3	300	150			740 (51.0)	535 (36.8)			285 (19.6)	230 (15.8)
JOS-H-E- <sup>[1]</sup>	45	2H3	600	150			1480 (102)	1075 (74.1)			285 (19.6)	230 (15.8)
JOS-E-	55	2H3	900	150			2220 (153)	1650 (111)			285 (19.6)	230 (15.8)
JBS-E-	65	2H3	1500	300			2750 (189)	2685 (185)			740 (51.0)	415 (28.6)
JLT-												
JOS-E-	16	1½ H3	150	150				125 (8.62)	80 (5.51)		285 (19.6)	230 (15.8)
JBS-E-	26	1½ H3	300	150				285 (19.6)	285 (19.6)		285 (19.6)	230 (15.8)
JLT-	36	2H3	300	150				535 (36.8)	410 (28.2)		285 (19.6)	230 (15.8)
	46	2H3	600	150				1075 (74.1)	825 (56.8)		285 (19.6)	230 (15.8)
JOS-E-	56	2H3	900	150				1610 (111)	1235 (85.1)		285 (19.6)	230 (15.8)
JBS-E-	66	2H3	1500	300				2685 (185)	2060 (142)		740 (51.0)	415 (28.6)
JLT-												
JOS-E-	37	2H3	300	150					510 (35.1)	215 (14.8)	285 (19.6)	230 (15.8)
JBS-E-	47	2H3	600	150					815 (56.2)	430 (29.6)	285 (19.6)	230 (15.8)
JLT-												
JOS-E-	57	2H3	900	150					1225 (84.4)	650 (44.8)	285 (19.6)	230 (15.8)
JBS-E-	67	2H3	1500	300					2040 (140)	1080 (74.4)	740 (51.0)	415 (28.6)
JLT-												
JOS-E-	14	1½ H3	150	150		275 (18.9)					275 (18.9)	230 (15.8)
JBS-E-	24	1½ H3	300	150		275 (18.9)					275 (18.9)	230 (15.8)
JLT-	34	2H3	300	150		720 (49.6)					275 (18.9)	230 (15.8)
	44	2H3	600	150		1440 (99.3)					275 (18.9)	230 (15.8)
JOS-E-	12	1½ H3	150	150	275 (18.9)						275 (18.9)	230 (15.8)
JBS-E-	22	1½ H3	300	150	275 (18.9)						275 (18.9)	230 (15.8)
JLT-	32	2H3	300	150	720 (49.6)						275 (18.9)	230 (15.8)
	42	2H3	600	150	1440 (99.3)						275 (18.9)	230 (15.8)

#### NOTES

- Upper temperature limit of JOS-H-E-15, 25, 35 and 45 valves is +800°F (+427°C).
- Outlet pressure for temperatures above +100°F (+38°C) should not exceed the ANSI flange rating.
- Valves set below 15 psig (1.03 barg) cannot be stamped with the ASME Code Symbol. Only metal seated valves may be set below 15 psig.
- Series designations: JLTJOS-E and JLTJBS-E signify Series JOS-E, JBS-E with liquid trim for liquid and gas service.

#### LOW SET PRESSURE LIMITS

JOS-E	5 psig (0.34 barg)
JBS-E	10 psig (0.68 barg)
JLTJOS-E	15 psig (1.03 barg)
JLTJBS-E	25 psig (1.72 barg)

#### DIMENSIONS AND WEIGHTS

Valve series	Valve dimensions, inches (mm)								Approx. weight lbs (kg) type J
	Center to face		Use to find bolt length X	Approximate height Valve (cap) type					
	Inlet E	Outlet F		A and G	J and L	C	D		
<b>JOS-E-, JBS-E-, JLT-, JOS-H-E-</b>									
12, 14, 15, 16, 22, 24, 25, 26	5½ (130)	4¾ (124)	1 11/16 (43)	20½ (521)	23½ (597)	22¾ (578)	23¼ (591)	55 (25)	
32, 34, 35, 36, 37, 47	5½ (130)	4¾ (124)	1 13/16 (46)	20½ (521)	23½ (597)	22¾ (578)	23¼ (591)	60 (27)	
42, 44, 45, 46	6 1/16 (154)	6¾ (162)	1 13/16 (46)	23 (585)	26¾ (679)	26 (660)	26¾ (679)	75 (34)	
55, 56, 57, 65, 66, 67	6 1/16 (154)	6¾ (162)	2 5/16 (59)	24½ (623)	28¼ (718)	27½ (699)	28¼ (718)	100 (50)	

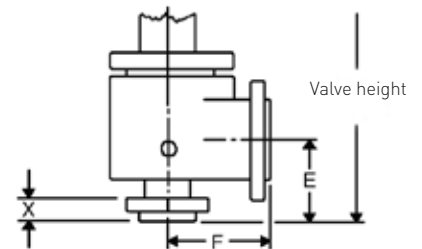

- Type J (Threaded Cap)
- Type C (Regular Lifting Lever) Also JOS-H-E
- Type D (Packed Lifting Lever)
- Type L (Bolted Cap)

# CROSBY J-SERIES

## DIRECT SPRING PRESSURE RELIEF VALVES

PRESSURE/TEMPERATURE LIMIT CHART - TO ANSI CLASS 600  
 H Orifice, 0.785 sq.in. (506 sq.mm) API effective area

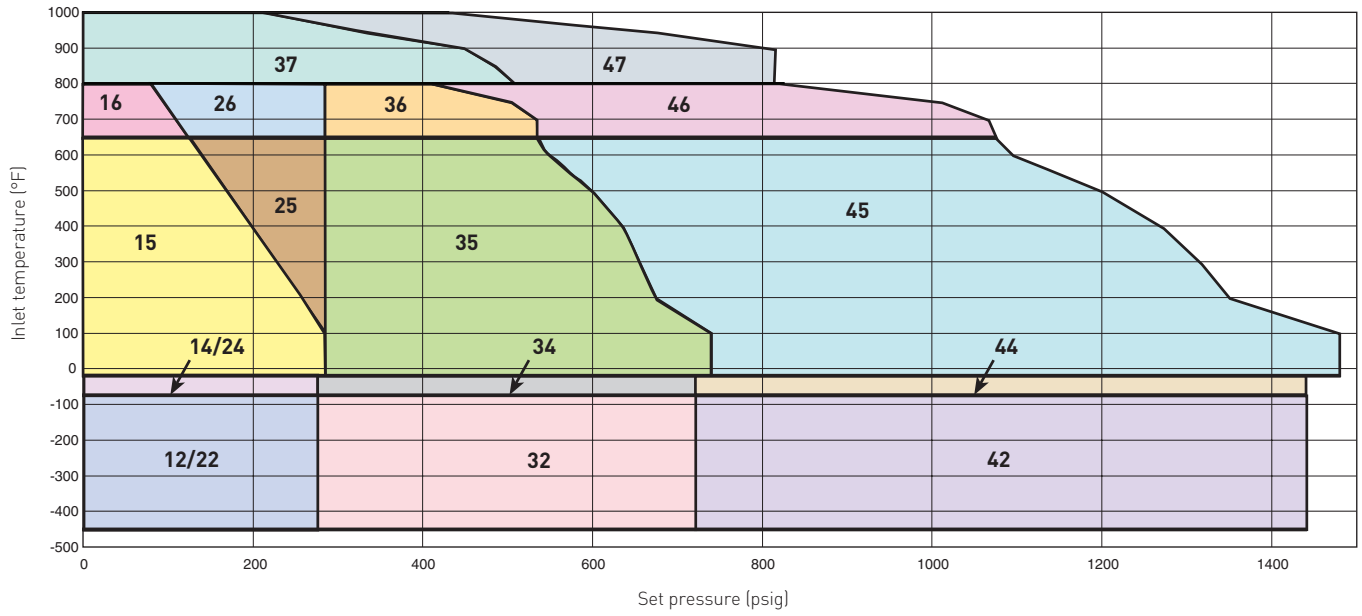

PRESSURE/TEMPERATURE LIMIT CHART - ANSI CLASS 900, CLASS 1500  
 H Orifice, 0.785 sq.in. (506 sq.mm) API effective area

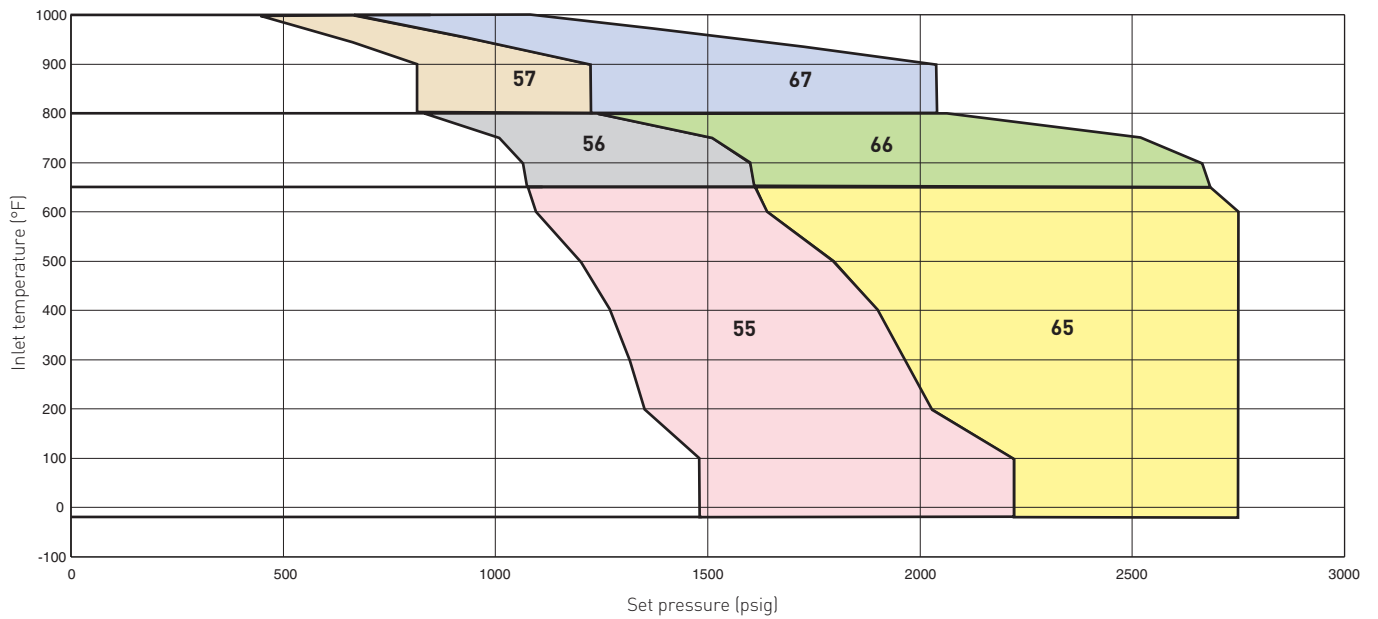

# CROSBY J-SERIES

## DIRECT SPRING PRESSURE RELIEF VALVES

### SIZES AND PRESSURE/TEMPERATURE LIMITS

#### J ORIFICE, 1.287 sq.in. (830 sq.mm) API EFFECTIVE AREA

Valve series	Valve size		Standard connections ANSI		Maximum set pressure psig (barg)					Back press. limit at 100°F psig (38°C barg)		
	Inlet X	Outlet X	flanges raised face		Inlet					JOS <sup>[2]</sup>	JBS <sup>[2]</sup>	
			Inlet	Outlet	-450°F to -76°F (-268°C to -60°C)	-75°F to -21°F (-59°C to -30°C)	-20°F to +100°F (-29°C to +38°C)	+650°F <sup>[1]</sup> (+343°C <sup>[1]</sup> )	+800°F (+427°C)			+1000°F (+538°C)
JOS-E-	15	2J3	150	150			285 (19.6)	125 (8.62)			285 (19.6)	230 (15.8)
JBS-E-	25	2J3	300	150			285 (19.6)	285 (19.6)			285 (19.6)	230 (15.8)
JLT-	35	3J4 <sup>[5]</sup>	300	150			740 (51.0)	535 (36.8)			285 (19.6)	230 (15.8)
JOS-H-E- <sup>[1]</sup>	45	3J4 <sup>[5]</sup>	600	150			1480 (102)	1075 (74.1)			285 (19.6)	230 (15.8)
JOS-E-	55	3J4	900	150			2220 (153)	1650 (111)			285 (19.6)	230 (15.8)
JBS-E-	65	3J4	1500	300			2700 (186)	2685 (185)			600 (41.3)	230 (15.8)
JLT-												
JOS-E-	16	2J3	150	150				125 (8.62)	80 (5.51)		285 (19.6)	230 (15.8)
JBS-E-	26	2J3	300	150				285 (19.6)	285 (19.6)		285 (19.6)	230 (15.8)
JLT-	36	3J4 <sup>[5]</sup>	300	150				535 (36.8)	410 (28.2)		285 (19.6)	230 (15.8)
	46	3J4 <sup>[5]</sup>	600	150				1075 (74.1)	825 (56.8)		285 (19.6)	230 (15.8)
JOS-E-	56	3J4	900	150				1610 (111)	1235 (85.1)		285 (19.6)	230 (15.8)
JBS-E- <sup>[5]</sup>	66	3J4	1500	300				2685 (186)	2060 (142)		600 (41.3)	230 (15.8)
JLT-												
JOS-E-	37	3J4 <sup>[5]</sup>	300	150					510 (35.1)	215 (14.8)	285 (19.6)	230 (15.8)
JBS-E-	47	3J4	600	150					815 (56.2)	430 (29.6)	285 (19.6)	230 (15.8)
JLT-												
JOS-E-	57	3J4 <sup>[5]</sup>	900	150					1225 (84.4)	650 (44.8)	285 (19.6)	230 (15.8)
JBS-E-	67	3J4	1500	300					2040 (140)	1080 (74.4)	600 (41.3)	230 (15.8)
JLT-												
JOS-E-	14	2J3	150	150		275 (18.9)					275 (18.9)	230 (15.8)
JBS-E-	24	2J3	300	150		275 (18.9)					275 (18.9)	230 (15.8)
JLT-	34	3J4 <sup>[5]</sup>	300	150		720 (49.6)					275 (18.9)	230 (15.8)
	44	3J4 <sup>[5]</sup>	600	150		1440 (99.3)					275 (18.9)	230 (15.8)
JOS-E-	12	2J3	150	150	275 (18.9)						275 (18.9)	230 (15.8)
JBS-E-	22	2J3	300	150	275 (18.9)						275 (18.9)	230 (15.8)
JLT-	32	3J4 <sup>[5]</sup>	300	150	500 (34.4)						275 (18.9)	230 (15.8)
	42	3J4 <sup>[5]</sup>	600	150	625 (43.1)						275 (18.9)	230 (15.8)

#### NOTES

- Upper temperature limit of JOS-H-E-15, 25, 35 and 45 valves is +800°F (+427°C).
- Outlet pressure for temperatures above +100°F (+38°C) should not exceed the ANSI flange rating.
- Valves set below 15 psig (1.03 barg) cannot be stamped with the ASME Code Symbol. Only metal seated valves may be set below 15 psig.
- Series designations: JLTJOS-E and JLTJBS-E signify Series JOS-E, JBS-E with liquid trim for liquid and gas service.
- Optional 2½" inlet available. Contact the factory for dimensions.

#### LOW SET PRESSURE LIMITS

JOS-E	5 psig (0.34 barg)
JBS-E	9 psig (0.62 barg)
JLTJOS-E	15 psig (1.03 barg)
JLTJBS-E	25 psig (1.72 barg)

#### DIMENSIONS AND WEIGHTS

Valve series	Valve dimensions, inches (mm)								Approx. weight lbs (kg) type J
	Center to face		Use to find bolt length X	Approximate height Valve (cap) type					
	Inlet E	Outlet F		A and G	J and L	C	D		
<b>JOS-E-, JBS-E-, JLT-, JOS-H-E-</b>									
12, 14, 15, 16, 22, 24, 25, 26	5¾ (137)	4¾ (124)	1 11/16 (43)	20¾ (527)	23¾ (603)	23¼ (591)	23¾ (603)	66 (30)	
32, 34, 35, 36, 37, 47	7¼ (184)	7½ (181)	2¼ (57)	24¾ (632)	28¾ (727)	27¾ (703)	28¾ (727)	100 (45)	
42, 44, 45, 46	7¼ (184)	7½ (181)	2¼ (57)	26¾ (683)	30¾ (773)	29¾ (759)	30¾ (778)	128 (57)	
57	7¼ (184)	7½ (181)	2 11/16 (68)	26¾ (683)	30¾ (773)	29¾ (759)	30¾ (778)	151 (68)	
55, 56, 65, 66, 67	7¼ (184)	7½ (181)	2 11/16 (68)	28¾ (826)	32½ (826)	31¾ (806)	32½ (826)	155 (70)	

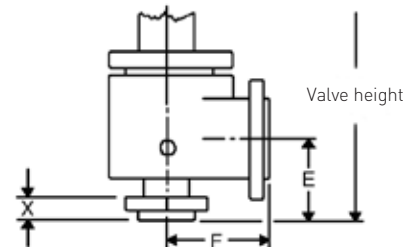

- Type J (Threaded Cap)
- Type C (Regular Lifting Lever) Also JOS-H-E
- Type D (Packed Lifting Lever)
- Type L (Bolted Cap)



**CROSBY J-SERIES**  
 DIRECT SPRING PRESSURE RELIEF VALVES

PRESSURE/TEMPERATURE LIMIT CHART - TO ANSI CLASS 600  
 J Orifice, 1.287 sq.in. (830 sq.mm) API effective area

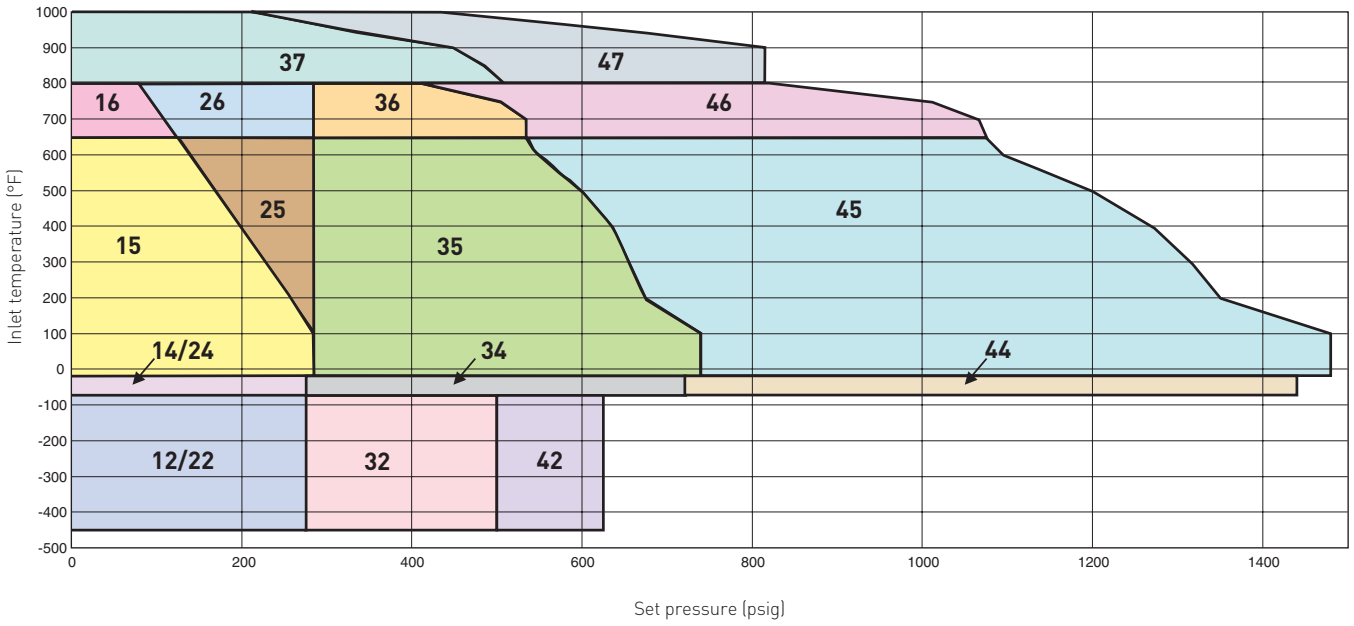

PRESSURE/TEMPERATURE LIMIT CHART - ANSI CLASS 900, CLASS 1500  
 J Orifice, 1.287 sq.in. (830 sq.mm) API effective area

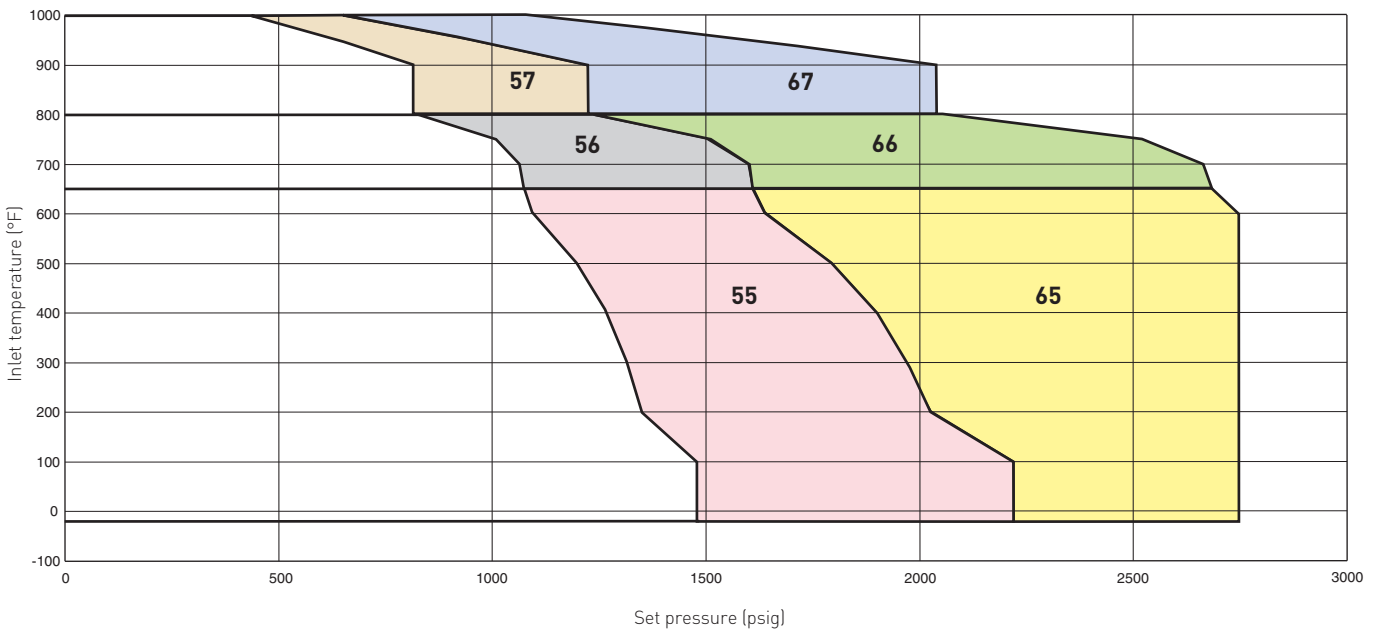

# CROSBY J-SERIES

## DIRECT SPRING PRESSURE RELIEF VALVES

### SIZES AND PRESSURE/TEMPERATURE LIMITS

#### K ORIFICE, 1.838 sq.in. (1186 sq.mm) API EFFECTIVE AREA

Valve series	Valve size		Standard connections ANSI		Maximum set pressure psig (barg)					Back press. limit at 100°F psig (38°C barg)		
	Inlet X	Orifice X	flanges raised face		Inlet					JOS <sup>[2]</sup>	JBS <sup>[2]</sup>	
	Outlet	Inlet	Outlet	-450°F to -76°F (-268°C to -60°C)	-75°F to -21°F (-59°C to -30°C)	-20°F to +100°F (-29°C to +38°C)	+650°F <sup>[1]</sup> (+343°C <sup>[1]</sup> )	+800°F (+427°C)	+1000°F (+538°C)			
JOS-E-	15	3K4	150	150			285 (19.6)	125 (8.62)			285 (19.6)	150 (10.3)
JBS-E-	25	3K4	300	150			285 (19.6)	285 (19.6)			285 (19.6)	150 (10.3)
JLT-	35	3K4	300	150			740 (51.0)	535 (36.8)			285 (19.6)	150 (10.3)
JOS-H-E- <sup>[1]</sup>	45	3K4	600	150			1480 (102)	1075 (74.1)			285 (19.6)	200 (13.7)
JOS-E-	55	3K6	900	150			2220 (153)	1610 (111)			285 (19.6)	200 (13.7)
JBS-E-	65	3K6	1500	300			2220 (153)	2220 (153)			600 (41.3)	200 (13.7)
JLT-												
JOS-E-	16	3K4	150	150				125 (8.62)	80 (5.51)		285 (19.6)	150 (10.3)
JBS-E-	26	3K4	300	150				285 (19.6)	285 (19.6)		285 (19.6)	150 (10.3)
JLT-	36	3K4	300	150				535 (36.8)	410 (28.2)		285 (19.6)	150 (10.3)
	46	3K4	600	150				1075 (74.1)	825 (56.8)		285 (19.6)	200 (13.7)
JOS-E-	56	3K6	900	150				1610 (127)	1235 (85.1)		285 (19.6)	200 (13.7)
JBS-E-	66	3K6	1500	300				2220 (153)	2060 (142)		600 (41.3)	200 (13.7)
JLT-												
JOS-E-												
JBS-E-	37	3K4	300	150					510 (35.1)	215 (14.8)	285 (19.6)	150 (10.3)
JLT-	47	3K4	600	150					815 (56.2)	430 (29.6)	285 (19.6)	200 (13.7)
JOS-E-	57	3K6	900	150					1225 (84.4)	650 (44.8)	285 (19.6)	200 (13.7)
JBS-E-	67	3K6	1500	300					2040 (140)	1080 (74.4)	600 (41.3)	200 (13.7)
JLT-												
JOS-E-	14	3K4	150	150		275 (18.9)					275 (18.9)	150 (10.3)
JBS-E-	24	3K4	300	150		275 (18.9)					275 (18.9)	150 (10.3)
JLT-	34	3K4	300	150		720 (49.6)					275 (18.9)	150 (10.3)
	44	3K4	600	150		1440 (99.3)					275 (18.9)	200 (13.7)
JOS-E-	12	3K4	150	150	275 (18.9)						275 (18.9)	150 (10.3)
JBS-E-	22	3K4	300	150	275 (18.9)						275 (18.9)	150 (10.3)
JLT-	32	3K4	300	150	525 (36.2)						275 (18.9)	150 (10.3)
	42	3K4	600	150	600 (41.3)						275 (18.9)	200 (13.7)

#### NOTES

- Upper temperature limit of JOS-H-E-15, 25, 35 and 45 valves is +800°F (+427°C).
- Outlet pressure for temperatures above +100°F (+38°C) should not exceed the ANSI flange rating.
- Valves set below 15 psig (1.03 barg) cannot be stamped with the ASME Code Symbol. Only metal seated valves may be set below 15 psig.
- Series designations: JLTJOS-E and JLTJBS-E signify Series JOS-E, JBS-E with liquid trim for liquid and gas service.

#### LOW SET PRESSURE LIMITS

JOS-E	5 psig (0.34 barg)
JBS-E	9 psig (0.62 barg)
JLTJOS-E	15 psig (1.03 barg)
JLTJBS-E	25 psig (1.72 barg)

#### DIMENSIONS AND WEIGHTS

Valve series	Valve dimensions, inches (mm)							Approx. weight lbs (kg) type J
	Center to face		Use to find bolt length X	Approximate height Valve (cap) type				
	Inlet E	Outlet F		A and G	J and L	C	D	
<b>JOS-E-, JBS-E-, JLT-, JOS-H-E-</b>								
12, 14, 15, 16, 22, 24, 25, 26	6 1/8 (156)	6 3/8 (162)	2 1/8 (54)	26 (661)	29 3/4 (756)	29 (737)	29 3/4 (756)	116 (52)
32, 34, 35, 36, 37, 47	6 1/8 (156)	6 3/8 (162)	2 1/8 (54)	26 (661)	29 3/4 (756)	29 (737)	29 3/4 (756)	117 (53)
42, 44, 45, 46	7 1/4 (184)	7 1/8 (181)	2 1/8 (54)	29 1/4 (743)	33 (838)	32 1/2 (826)	33 1/4 (845)	160 (73)
55, 56, 57	7 13/16 (198)	8 1/2 (216)	2 11/16 (68)	33 1/2 (851)	39 (991)	38 (965)	38 3/4 (984)	185 (84)
65, 66, 67	7 3/4 (197)	8 1/2 (216)	2 11/16 (68)	33 1/2 (851)	39 (991)	38 (965)	38 3/4 (984)	195 (88)

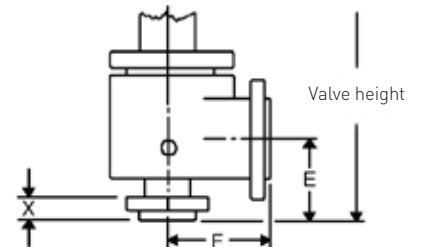

- Type J (Threaded Cap)
- Type C (Regular Lifting Lever) Also JOS-H-E
- Type D (Packed Lifting Lever)
- Type L (Bolted Cap)

**CROSBY J-SERIES**  
 DIRECT SPRING PRESSURE RELIEF VALVES

PRESSURE/TEMPERATURE LIMIT CHART - TO ANSI CLASS 600  
 K Orifice, 1.838 sq.in. (1186 sq.mm) API effective area

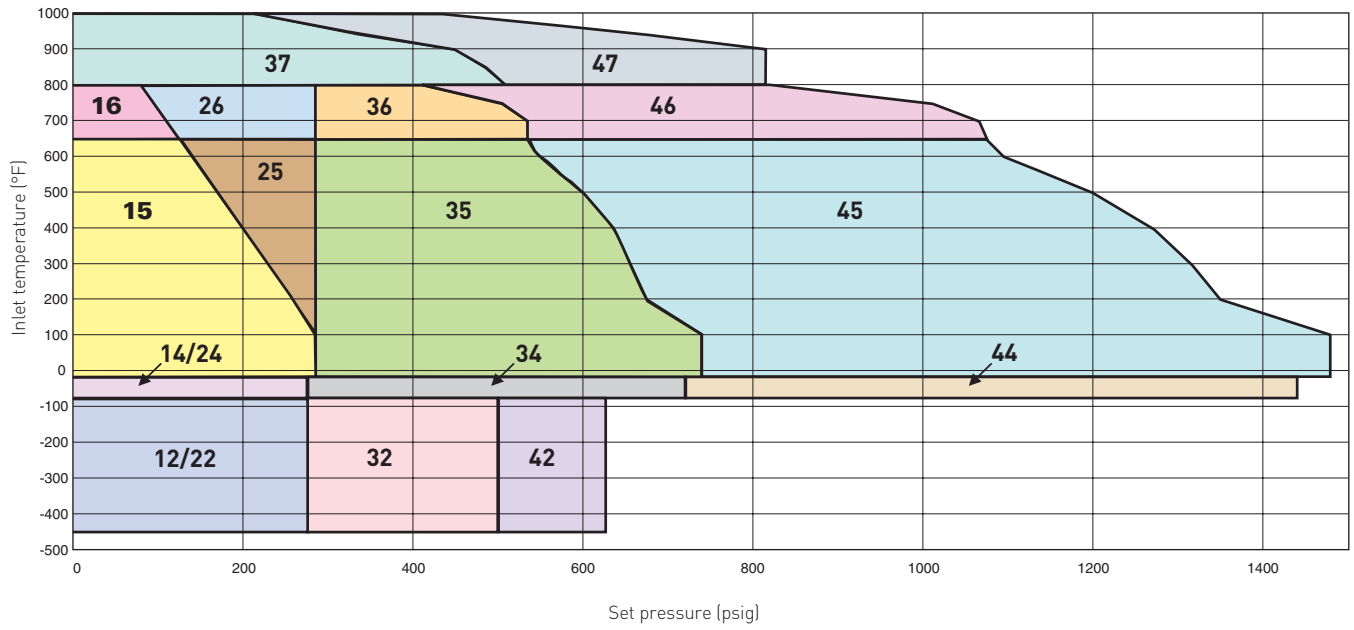

PRESSURE/TEMPERATURE LIMIT CHART - ANSI CLASS 900, CLASS 1500  
 K Orifice, 1.838 sq.in. (1186 sq.mm) API effective area

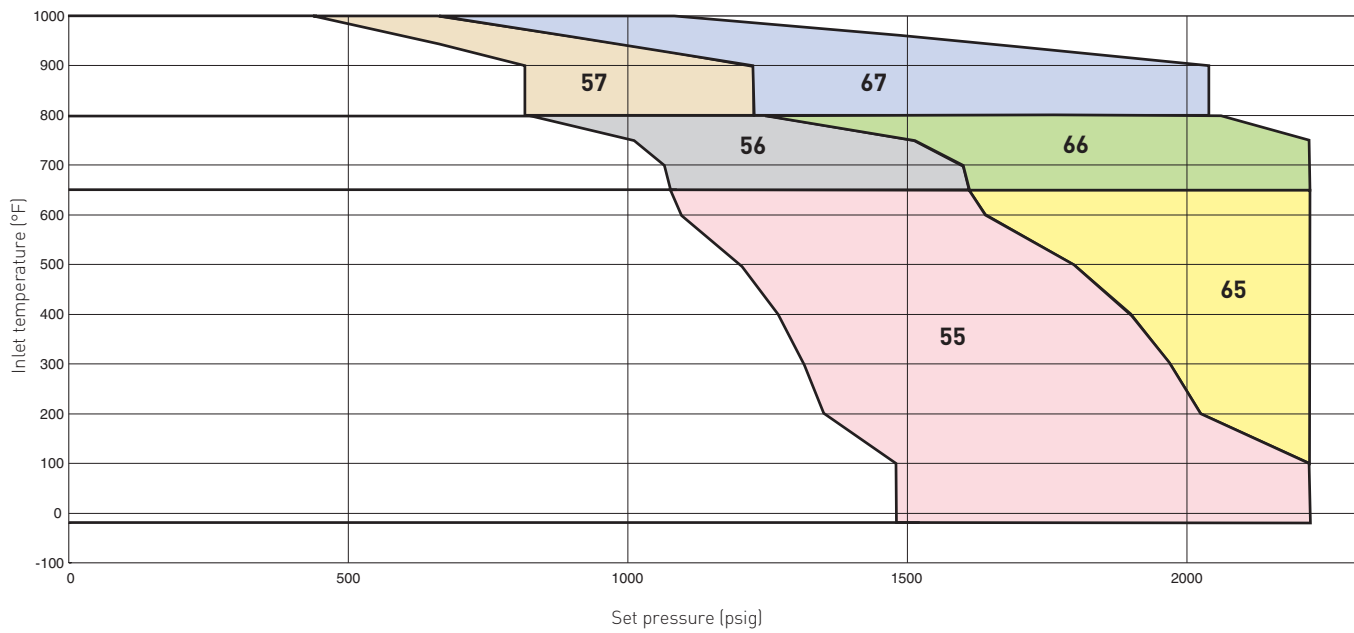

# CROSBY J-SERIES

## DIRECT SPRING PRESSURE RELIEF VALVES

### SIZES AND PRESSURE/TEMPERATURE LIMITS

#### L ORIFICE, 2.853 sq.in. (1841 sq.mm) API EFFECTIVE AREA

Valve series	Valve size		Standard connections ANSI		Maximum set pressure psig (barg)					Back press. limit at 100°F psig (38°C barg)		
	Inlet X	Orifice X	flanges raised face		Inlet					JOS <sup>[2]</sup>	JBS <sup>[2]</sup>	
	Outlet	Inlet	Outlet	-450°F to -76°F (-268°C to -60°C)	-75°F to -21°F (-59°C to -30°C)	-20°F to +100°F (-29°C to +38°C)	+650°F <sup>[1]</sup> (+343°C <sup>[1]</sup> )	+800°F (+427°C)	+1000°F (+538°C)			
JOS-E-	15	3L4	150	150			285 (19.6)	125 (8.62)			285 (19.6)	100 (6.89)
JBS-E-	25	3L4	300	150			285 (19.6)	285 (19.6)			285 (19.6)	100 (6.89)
JLT-	35	4L6	300	150			740 (51.0)	535 (36.8)			285 (19.6)	170 (11.7)
JOS-H-E- <sup>[1]</sup>	45	4L6	600	150			1000 (68.9)	1000 (68.9)			285 (19.6)	170 (11.7)
JOS-E-	55	4L6	900	150			1500 (103)	1500 (103)			285 (19.6)	170 (11.7)
JBS-E-												
JLT-												
JOS-E-	16	3L4	150	150				125 (8.62)	80 (5.51)		285 (19.6)	100 (6.89)
JBS-E-	26	3L4	300	150				285 (19.6)	285 (19.6)		285 (19.6)	100 (6.89)
JLT-	36	4L6	300	150				535 (36.8)	410 (28.2)		285 (19.6)	170 (11.7)
	46	4L6	600	150				1000 (68.9)	825 (56.8)		285 (19.6)	170 (11.7)
JOS-E-	56	4L6	900	150				1500 (103)	1235 (85.1)		285 (19.6)	170 (11.7)
JBS-E-	66	4L6	1500	150				1500 (103)	1500 (103)		285 (19.6)	170 (11.7)
JLT-												
JOS-E-	37	4L6	300	150					510 (35.1)	215 (14.8)	285 (19.6)	170 (11.7)
JBS-E-	47	4L6	600	150					1000 (68.9)	430 (29.6)	285 (19.6)	170 (11.7)
JLT-												
JOS-E-	57	4L6	900	150					1500 (103)	650 (44.8)	285 (19.6)	170 (11.7)
JBS-E-	67	4L6	1500	150					1500 (103)	1080 (74.4)	285 (19.6)	170 (11.7)
JLT-												
JOS-E-	14	3L4	150	150		275 (18.9)					275 (18.9)	100 (6.89)
JBS-E-	24	3L4	300	150		275 (18.9)					275 (18.9)	100 (6.89)
JLT-	34	4L6	300	150		720 (49.6)					275 (18.9)	170 (11.7)
	44	4L6	600	150		1000 (68.9)					275 (18.9)	170 (11.7)
JOS-E-	12	3L4	150	150	275 (18.9)						275 (18.9)	100 (6.89)
JBS-E-	22	3L4	300	150	275 (18.9)						275 (18.9)	100 (6.89)
JLT-	32	4L6	300	150	535 (36.8)						275 (18.9)	170 (11.7)
	42	4L6	600	150	535 (36.8)						275 (18.9)	170 (11.7)

#### NOTES

- Upper temperature limit of JOS-H-E-15, 25, 35 and 45 valves is +800°F (+427°C).
- Outlet pressure for temperatures above +100°F (+38°C) should not exceed the ANSI flange rating.
- Valves set below 15 psig (1.03 barg) cannot be stamped with the ASME Code Symbol. Only metal seated valves may be set below 15 psig.
- Series designations: JLTJOS-E and JLTJBS-E signify Series JOS-E, JBS-E with liquid trim for liquid and gas service.

#### LOW SET PRESSURE LIMITS

JOS-E	6 psig (0.41 barg)
JBS-E	8 psig (0.55 barg)
JLTJOS-E	15 psig (1.03 barg)
JLTJBS-E	25 psig (1.72 barg)

#### DIMENSIONS AND WEIGHTS

Valve series	Valve dimensions, inches (mm)								Approx. weight lbs (kg) type J
	Center to face		Use to find bolt length X	Approximate height Valve (cap) type					
	Inlet E	Outlet F		A and G	J and L	C	D		
<b>JOS-E-, JBS-E-, JLT-, JOS-H-E-</b>									
12, 14, 15, 16, 22, 24, 25, 26	6 1/8 (156)	6 1/2 (165)	2 (51)	30 1/4 (769)	34 (864)	33 1/4 (845)	34 (864)		152 (69)
32, 34, 35, 36, 37	7 1/8 (179)	7 1/8 (181)	2 1/8 (54)	30 1/4 (769)	34 (864)	34 1/4 (870)	34 1/4 (870)		192 (87)
42, 44, 45, 46, 47	7 1/8 (179)	8 (203)	2 3/8 (60)	31 1/2 (801)	35 1/4 (895)	34 3/4 (883)	35 1/4 (895)		226 (103)
55, 56, 57, 66, 67	7 3/4 (197)	8 3/4 (222)	2 5/8 (75)	34 1/4 (871)	39 3/4 (1010)	38 3/4 (984)	39 1/2 (1003)		270 (122)

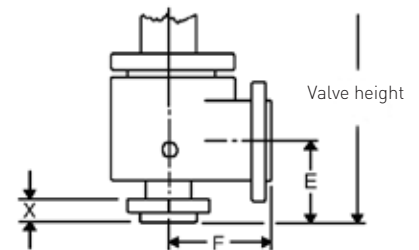

- Type J (Threaded Cap)
- Type C (Regular Lifting Lever) Also JOS-H-E
- Type D (Packed Lifting Lever)
- Type L (Bolted Cap)

# CROSBY J-SERIES

## DIRECT SPRING PRESSURE RELIEF VALVES

PRESSURE/TEMPERATURE LIMIT CHART  
 L Orifice, 2.853 sq.in. [1841 sq.mm] API effective area

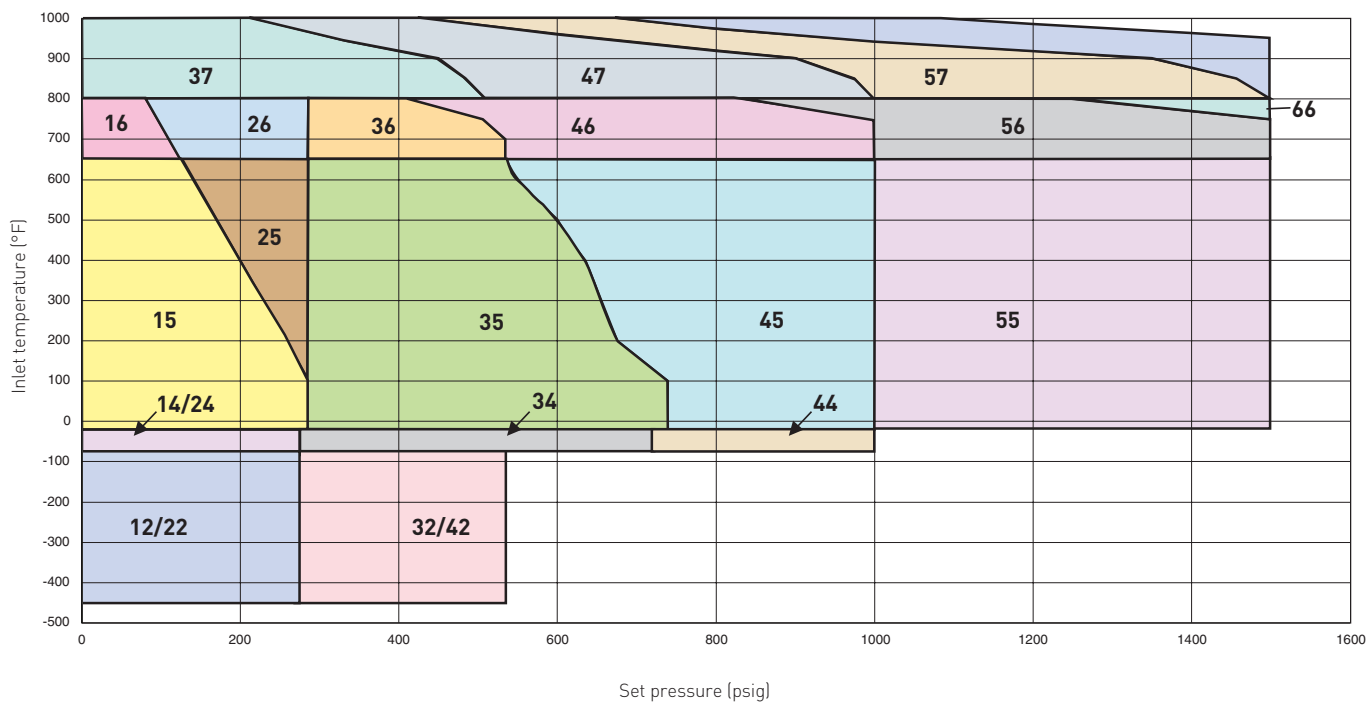

# CROSBY J-SERIES

## DIRECT SPRING PRESSURE RELIEF VALVES

### SIZES AND PRESSURE/TEMPERATURE LIMITS

#### M ORIFICE, 3.60 sq.in. (2323 sq.mm) API EFFECTIVE AREA

Valve series	Valve size		Standard connections ANSI		Maximum set pressure psig (barg)						Back press. limit at 100°F psig (38°C barg)	
	Inlet X	Orifice X	flanges raised face		Inlet						JOS <sup>[2]</sup>	JBS <sup>[2]</sup>
	Outlet	Inlet	Outlet	-450°F to -76°F [-268°C to -60°C]	-75°F to -21°F [-59°C to -30°C]	-20°F to +100°F [-29°C to +38°C]	+650°F <sup>[1]</sup> [+343°C <sup>[1]</sup> ]	+800°F [+427°C]	+1000°F [+538°C]			
JOS-E-	15	4M6	150	150			285 (19.6)	125 (8.62)			285 (19.6)	80 (5.51)
JBS-E-	25	4M6	300	150			285 (19.6)	285 (19.6)			285 (19.6)	80 (5.51)
JLT-	35	4M6	300	150			740 (51.0)	535 (36.8)			285 (19.6)	160 (11.0)
JOS-H-E- <sup>[1]</sup>	45	4M6	600	150			1100 (75.8)	1075 (74.1)			285 (19.6)	160 (11.0)
JOS-E-	16	4M6	150	150				125 (8.62)	80 (5.51)		285 (19.6)	80 (5.51)
JBS-E-	26	4M6	300	150				285 (19.6)	285 (19.6)		285 (19.6)	80 (5.51)
JLT-	36	4M6	300	150				535 (36.8)	410 (28.2)		285 (19.6)	160 (11.0)
	46	4M6	600	150				1075 (74.1)	825 (56.8)		285 (19.6)	160 (11.0)
JOS-E-												
JBS-E-	56	4M6	900	150				1100 (75.8)	1100 (75.8)		285 (19.6)	160 (11.0)
JLT-												
JOS-E-												
JBS-E-	37	4M6	300	150					510 (35.1)	215 (14.8)	285 (19.6)	160 (11.0)
JLT-	47	4M6	600	150					1015 (70)	430 (29.6)	285 (19.6)	160 (11.0)
JOS-E-												
JBS-E-												
JLT-	57	4M6	900	150					1100 (75.8)	650 (44.8)	285 (19.6)	160 (11.0)
JOS-E-	14	4M6	150	150		275 (18.9)					275 (18.9)	80 (5.51)
JBS-E-	24	4M6	300	150		275 (18.9)					275 (18.9)	80 (5.51)
JLT-	34	4M6	300	150		720 (49.6)					275 (18.9)	160 (11.0)
	44	4M6	600	150		1100 (75.8)					275 (18.9)	160 (11.0)
JOS-E-	12	4M6	150	150	275 (18.9)						275 (18.9)	80 (5.51)
JBS-E-	22	4M6	300	150	275 (18.9)						275 (18.9)	80 (5.51)
JLT-	32	4M6	300	150	525 (36.2)						275 (18.9)	160 (11.0)
	42	4M6	600	150	600 (41.3)						275 (18.9)	160 (11.0)

#### NOTES

- Upper temperature limit of JOS-H-E-15, 25, 35 and 45 valves is +800°F (+427°C).
- Outlet pressure for temperatures above +100°F (+38°C) should not exceed the ANSI flange rating.
- Valves set below 15 psig (1.03 barg) cannot be stamped with the ASME Code Symbol. Only metal seated valves may be set below 15 psig.
- Series designations: JLTJOS-E and JLTJBS-E signify Series JOS-E, JBS-E with liquid trim for liquid and gas service.

#### LOW SET PRESSURE LIMITS

JOS-E	8 psig (0.55 barg)
JBS-E	10 psig (0.68 barg)
JLTJOS-E	15 psig (1.03 barg)
JLTJBS-E	25 psig (1.72 barg)

#### DIMENSIONS AND WEIGHTS

Valve series	Valve dimensions, inches (mm)								Approx. weight lbs (kg)
	Center to face		Use to find bolt length	Approximate height				type J	
	Inlet E	Outlet F		A and G	J and L	C	D		
<b>JOS-E-, JBS-E-, JLT-, JOS-H-E-</b>									
12, 14, 15, 16, 22, 24, 25, 26	7 (178)	7 1/4 (184)	2 1/8 (54)	29 3/4 (756)	33 1/2 (851)	33 (838)	33 3/4 (857)		201 (91)
32, 34, 35, 36, 37	7 (178)	7 1/4 (184)	2 1/8 (54)	32 1/4 (820)	36 (914)	35 1/2 (902)	36 (914)		222 (101)
42, 44, 45, 46, 47	7 (178)	8 (203)	2 7/16 (62)	36 1/2 (925)	42 (1067)	41 (1041)	41 3/4 (1060)		265 (120)
56, 57	7 3/4 (197)	8 3/4 (222)	2 7/16 (65)	37 1/4 (947)	42 3/4 (1086)	41 3/4 (1060)	42 1/2 (1080)		290 (132)

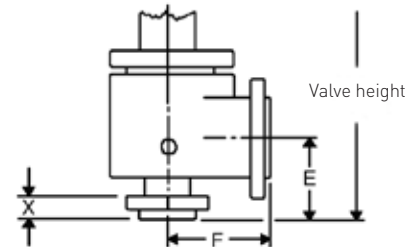

- Type J (Threaded Cap)
- Type C (Regular Lifting Lever) Also JOS-H-E
- Type D (Packed Lifting Lever)
- Type L (Bolted Cap)

# CROSBY J-SERIES

## DIRECT SPRING PRESSURE RELIEF VALVES

PRESSURE/TEMPERATURE LIMIT CHART  
 M Orifice, 3.60 sq.in. (2323 sq.mm) API effective area

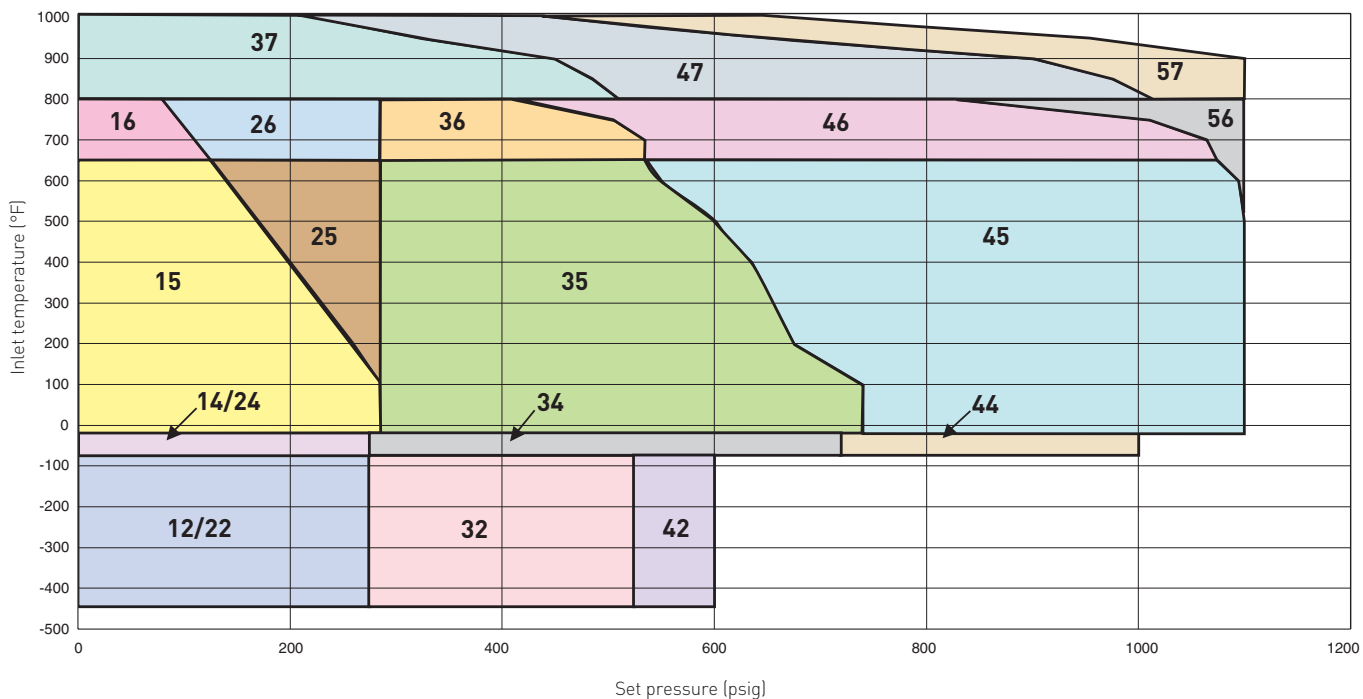

# CROSBY J-SERIES

## DIRECT SPRING PRESSURE RELIEF VALVES

### SIZES AND PRESSURE/TEMPERATURE LIMITS

#### N ORIFICE, 4.34 sq.in. (2800 sq.mm) API EFFECTIVE AREA

Valve series	Valve size		Standard connections ANSI		Maximum set pressure psig (barg)					Back press. limit at 100°F psig (38°C barg)		
	Inlet X	Outlet X	flanges raised face		Inlet					JOS <sup>[2]</sup>	JBS <sup>[2]</sup>	
			Inlet	Outlet	-450°F to -76°F (-268°C to -60°C)	-75°F to -21°F (-59°C to -30°C)	-20°F to +100°F (-29°C to +38°C)	+650°F <sup>[1]</sup> (+343°C <sup>[1]</sup> )	+800°F (+427°C)			+1000°F (+538°C)
JOS-E-	15	4N6	150	150			285 (19.6)	125 (8.62)			285 (19.6)	80 (5.51)
JBS-E-	25	4N6	300	150			285 (19.6)	285 (19.6)			285 (19.6)	80 (5.51)
JLT-	35	4N6	300	150			740 (51.0)	535 (36.8)			285 (19.6)	160 (11.0)
JOS-H-E- <sup>[1]</sup>	45	4N6	600	150			1000 (68.9)	1000 (68.9)			285 (19.6)	160 (11.0)
JOS-E-	16	4N6	150	150				125 (8.62)	80 (5.51)		285 (19.6)	80 (5.51)
JBS-E-	26	4N6	300	150				285 (19.6)	285 (19.6)		285 (19.6)	80 (5.51)
JLT-	36	4N6	300	150				535 (36.8)	410 (28.2)		285 (19.6)	160 (11.0)
	46	4N6	600	150				1000 (68.9)	825 (56.8)		285 (19.6)	160 (11.0)
JOS-E-	37	4N6	300	150					510 (35.1)	215 (14.8)	285 (19.6)	160 (11.0)
JBS-E-	47	4N6	600	150					1000 (68.9)	430 (29.6)	285 (19.6)	160 (11.0)
JLT-												
JOS-E-	14	4N6	150	150		275 (18.9)					275 (18.9)	80 (5.51)
JBS-E-	24	4N6	300	150		275 (18.9)					275 (18.9)	80 (5.51)
JLT-	34	4N6	300	150		720 (49.6)					275 (18.9)	160 (11.0)
	44	4N6	600	150		1000 (68.9)					275 (18.9)	160 (11.0)
JOS-E-	12	4N6	150	150	275 (18.9)						275 (18.9)	80 (5.51)
JBS-E-	22	4N6	300	150	275 (18.9)						275 (18.9)	80 (5.51)
JLT-	32	4N6	300	150	450 (31.0)						275 (18.9)	160 (11.0)
	42	4N6	600	150	500 (34.4)						275 (18.9)	160 (11.0)

#### NOTES

- Upper temperature limit of JOS-H-E-15, 25, 35 and 45 valves is +800°F (+427°C).
- Outlet pressure for temperatures above +100°F (+38°C) should not exceed the ANSI flange rating.
- Valves set below 15 psig (1.03 barg) cannot be stamped with the ASME Code Symbol. Only metal seated valves may be set below 15 psig.
- Series designations: JLTJOS-E and JLTJBS-E signify Series JOS-E, JBS-E with liquid trim for liquid and gas service.

#### LOW SET PRESSURE LIMITS

JOS-E	8 psig (0.55 barg)
JBS-E	10 psig (0.68 barg)
JLTJOS-E	15 psig (1.03 barg)
JLTJBS-E	25 psig (1.72 barg)

#### DIMENSIONS AND WEIGHTS

Valve series	Valve dimensions, inches (mm)								Approx. weight lbs (kg) type J
	Center to face		Use to find bolt length X	Approximate height Valve (cap) type					
	Inlet E	Outlet F		A and G	J and L	C	D		
<b>JOS-E-, JBS-E-, JLT-, JOS-H-E-</b>									
12, 14, 15, 16, 22, 24, 25, 26	7¼ (197)	8¼ (210)	2½ (54)	37¼ (959)	43¼ (1099)	42¼ (1073)	43 (1092)	260 (118)	
32, 34, 35, 36, 37	7¼ (197)	8¼ (210)	2½ (54)	37¼ (959)	43¼ (1099)	42¼ (1073)	43 (1092)	280 (127)	
42, 44, 45, 46, 47	7¼ (197)	8¾ (222)	2½ (60)	37¼ (959)	43¼ (1099)	42¼ (1073)	43 (1092)	297 (135)	

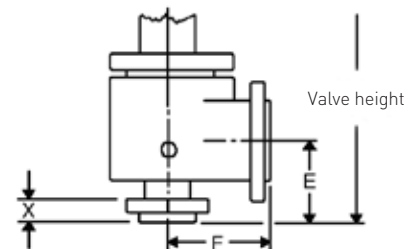

- Type J (Threaded Cap)
- Type C (Regular Lifting Lever) Also JOS-H-E
- Type D (Packed Lifting Lever)
- Type L (Bolted Cap)



# CROSBY J-SERIES

## DIRECT SPRING PRESSURE RELIEF VALVES

PRESSURE/TEMPERATURE LIMIT CHART  
 N Orifice, 4.34 sq.in. (2800 sq.mm) API effective area

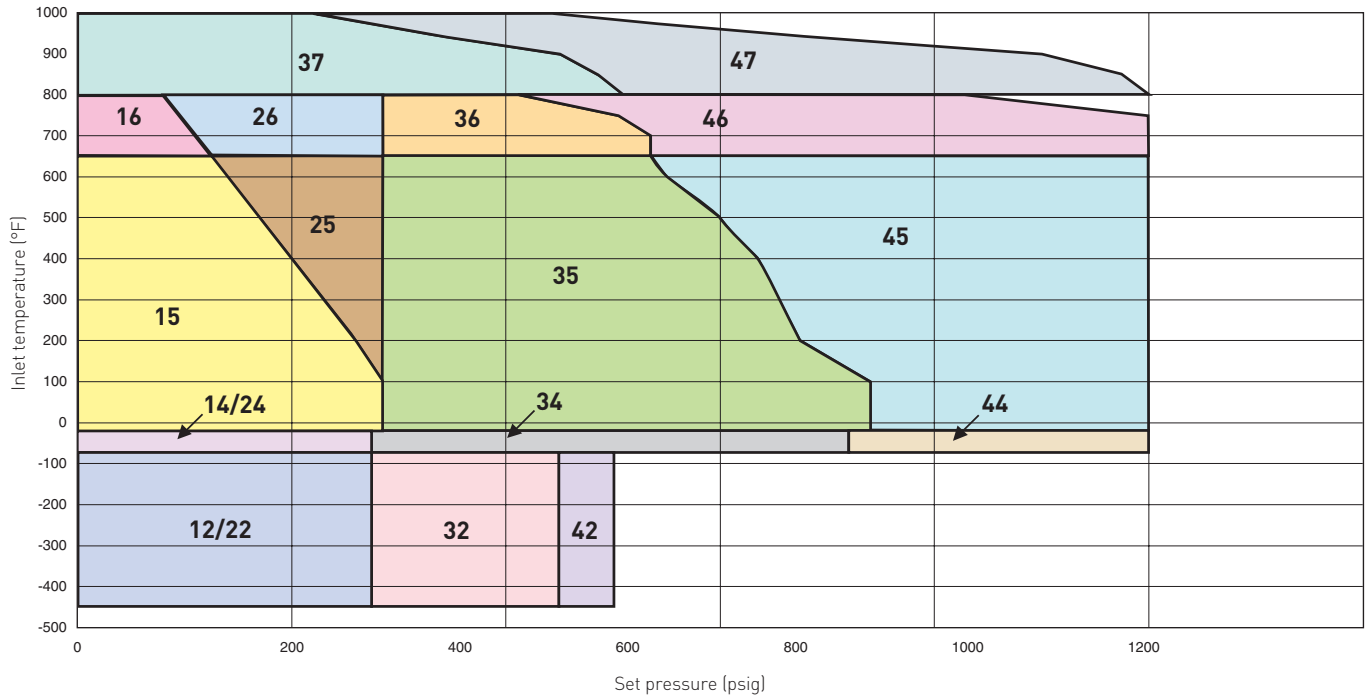

# CROSBY J-SERIES

## DIRECT SPRING PRESSURE RELIEF VALVES

### SIZES AND PRESSURE/TEMPERATURE LIMITS

#### P ORIFICE, 6.38 sq.in. (4116 sq.mm) API EFFECTIVE AREA

Valve series	Valve size		Standard connections ANSI		Maximum set pressure psig (barg)					Back press. limit at 100°F psig (38°C barg)		
	Inlet X	Orifice X	flanges raised face		Inlet					JOS <sup>[2]</sup>	JBS <sup>[2]</sup>	
	Outlet	Inlet	Outlet	-450°F to -76°F (-268°C to -60°C)	-75°F to -21°F (-59°C to -30°C)	-20°F to +100°F (-29°C to +38°C)	+650°F <sup>[1]</sup> (+343°C <sup>[1]</sup> )	+800°F (+427°C)	+1000°F (+538°C)			
JOS-E-	15	4P6	150	150			285 (19.6)	125 (8.6)			285 (19.6)	80 (5.51)
JBS-E-	25	4P6	300	150			285 (19.6)	285 (19.6)			285 (19.6)	80 (5.51)
JLT-	35	4P6	300	150			525 (36.2)	525 (36.2)			285 (19.6)	150 (10.3)
JOS-H-E- <sup>[1]</sup>	45	4P6	600	150			1000 (68.9)	1000 (68.9)			285 (19.6)	150 (10.3)
	55	4P6	900	150			1000 (68.9)	1000 (68.9)			285 (19.6)	150 (10.3)
JOS-E-	16	4P6	150	150				125 (8.6)	80 (5.5)		285 (19.6)	80 (5.51)
JBS-E-	26	4P6	300	150				285 (19.6)	285 (19.6)		285 (19.6)	80 (5.51)
JLT-	36	4P6	300	150				525 (36.2)	410 (28.3)		285 (19.6)	150 (10.3)
	46	4P6	600	150				1000 (68.9)	825 (56.9)		285 (19.6)	150 (10.3)
	56	4P6	900	150				1000 (68.9)	1000 (68.9)		285 (19.6)	150 (10.3)
JOS-E-	37	4P6	300	150					510 (35.1)	215 (14.8)	285 (19.6)	150 (10.3)
JBS-E-	47	4P6	600	150					1000 (68.9)	430 (29.6)	285 (19.6)	150 (10.3)
JLT-	57	4P6	900	150					1000 (68.9)	650 (44.8)	285 (19.6)	150 (10.3)
JOS-E-	14	4P6	150	150		275 (19.0)					275 (18.9)	80 (5.51)
JBS-E-	24	4P6	300	150		275 (19.0)					275 (18.9)	80 (5.51)
JLT-	34	4P6	300	150		525 (36.2)					275 (18.9)	150 (10.3)
	44	4P6	600	150		1000 (68.9)					275 (18.9)	150 (10.3)
JOS-E-	12	4P6	150	150	175 (12.1)						275 (18.9)	80 (5.51)
JBS-E-	22	4P6	300	150	175 (12.1)						275 (18.9)	80 (5.51)
JLT-	32	4P6	300	150	300 (20.7)						275 (18.9)	150 (10.3)
	42	4P6	600	150	480 (33.1)						275 (18.9)	150 (10.3)

#### NOTES

- Upper temperature limit of JOS-H-E-15, 25, 35, 45 and 55 valves is +800°F (+427°C).
- Outlet pressure for temperatures above +100°F (+38°C) should not exceed the ANSI flange rating.
- Valves set below 15 psig (1.03 barg) cannot be stamped with the ASME Code Symbol. Only metal seated valves may be set below 15 psig.
- Series designations: JLTJOS-E and JLTJBS-E signify Series JOS-E, JBS-E with liquid trim for liquid and gas service.

#### LOW SET PRESSURE LIMITS

JOS-E	7 psig (0.48 barg)
JBS-E	8 psig (0.55 barg)
JLTJOS-E	15 psig (1.03 barg)
JLTJBS-E	25 psig (1.72 barg)

#### DIMENSIONS AND WEIGHTS

Valve series	Valve dimensions, inches (mm)							Approx. weight lbs (kg) type J
	Center to face		Use to find bolt length X	Approximate height Valve (cap) type				
	Inlet E	Outlet F		A and G	J and L	C	D	
<b>JOS-E-, JBS-E-, JLT-, JOS-H-E-</b>								
12, 14, 15, 16,	7 <sup>1</sup> / <sub>8</sub>	9	2 <sup>1</sup> / <sub>8</sub>	37	42 <sup>1</sup> / <sub>2</sub>	41 <sup>1</sup> / <sub>2</sub>	42 <sup>1</sup> / <sub>4</sub>	270
22, 24, 25, 26	(181)	(229)	(54)	(940)	(1080)	(1054)	(1073)	(122)
32, 34, 35,	8 <sup>7</sup> / <sub>8</sub>	10	2 <sup>1</sup> / <sub>8</sub>	38 <sup>3</sup> / <sub>4</sub>	44 <sup>1</sup> / <sub>4</sub>	43 <sup>1</sup> / <sub>4</sub>	44	286
36, 37	(225)	(254)	(54)	(984)	(1124)	(1099)	(1118)	(130)
42, 44, 45,	8 <sup>7</sup> / <sub>8</sub>	10	2 <sup>3</sup> / <sub>16</sub>	41	46 <sup>1</sup> / <sub>2</sub>	45 <sup>1</sup> / <sub>2</sub>	46 <sup>1</sup> / <sub>4</sub>	401
46, 47	(225)	(254)	(65)	(1041)	(1181)	(1156)	(1175)	(182)
55, 56, 57	8 <sup>7</sup> / <sub>8</sub>	10	2 <sup>3</sup> / <sub>16</sub>	41	46 <sup>1</sup> / <sub>2</sub>	45 <sup>1</sup> / <sub>2</sub>	46 <sup>1</sup> / <sub>4</sub>	416
	(225)	(254)	(67)	(1041)	(1181)	(1156)	(1175)	(189)

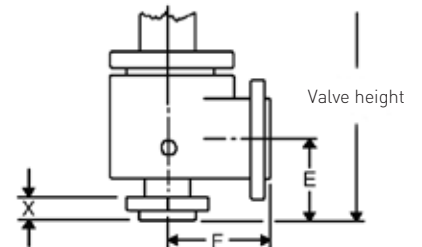

- Type J (Threaded Cap)
- Type C (Regular Lifting Lever) Also JOS-H-E
- Type D (Packed Lifting Lever)
- Type L (Bolted Cap)

**CROSBY J-SERIES**  
 DIRECT SPRING PRESSURE RELIEF VALVES

PRESSURE/TEMPERATURE LIMIT CHART  
 P Orifice, 6.38 sq.in. (4116 sq.mm) API effective area

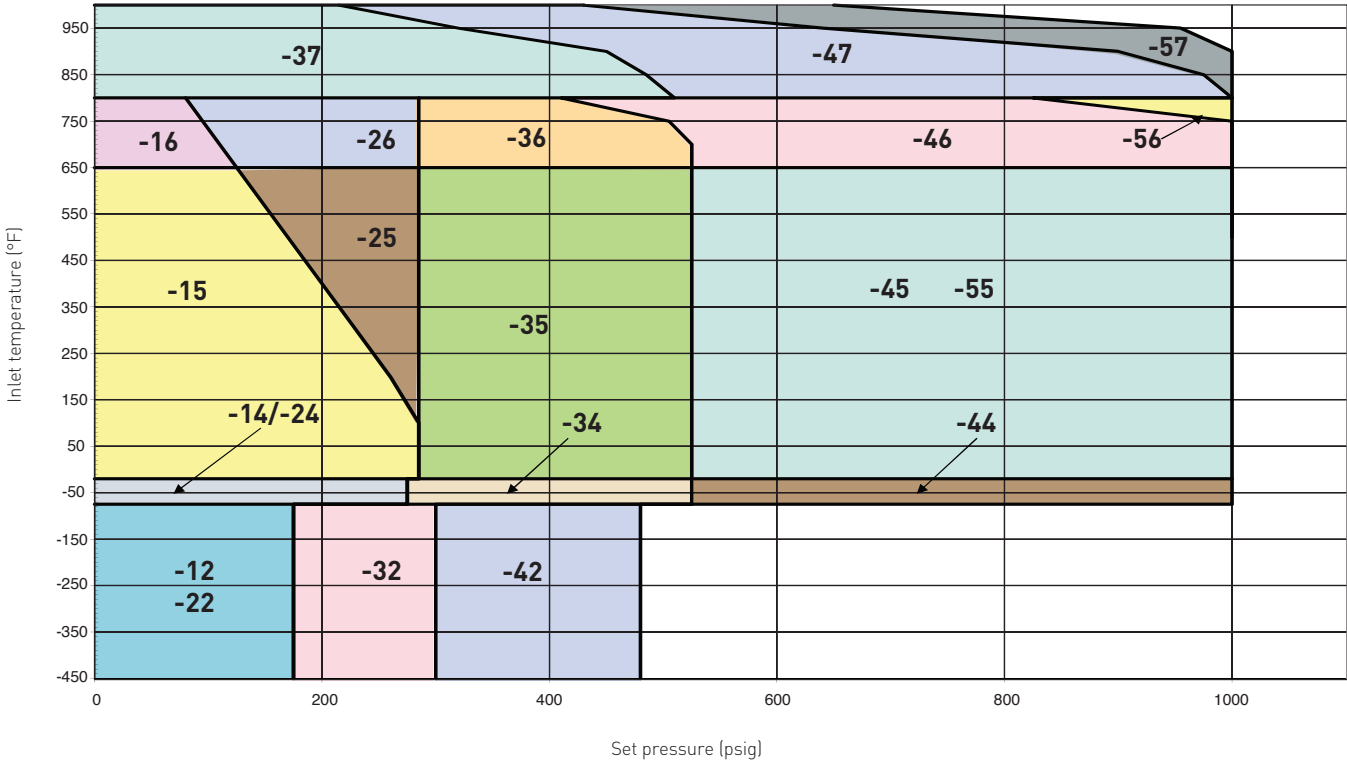

# CROSBY J-SERIES

## DIRECT SPRING PRESSURE RELIEF VALVES

### SIZES AND PRESSURE/TEMPERATURE LIMITS

#### Q ORIFICE, 11.05 sq.in. (7129 sq.mm) API EFFECTIVE AREA

Valve series	Valve size		Standard connections ANSI		Maximum set pressure psig (barg)						Back press. limit at 100°F psig (38°C barg)	
	Inlet X Orifice X Outlet	Inlet	Outlet	Inlet						JOS <sup>[2]</sup>	JBS <sup>[2]</sup>	
				-450°F to -76°F (-268°C to -60°C)	-75°F to -21°F (-59°C to -30°C)	-20°F to +100°F (-29°C to +38°C)	+650°F <sup>[1]</sup> (+343°C <sup>[1]</sup> )	+800°F (+427°C)	+1000°F (+538°C)			
JOS-E-	15	6Q8	150	150			165 (11.3)	125 (8.62)			115 (7.92)	70 (4.82)
JBS-E-	25	6Q8	300	150			165 (11.3)	165 (11.3)			115 (7.92)	70 (4.82)
JLT-	35	6Q8	300	150			300 (20.6)	300 (20.6)			115 (7.92)	115 (7.92)
JOS-H-E- <sup>[1]</sup>	45	6Q8	600	150			600 (41.3)	600 (41.3)			115 (7.92)	115 (7.92)
		6Q8 (HP)	600	150			1000 (68.9)	1000 (68.9)			115 (7.92)	115 (7.92)
JOS-E-	16	6Q8	150	150				125 (8.62)	80 (5.51)		115 (7.92)	70 (4.82)
JBS-E-	26	6Q8	300	150				165 (11.3)	165 (11.3)		115 (7.92)	70 (4.82)
JLT-	36	6Q8	300	150				300 (20.6)	300 (20.6)		115 (7.92)	115 (7.92)
	46	6Q8	600	150				600 (41.3)	600 (41.3)		115 (7.92)	115 (7.92)
		6Q8 (HP)	600	150				1000 (68.9)	825 (56.9)		115 (7.92)	115 (7.92)
JOS-E-	37	6Q8	300	150					165 (11.3)	165 (11.3)	115 (7.92)	115 (7.92)
JBS-E-	47	6Q8	600	150					600 (41.3)	430 (29.6)	115 (7.92)	115 (7.92)
JLT-		6Q8 (HP)	600	150					1000 (68.9)	430 (29.6)	115 (7.92)	115 (7.92)
JOS-E-	14	6Q8	150	150		165 (11.3)					115 (7.92)	70 (4.82)
JBS-E-	24	6Q8	300	150		165 (11.3)					115 (7.92)	70 (4.82)
JLT-	34	6Q8	300	150		300 (20.6)					115 (7.92)	115 (7.92)
	44	6Q8	600	150		600 (41.3)					115 (7.92)	115 (7.92)
		6Q8 (HP)	600	150		1000 (68.9)					115 (7.92)	115 (7.92)
JOS-E-	12	6Q8	150	150	165 (11.3)						115 (7.92)	70 (4.82)
JBS-E-	22	6Q8	300	150	165 (11.3)						115 (7.92)	70 (4.82)
JLT-	32	6Q8	300	150	250 (17.2)						115 (7.92)	115 (7.92)
	42	6Q8	600	150	300 (20.6)						115 (7.92)	115 (7.92)
		6Q8 (HP)	600	150	561 (38.7)						115 (7.92)	115 (7.92)
JOS-HP-E	42	6Q8	600	150	561 (38.7)						115 (7.92)	115 (7.92)
JBS-HP-E	44	6Q8	600	150		1000 (68.9)					115 (7.92)	115 (7.92)
	45	6Q8	600	150			1000 (68.9)	1000 (68.9)			115 (7.92)	115 (7.92)
	46	6Q8	600	150			1000 (68.9)	825 (56.9)			115 (7.92)	115 (7.92)
	47	6Q8	600	150				1000 (68.9)	430 (29.6)		115 (7.92)	115 (7.92)

#### NOTES

- Upper temperature limit of JOS-H-E-15, 25, 35 and 45 valves is +800°F (+427°C).
- Outlet pressure for temperatures above +100°F (+38°C) should not exceed the ANSI flange rating.
- Valves set below 15 psig (1.03 barg) cannot be stamped with the ASME Code Symbol. Only metal seated valves may be set below 15 psig.
- Series designations: JLTJOS-E and JLTJBS-E signify Series JOS-E, JBS-E with liquid trim for liquid and gas service.

#### LOW SET PRESSURE LIMITS

JOS-E	7 psig (0.48 barg)
JBS-E	8 psig (0.55 barg)
JLTJOS-E	15 psig (1.03 barg)
JLTJBS-E	25 psig (1.72 barg)

#### DIMENSIONS AND WEIGHTS

Valve series	Valve dimensions, inches (mm)							Approx. weight lbs (kg) type J
	Center to face		Use to find bolt length X	Approximate height				
	Inlet E	Outlet F		Valve (cap) type				
			A and G	J and L	C	D		
<b>JOS-E-, JBS-E-, JLT-, JOS-H-E-</b>								
12, 14, 15, 16,	9 <sup>7</sup> / <sub>16</sub>	9 <sup>1</sup> / <sub>2</sub>	2 <sup>5</sup> / <sub>16</sub>	4 <sup>2</sup> / <sub>4</sub>	4 <sup>7</sup> / <sub>4</sub>	4 <sup>6</sup> / <sub>4</sub>	4 <sup>7</sup> / <sub>2</sub>	481
22, 24, 25, 26	[240]	[241]	[59]	[1073]	[1213]	[1187]	[1207]	[218]
32, 34, 35,	9 <sup>7</sup> / <sub>16</sub>	9 <sup>1</sup> / <sub>2</sub>	2 <sup>5</sup> / <sub>16</sub>	4 <sup>2</sup> / <sub>4</sub>	4 <sup>7</sup> / <sub>4</sub>	4 <sup>6</sup> / <sub>4</sub>	4 <sup>7</sup> / <sub>2</sub>	492
36, 37	[240]	[241]	[59]	[1073]	[1213]	[1187]	[1207]	[223]
42, 44, 45,	9 <sup>7</sup> / <sub>16</sub>	9 <sup>1</sup> / <sub>2</sub>	2 <sup>5</sup> / <sub>16</sub>	4 <sup>6</sup> / <sub>4</sub>	5 <sup>1</sup> / <sub>4</sub>	5 <sup>0</sup> / <sub>4</sub>	5 <sup>1</sup> / <sub>2</sub>	565
46, 47	[240]	[241]	[75]	[1175]	[1314]	[1289]	[1308]	[256]
<b>JOS-HP-E-, JBS-HP-E-</b>								
42, 44, 45,	9 <sup>7</sup> / <sub>16</sub>	9 <sup>1</sup> / <sub>2</sub>	2 <sup>5</sup> / <sub>16</sub>	4 <sup>9</sup> / <sub>4</sub>	5 <sup>4</sup> / <sub>4</sub>	5 <sup>3</sup> / <sub>4</sub>	5 <sup>4</sup> / <sub>2</sub>	585
46, 47	[240]	[241]	[75]	[1251]	[1391]	[1340]	[1384]	[265]

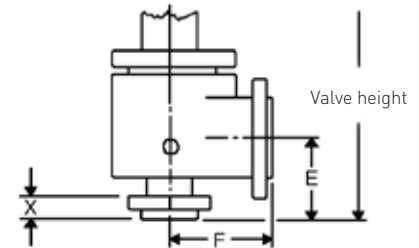

- Type J (Threaded Cap)
- Type C (Regular Lifting Lever) Also JOS-H-E
- Type D (Packed Lifting Lever)
- Type L (Bolted Cap)

**CROSBY J-SERIES**  
 DIRECT SPRING PRESSURE RELIEF VALVES

PRESSURE/TEMPERATURE LIMIT CHART  
 Q Orifice, 11.05 sq.in. (7129 sq.mm) API effective area

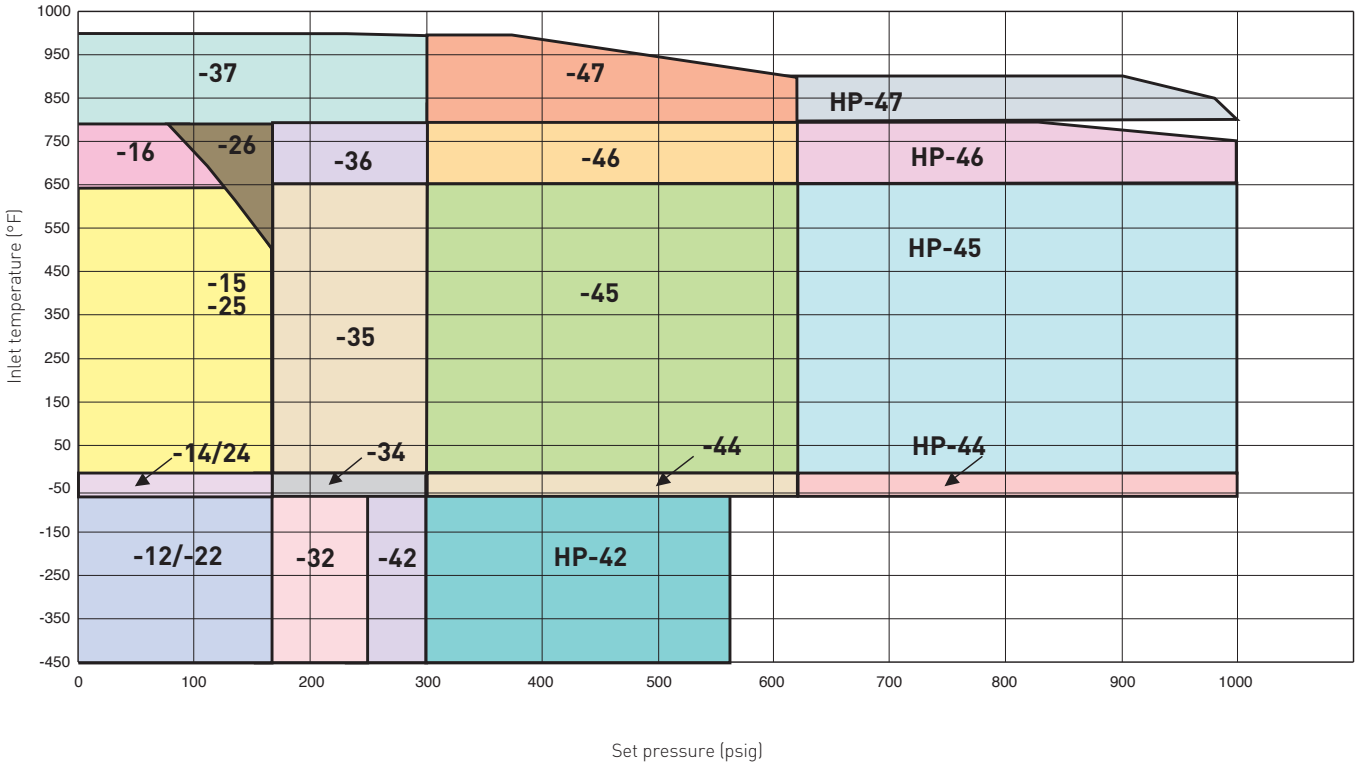

# CROSBY J-SERIES

## DIRECT SPRING PRESSURE RELIEF VALVES

### SIZES AND PRESSURE/TEMPERATURE LIMITS

#### R ORIFICE, 16.0 sq.in. (10323 sq.mm) API EFFECTIVE AREA

Valve series	Valve size		Standard connections ANSI		Maximum set pressure psig (barg)						Back press. limit at 100°F psig (38°C barg)	
	Inlet X Orifice X Outlet	Inlet	Outlet	Inlet						JOS <sup>[2]</sup>	JBS <sup>[2]</sup>	
				-450°F to -76°F (-268°C to -60°C)	-75°F to -21°F (-59°C to -30°C)	-20°F to +100°F (-29°C to +38°C)	+650°F <sup>[1]</sup> (+343°C <sup>[1]</sup> )	+800°F (+427°C)	+1000°F (+538°C)			
JOS-E-	15	6R8	150	150			100 (6.89)	100 (6.89)			60 (4.13)	50 (3.44)
JBS-E-	25	6R8	300	150			100 (6.89)	100 (6.89)			60 (4.13)	50 (3.44)
JLT-	35	6R10	300	150			230 (15.8)	230 (15.8)			100 (6.89)	100 (6.89)
JOS-H-E- <sup>[1]</sup>	45	6R10	600	150			300 (20.6)	300 (20.6)			100 (6.89)	100 (6.89)
		6R10 (HP)	600	150			850 (58.6)	850 (58.6)			100 (6.89)	100 (6.89)
JOS-E-	16	6R8	150	150				100 (6.89)	80 (5.51)		60 (4.13)	40 (2.75)
JBS-E-	26	6R8	300	150				100 (6.89)	100 (6.89)		60 (4.13)	50 (3.44)
JLT-	36	6R10	300	150				230 (15.8)	230 (15.8)		100 (6.89)	100 (6.89)
		6R10 (HP)	600	150				300 (20.6)	300 (20.6)		100 (6.89)	100 (6.89)
JOS-E-	37	6R8	300	150					100 (6.89)	100 (6.89)	60 (4.13)	50 (4.13)
JBS-E-	47	6R10	600	150					300 (20.6)	300 (20.6)	100 (6.89)	100 (6.89)
JLT-		6R10 (HP)	600	150					850 (58.6)	430 (29.65)	100 (6.89)	100 (6.89)
JOS-E-	14	6R8	150	150		100 (6.89)					60 (4.13)	50 (3.44)
JBS-E-	24	6R8	300	150		100 (6.89)					60 (4.13)	50 (3.44)
JLT-	34	6R10	300	150		230 (15.8)					100 (6.89)	100 (6.89)
		6R10 (HP)	600	150		300 (20.6)					100 (6.89)	100 (6.89)
JOS-E-	12	6R8	150	150	55 (3.79)						37 (2.55)	27.5 (1.89)
JBS-E-	22	6R8	300	150	55 (3.79)						37 (2.55)	27.5 (1.89)
JLT-	32	6R10	300	150	150 (10.3)						100 (6.89)	75 (5.17)
		6R10 (HP)	600	150	200 (13.7)						100 (6.89)	100 (6.89)
JOS-HP-E	42	6R10	600	150	395 (27.2)						100 (6.89)	100 (6.89)
JBS-HP-E	44	6R10	600	150		850 (58.6)					100 (6.89)	100 (6.89)
		6R10	600	150			850 (58.6)	850 (58.6)			100 (6.89)	100 (6.89)
		6R10	600	150				850 (58.6)	825 (56.9)		100 (6.89)	100 (6.89)
		6R10	600	150					850 (58.6)	430 (29.6)	100 (6.89)	100 (6.89)

#### NOTES

- Upper temperature limit of JOS-H-E-15, 25, 35 and 45 valves is +800°F (+427°C).
- Outlet pressure for temperatures above +100°F (+38°C) should not exceed the ANSI flange rating.
- Valves set below 15 psig (1.03 barg) cannot be stamped with the ASME Code Symbol. Only metal seated valves may be set below 15 psig.
- Series designations: JLTJOS-E and JLTJBS-E signify Series JOS-E, JBS-E with liquid trim for liquid and gas service.

#### LOW SET PRESSURE LIMITS

JOS-E	8 psig (0.55 barg)
JBS-E	8 psig (0.55 barg)
JLTJOS-E	15 psig (1.03 barg)
JLTJBS-E	25 psig (1.72 barg)

#### DIMENSIONS AND WEIGHTS

Valve series	Valve dimensions, inches (mm)							Approx. weight lbs (kg) type J
	Center to face		Use to find bolt length X	Approximate height Valve (cap) type				
	Inlet E	Outlet F		A and G	J and L	C	D	
<b>JOS-E-, JBS-E-, JLT-, JOS-H-E-</b>								
12, 14, 15, 16,	9 <sup>7</sup> / <sub>16</sub>	9 <sup>1</sup> / <sub>2</sub>	2 <sup>5</sup> / <sub>16</sub>	4 <sup>7</sup> / <sub>4</sub>	5 <sup>3</sup> / <sub>4</sub>	5 <sup>2</sup> / <sub>2</sub>	5 <sup>3</sup> / <sub>4</sub>	564
22, 24, 25, 26, 37	[240]	[241]	[59]	[1213]	[1353]	[1334]	[1353]	[256]
32, 34, 35, 36	9 <sup>7</sup> / <sub>16</sub>	10 <sup>1</sup> / <sub>2</sub>	2 <sup>5</sup> / <sub>16</sub>	4 <sup>7</sup> / <sub>4</sub>	5 <sup>3</sup> / <sub>4</sub>	5 <sup>2</sup> / <sub>2</sub>	5 <sup>3</sup> / <sub>4</sub>	602
	[240]	[267]	[59]	[1213]	[1353]	[1334]	[1353]	[273]
42, 44, 45,	9 <sup>7</sup> / <sub>16</sub>	10 <sup>1</sup> / <sub>2</sub>	2 <sup>3</sup> / <sub>4</sub>	4 <sup>7</sup> / <sub>4</sub>	5 <sup>3</sup> / <sub>4</sub>	5 <sup>2</sup> / <sub>2</sub>	5 <sup>3</sup> / <sub>4</sub>	631
46, 47	[240]	[267]	[70]	[1213]	[1353]	[1334]	[1353]	[286]
<b>JOS-HP-E, JBS-HP-E</b>								
42, 44, 45,	9 <sup>7</sup> / <sub>16</sub>	10 <sup>1</sup> / <sub>2</sub>	2 <sup>5</sup> / <sub>16</sub>	5 <sup>0</sup> / <sub>8</sub>	5 <sup>6</sup> / <sub>8</sub>	5 <sup>5</sup> / <sub>8</sub>	5 <sup>6</sup> / <sub>8</sub>	831
46, 47	[240]	[267]	[75]	[1292]	[1432]	[1407]	[1426]	[377]

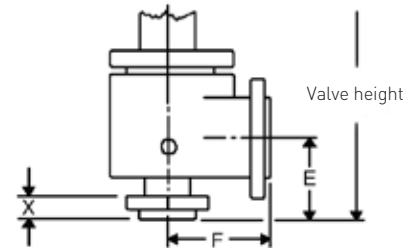

- Type J (Threaded Cap)
- Type C (Regular Lifting Lever) Also JOS-H-E
- Type D (Packed Lifting Lever)
- Type L (Bolted Cap)

# CROSBY J-SERIES

## DIRECT SPRING PRESSURE RELIEF VALVES

PRESSURE/TEMPERATURE LIMIT CHART  
 R Orifice, 16.0 sq.in. (10,323 sq.mm) API Effective Area

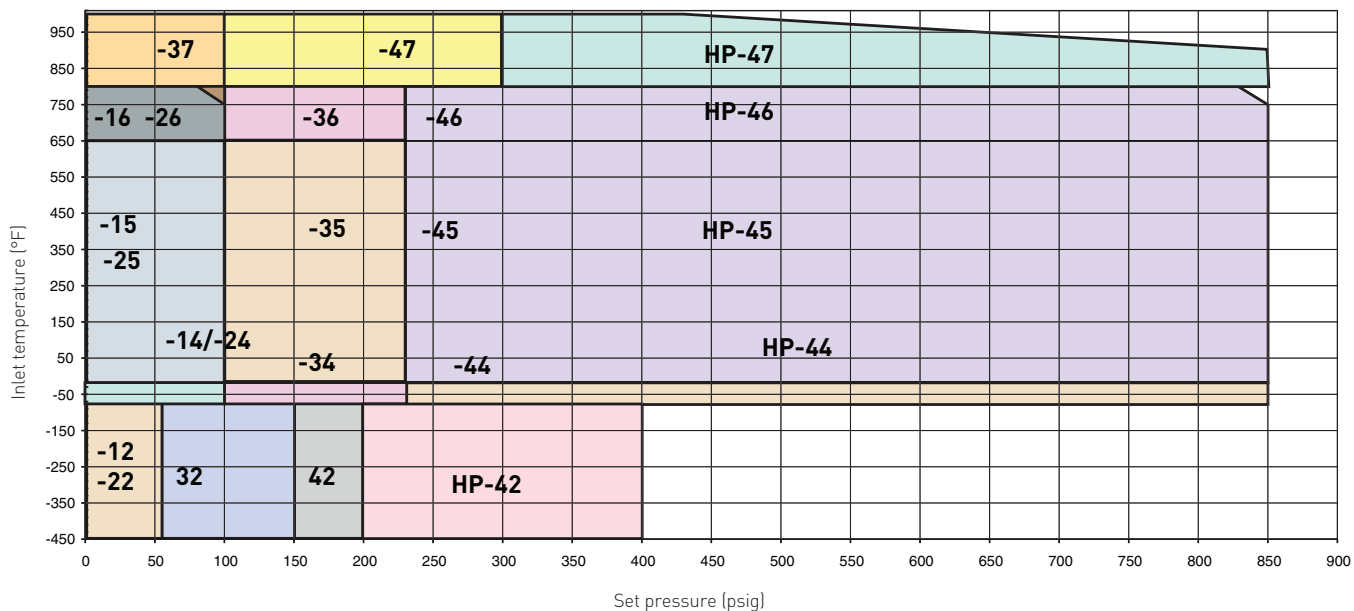

# CROSBY J-SERIES

## DIRECT SPRING PRESSURE RELIEF VALVES

### SIZES AND PRESSURE/TEMPERATURE LIMITS

#### T ORIFICE, 26.0 sq.in. (16774 sq.mm) API EFFECTIVE AREA

Valve series	Valve size		Standard connections ANSI		Maximum set pressure psig (barg)					Back press. limit at 100°F psig (38°C barg)		
	Inlet X	Orifice X	flanges raised face		Inlet					JOS <sup>[2]</sup>	JBS <sup>[2]</sup>	
	Outlet	Inlet	Outlet	-450°F to -76°F (-268°C to -60°C)	-75°F to -21°F (-59°C to -30°C)	-20°F to +100°F (-29°C to +38°C)	+650°F <sup>[1]</sup> (+343°C <sup>[1]</sup> )	+800°F (+427°C)	+1000°F (+538°C)			
JOS-E-	15	8T10	150	150			65 (4.48)	65 (4.48)			30 (2.06)	30 (2.06)
JBS-E-	25	8T10	300	150			65 (4.48)	65 (4.48)			30 (2.06)	30 (2.06)
JLT-	35	8T10	300	150			120 (8.27)	120 (8.27)			60 (4.13)	60 (4.13)
JOS-H-E- <sup>[1]</sup>	45	8T10	300	150			300 (20.6)	300 (20.6)			100 (6.89)	100 (6.89)
JOS-E-	16	8T10	150	150				65 (4.48)	65 (4.48)		30 (2.06)	30 (2.06)
JBS-E-	26	8T10	300	150				65 (4.48)	65 (4.48)		30 (2.06)	30 (2.06)
JLT-	36	8T10	300	150				120 (8.27)	120 (8.27)		60 (4.13)	60 (4.13)
	46	8T10	300	150				300 (20.6)	300 (20.6)		100 (6.89)	100 (6.89)
JOS-E-	37	8T10	300	150					300 (20.6)	215 (14.8)	60 (4.13)	60 (4.13)
JBS-E-												
JLT-												
JOS-E-	14	8T10	150	150		65 (4.48)					30 (2.06)	30 (2.06)
JBS-E-	24	8T10	300	150		65 (4.48)					30 (2.06)	30 (2.06)
JLT-	34	8T10	300	150		120 (8.27)					60 (4.13)	60 (4.13)
JOS-E-	12	8T10	150	150	50 (3.44)						30 (2.06)	25 (1.72)
JBS-E-	22	8T10	300	150	50 (3.44)						30 (2.06)	25 (1.72)
JLT-	32	8T10	300	150	65 (4.48)						45 (3.10)	32.5 (2.24)

#### NOTES

- Upper temperature limit of JOS-H-E-15, 25, 35 and 45 valves is +800°F (+427°C).
- Outlet pressure for temperatures above +100°F (+38°C) should not exceed the ANSI flange rating.
- Valves set below 15 psig (1.03 barg) cannot be stamped with the ASME Code Symbol. Only metal seated valves may be set below 15 psig.
- Series designations: JLTJOS-E and JLTJBS-E signify Series JOS-E, JBS-E with liquid trim for liquid and gas service.

#### LOW SET PRESSURE LIMITS

JOS-E	8 psig (0.55 barg)
JBS-E	8 psig (0.55 barg)
JLTJOS-E	15 psig (1.03 barg)
JLTJBS-E	25 psig (1.72 barg)

#### DIMENSIONS AND WEIGHTS

Valve series	Valve dimensions, inches (mm)								Approx. weight lbs (kg) type J
	Center to face		Use to find bolt length X	Approximate height Valve (cap) type					
	Inlet E	Outlet F		A and G	J and L	C	D		
<b>JOS-E-, JBS-E-, JLT-, JOS-H-E-</b>									
12, 14, 15, 16,	10 <sup>7</sup> / <sub>8</sub>	11	2 <sup>9</sup> / <sub>16</sub>	54	59 <sup>1</sup> / <sub>2</sub>	58 <sup>1</sup> / <sub>2</sub>	59 <sup>1</sup> / <sub>4</sub>	882	
22, 24, 25, 26	(276)	(279)	(65)	(1372)	(1511)	(1486)	(1505)	(400)	
32, 34, 35,	10 <sup>7</sup> / <sub>8</sub>	11	2 <sup>9</sup> / <sub>16</sub>	54	59 <sup>1</sup> / <sub>2</sub>	58 <sup>1</sup> / <sub>2</sub>	59 <sup>1</sup> / <sub>4</sub>	902	
36, 37	(276)	(279)	(65)	(1372)	(1511)	(1486)	(1505)	(409)	
45, 46	10 <sup>7</sup> / <sub>8</sub>	11	2 <sup>9</sup> / <sub>16</sub>	54	59 <sup>1</sup> / <sub>2</sub>	58 <sup>1</sup> / <sub>2</sub>	59 <sup>1</sup> / <sub>4</sub>	930	
	(276)	(279)	(65)	(1372)	(1511)	(1486)	(1505)	(422)	

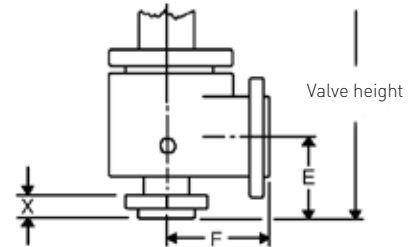

- Type J (Threaded Cap)
- Type C (Regular Lifting Lever) Also JOS-H-E
- Type D (Packed Lifting Lever)
- Type L (Bolted Cap)



# CROSBY J-SERIES

## DIRECT SPRING PRESSURE RELIEF VALVES

PRESSURE/TEMPERATURE LIMIT CHART  
 T Orifice, 26.0 sq.in. (16,774 sq.mm) API effective area

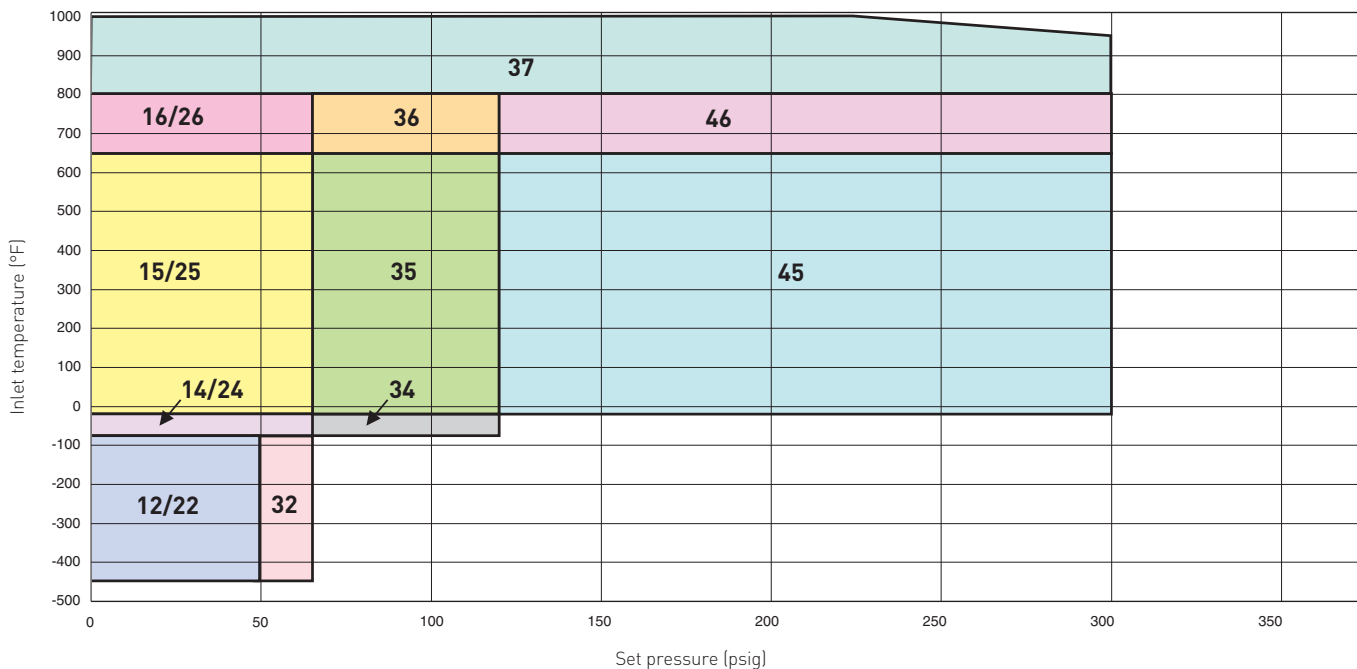

# CROSBY J-SERIES

## DIRECT SPRING PRESSURE RELIEF VALVES

### SIZES AND PRESSURE/TEMPERATURE LIMITS

#### T2 ORIFICE, 27.872 sq.in. (17981 sq.mm) API EFFECTIVE AREA

Valve series	Valve size		Standard connections ANSI		Maximum set pressure psig (barg)						Back press. limit at 100°F psig (38°C barg)	
	Inlet X	Orifice X	flanges raised face		Inlet						JOS <sup>[2]</sup>	JBS <sup>[2]</sup>
	Outlet	Inlet	Outlet	-450°F to -76°F (-268°C to -60°C)	-75°F to -21°F (-59°C to -30°C)	-20°F to +100°F (-29°C to +38°C)	+650°F <sup>[1]</sup> (+343°C <sup>[1]</sup> )	+800°F (+427°C)	+1000°F (+538°C)			
JOS-E-	15	8T210	150	150			65 (4.48)	65 (4.48)			30 (2.06)	30 (2.06)
JBS-E-	25	8T210	300	150			65 (4.48)	65 (4.48)			30 (2.06)	30 (2.06)
JOS-H-E- <sup>[1]</sup>	35	8T210	300	150			120 (8.27)	120 (8.27)			60 (4.13)	60 (4.13)
	45	8T210	300	150			300 (20.6)	300 (20.6)			100 (6.89)	100 (6.89)
JOS-E-	16	8T210	150	150				65 (4.48)	65 (4.48)		30 (2.06)	30 (2.06)
JBS-E-	26	8T210	300	150				65 (4.48)	65 (4.48)		30 (2.06)	30 (2.06)
	36	8T210	300	150				120 (8.27)	120 (8.27)		60 (4.13)	60 (4.13)
	46	8T210	300	150				300 (20.6)	300 (20.6)		100 (6.89)	100 (6.89)
JOS-E-	37	8T210	300	150					300 (20.6)	215 (14.8)	60 (4.13)	60 (4.13)
JBS-E-												
JOS-E-	14	8T210	150	150		65 (4.48)					30 (2.06)	30 (2.06)
JBS-E-	24	8T210	300	150		65 (4.48)					30 (2.06)	30 (2.06)
	34	8T210	300	150		120 (8.27)					60 (4.13)	60 (4.13)
JOS-E-	12	8T210	150	150	50 (3.44)						30 (2.06)	25 (1.72)
JBS-E-	22	8T210	300	150	50 (3.44)						30 (2.06)	25 (1.72)
	32	8T210	300	150	65 (4.48)						45 (3.10)	32.5 (2.24)

#### NOTES

- Upper temperature limit of JOS-H-E-15, 25, 35 and 45 valves is +800°F (+427°C).
- Outlet pressure for temperatures above +100°F (+38°C) should not exceed the ANSI flange rating.
- Valves set below 15 psig (1.03 barg) cannot be stamped with the ASME Code Symbol. Only metal seated valves may be set below 15 psig.

#### LOW SET PRESSURE LIMITS

JOS-E	8 psig (0.55 barg)
JBS-E	8 psig (0.55 barg)

#### DIMENSIONS AND WEIGHTS

Valve series	Valve dimensions, inches (mm)								Approx. height lbs (kg) type J
	Center to face		Use to find bolt length X	Approximate height Valve (cap) type					
	Inlet E	Outlet F		A and G	J and L	C	D		
<b>JOS-E-, JBS-E-, JOS-H-E-</b>									
12, 14, 15, 16,	10 <sup>7</sup> / <sub>16</sub>	11	2 <sup>9</sup> / <sub>16</sub>	54	59 <sup>1</sup> / <sub>2</sub>	58 <sup>1</sup> / <sub>2</sub>	59 <sup>1</sup> / <sub>4</sub>	882	
22, 24, 25, 26	(276)	(279)	(65)	(1372)	(1511)	(1486)	(1505)	(400)	
32, 34, 35,	10 <sup>7</sup> / <sub>16</sub>	11	2 <sup>9</sup> / <sub>16</sub>	54	59 <sup>1</sup> / <sub>2</sub>	58 <sup>1</sup> / <sub>2</sub>	59 <sup>1</sup> / <sub>4</sub>	902	
36, 37	(276)	(279)	(65)	(1372)	(1511)	(1486)	(1505)	(409)	
45, 46	10 <sup>7</sup> / <sub>16</sub>	11	2 <sup>9</sup> / <sub>16</sub>	54	59 <sup>1</sup> / <sub>2</sub>	58 <sup>1</sup> / <sub>2</sub>	59 <sup>1</sup> / <sub>4</sub>	930	
	(276)	(279)	(65)	(1372)	(1511)	(1486)	(1505)	(422)	

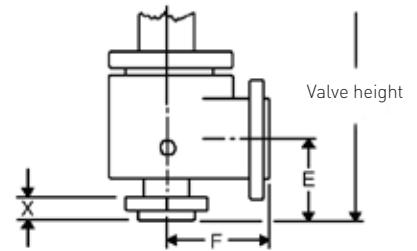

- Type J (Threaded Cap)
- Type C (Regular Lifting Lever) Also JOS-H-E
- Type D (Packed Lifting Lever)
- Type L (Bolted Cap)

# CROSBY J-SERIES

## DIRECT SPRING PRESSURE RELIEF VALVES

PRESSURE/TEMPERATURE LIMIT CHART  
 T2 Orifice, 27.872 sq.in. (17,981 sq.mm) API effective area

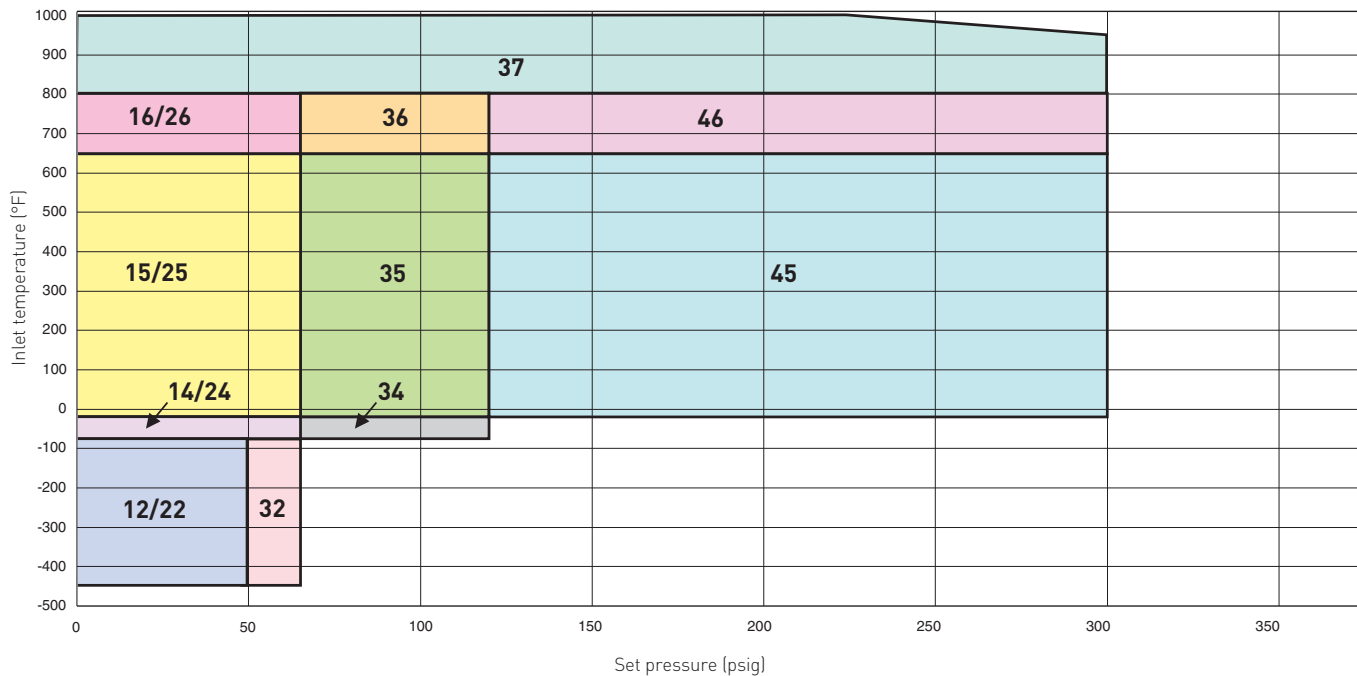

# CROSBY J-SERIES

## DIRECT SPRING PRESSURE RELIEF VALVES

### SIZES AND PRESSURE/TEMPERATURE LIMITS

#### V ORIFICE, 42.19 sq.in. (27218 sq.mm) API EFFECTIVE AREA

Valve series	Valve size		Standard connections ANSI		Maximum set pressure psig (barg)						Back press. limit at 100°F psig (38°C barg)	
	Inlet X	Orifice X	flanges raised face		Inlet						JOS <sup>[2]</sup>	JBS <sup>[2]</sup>
	Outlet	Inlet	Outlet	-450°F to -76°F (-268°C to -60°C)	-75°F to -21°F (-59°C to -30°C)	-20°F to +100°F (-29°C to +38°C)	+650°F <sup>[1]</sup> (+343°C <sup>[1]</sup> )	+800°F (+427°C)	+1000°F (+538°C)			
JOS-E-	15	10V14	150	150			100 (6.9)	100 (6.9)			60 (4.1)	60 (4.1)
JBS-E-	25	10V14	300	150			100 (6.9)	100 (6.9)			60 (4.1)	60 (4.1)
JOS-H-E- <sup>[1]</sup>	35	10V14	300	150			316 (21.8)	230 (15.9)			120 (8.3)	120 (8.3)
JOS-E-	16	10V14	150	150				100 (6.9)	80		60 (4.1)	60 (4.1)
JBS-E-	26	10V14	300	150				100 (6.9)	100		60 (4.1)	60 (4.1)
	36	10V14	300	150 (120)				230 (15.9)	230		120 (8.3)	120 (8.3)
JOS-E	37	10V14	300	150					100	100 (6.9)	60 (4.1)	60 (4.1)
JBS-E												
JOS-E-	14	10V14	150	150		100 (6.9)					60 (4.1)	60 (4.1)
JBS-E-	24	10V14	300	150 (60)		100 (6.9)					60 (4.1)	60 (4.1)
	34	10V14	300	150		316 (21.8)					120 (8.3)	120 (8.3)
JOS-E-	12	10V14	150	150	70 (4.8)						60 (4.1)	42 (2.9)
JBS-E-	22	10V14	300	150 (42)	70 (4.8)						60 (4.1)	42 (2.9)
	32	10V14	300	150	70 (4.8)						60 (4.1)	42 (2.9)

#### NOTES

- Upper temperature limit of JOS-H-E-15, 25, 35 and 45 valves is +800°F (+427°C).
- Outlet pressure for temperatures above +100°F (+38°C) should not exceed the ANSI flange rating.
- Valves set below 15 psig (1.03 barg) cannot be stamped with the ASME Code Symbol. Only metal seated valves may be set below 15 psig.

#### LOW SET PRESSURE LIMITS

JOS-E	13 psig (0.89 barg)
JBS-E	13 psig (0.89 barg)

#### DIMENSIONS AND WEIGHTS

Valve series	Valve dimensions, inches (mm)						Approx. weight lbs (kg) type J
	Center to face		Use to find bolt length X	Approximate height Valve (cap) type			
	Inlet E	Outlet F		J and L	C	D	
<b>JOS-E-, JBS-E-, JOS-H-E-</b>							
12, 14, 15, 16,	12 (305)	16 (406)	2.93 (74)	75.2 (1910)	75.2 (1910)	75.2 (1910)	2175 (918)
22, 24, 25, 26, 32,	12 (305)	16 (406)	2.93 (74)	75.2 (1910)	75.2 (1910)	75.2 (1910)	2248 (930)
34, 35, 36, 37							

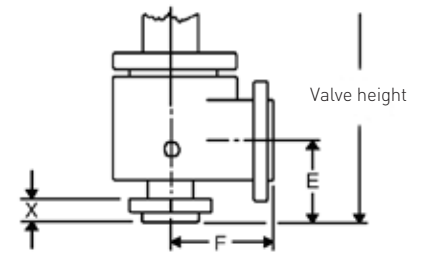

- Type J (Threaded Cap)
- Type C (Regular Lifting Lever) Also JOS-H-E
- Type D (Packed Lifting Lever)
- Type L (Bolted Cap)

# CROSBY J-SERIES

## DIRECT SPRING PRESSURE RELIEF VALVES

PRESSURE/TEMPERATURE LIMIT CHART  
 V Orifice, 42.19 sq.in. (27,218 sq.mm) API effective area

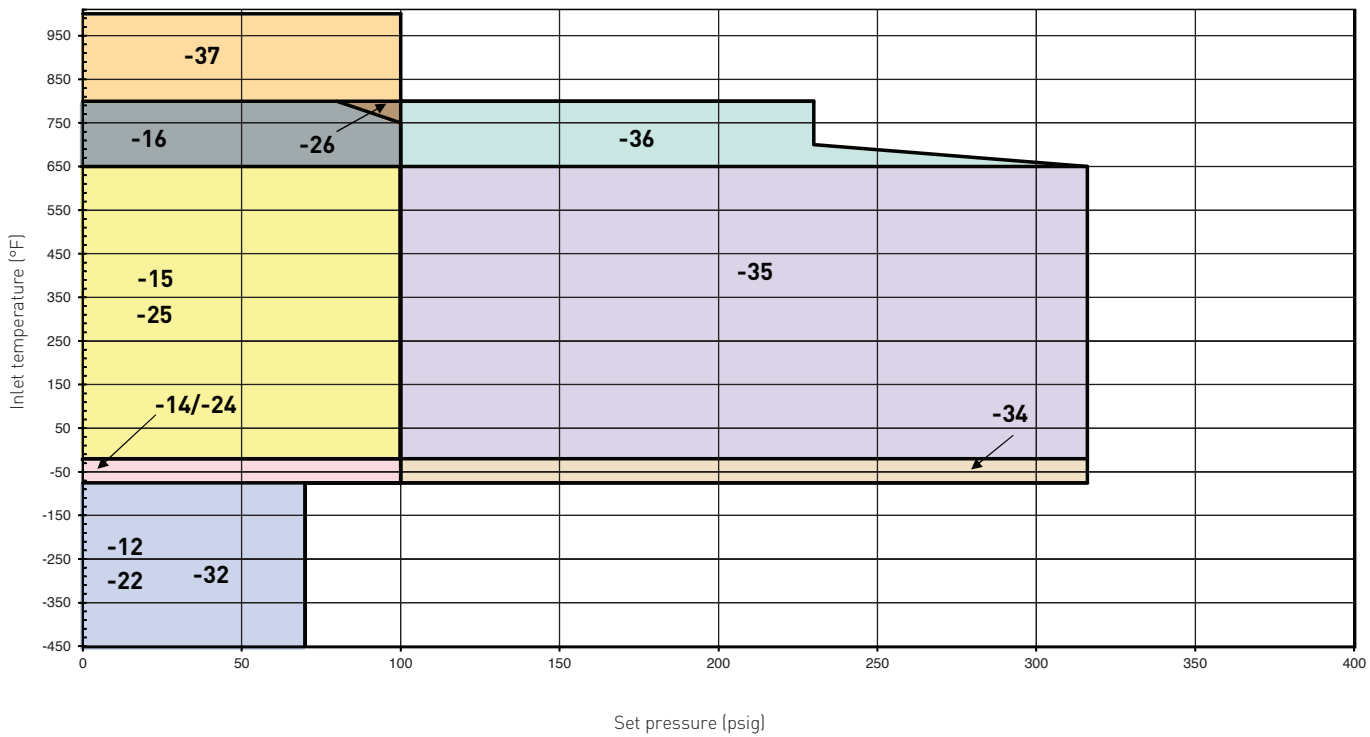

# CROSBY J-SERIES

## DIRECT SPRING PRESSURE RELIEF VALVES

### SIZES AND PRESSURE/TEMPERATURE LIMITS

#### W ORIFICE, 60.75 sq.in. (39193 sq.mm) API EFFECTIVE AREA

Valve series	Valve size		Standard connections ANSI		Maximum set pressure psig (barg)						Back press. limit at 100°F psig (38°C barg)	
	Inlet X	Outlet X	flanges raised face		Inlet						JOS <sup>[2]</sup>	JBS <sup>[2]</sup>
			Inlet	Outlet	-450°F to -76°F [-268°C to -60°C]	-75°F to -21°F [-59°C to -30°C]	-20°F to +100°F [-29°C to +38°C]	+650°F <sup>[1]</sup> [+343°C <sup>[1]</sup> ]	+800°F [+427°C]	+1000°F [+538°C]		
JOS-E-	15	12W16	150	150			100 (6.9)	100 (6.9)			60 (4.1)	60 (4.1)
JBS-E-	25	12W16	300	150			100 (6.9)	100 (6.9)			60 (4.1)	60 (4.1)
JOS-H-E- <sup>[1]</sup>	35	12W16	300	150			316 (21.8)	230 (15.9)			120 (8.3)	175 (12.1)
JOS-E-	16	12W16	150	150				100 (6.9)	80 (5.5)		60 (4.1)	60 (4.1)
JBS-E-	26	12W16	300	150				100 (6.9)	100 (6.9)		60 (4.1)	60 (4.1)
	36	12W16	300	150				230 (15.9)	230 (15.9)		120 (8.3)	175 (12.1)
JOS-E	37	12W16	300	150					100 (6.9)	100 (6.9)	60 (4.1)	60 (4.1)
JBS-E												
JOS-E-	14	12W16	150	150		100 (6.9)					60 (4.1)	60 (4.1)
JBS-E-	24	12W16	300	150		100 (6.9)					60 (4.1)	60 (4.1)
	34	12W16	300	150		316 (21.8)					120 (8.3)	175 (12.1)
JOS-E-	12	12W16	150	150	70 (4.8)						60 (4.1)	42 (2.9)
JBS-E-	22	12W16	300	150	70 (4.8)						60 (4.1)	42 (2.9)
	32	12W16	300	150	154 (10.6)						120 (4.1)	80 (2.9)

#### NOTES

- Upper temperature limit of JOS-H-E-15, 25, 35 and 45 valves is +800°F (+427°C).
- Outlet pressure for temperatures above +100°F (+38°C) should not exceed the ANSI flange rating.
- Valves set below 15 psig (1.03 barg) cannot be stamped with the ASME Code Symbol. Only metal seated valves may be set below 15 psig.

#### LOW SET PRESSURE LIMITS

JOS-E	15 psig (1.03 barg)
JBS-E	15 psig (1.03 barg)

#### DIMENSIONS AND WEIGHTS

Valve series	Valve dimensions, inches (mm)						Approx. weight lbs (kg) type J
	Center to face		Use to find bolt length X	Approximate height Valve (cap) type			
	Inlet E	Outlet F		J and L	C	D	
<b>JOS-E-, JBS-E-, JOS-H-E-</b>							
12, 14, 15, 16	14 (356)	16 (406)	3.2 (81)	88 (2235)	88 (2235)	88 (2235)	3340 1515
22, 24, 25, 26, 32,	14 (356)	16 (406)	3.2 (81)	88 (2235)	88 (2235)	88 (2235)	3400 1542
34, 35, 36, 37							

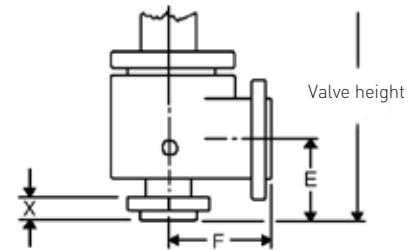

- Type J (Threaded Cap)
- Type C (Regular Lifting Lever) Also JOS-H-E
- Type D (Packed Lifting Lever)
- Type L (Bolted Cap)

# CROSBY J-SERIES

## DIRECT SPRING PRESSURE RELIEF VALVES

PRESSURE/TEMPERATURE LIMIT CHART  
 W Orifice, 60.75 sq.in. (39193 sq.mm) API effective area

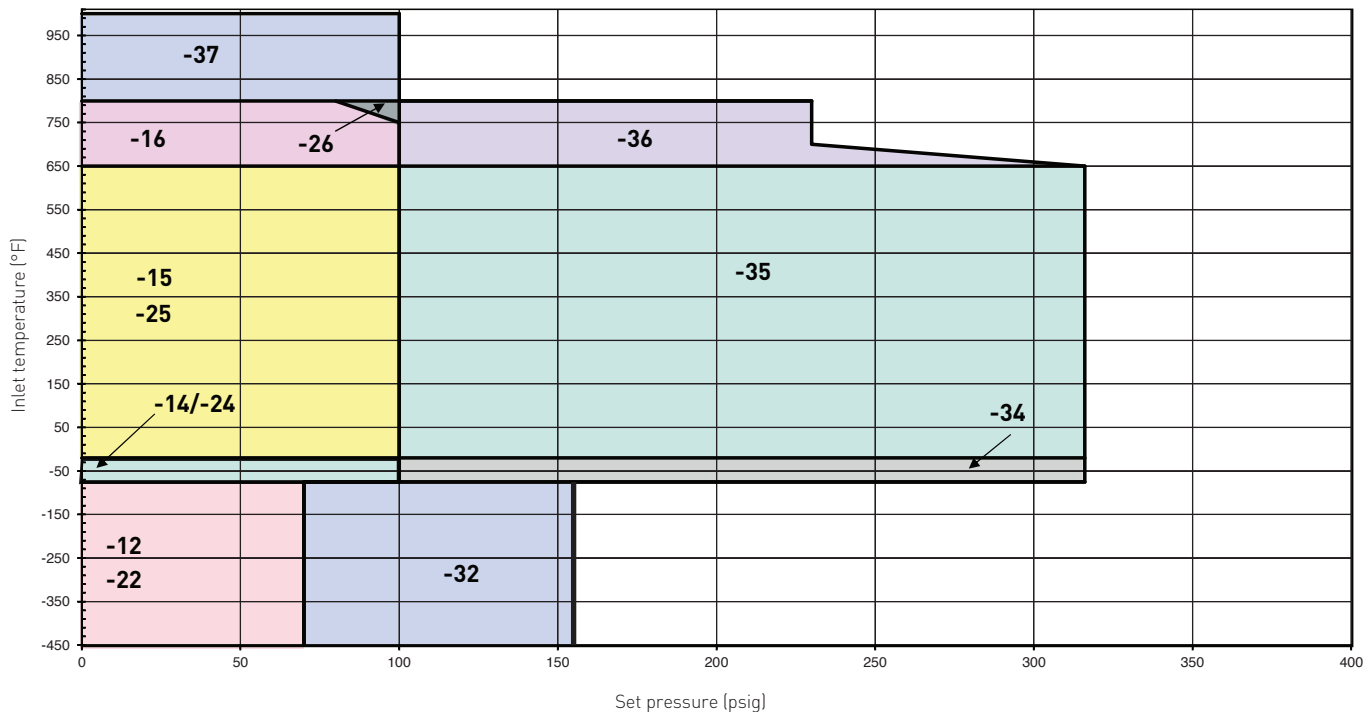

**CROSBY J-SERIES**  
 DIRECT SPRING PRESSURE RELIEF VALVES

**AIR CAPACITIES - Series JOS-E, JBS-E, JLTJOS-E AND JLTJBS-E, USCS Units<sup>(1)</sup> (United States Customary System) Set pressures 5 - 880 psig**

Set pressure (psig)	Orifice letter designation and effective area, sq.in.																
	D	E	F	G	H	J	K	L	M	N	P	Q	R	T	T2	V	W
<b>1 psi incr.</b>	<b>2.2</b>	<b>3.9</b>	<b>6.1</b>	<b>9.9</b>	<b>15.5</b>	<b>25.3</b>	<b>36.2</b>	<b>56.2</b>	<b>70.9</b>	<b>85.5</b>	<b>126</b>	<b>218</b>	<b>315</b>	<b>512</b>	<b>549</b>	<b>835</b>	<b>1362</b>
<b>5 psi incr.</b>	<b>10.8</b>	<b>19.3</b>	<b>30.3</b>	<b>49.5</b>	<b>77.4</b>	<b>127</b>	<b>181</b>	<b>281</b>	<b>355</b>	<b>427</b>	<b>628</b>	<b>1088</b>	<b>1575</b>	<b>2560</b>	<b>2744</b>	<b>4173</b>	<b>6810</b>
5			<b>124</b>	<b>204</b>	<b>319</b>	<b>522</b>	<b>747</b>					<b>4489</b>					
6			<b>130</b>	<b>213</b>	<b>333</b>	<b>546</b>	<b>780</b>	<b>1210</b>				<b>4686</b>					
7			<b>135</b>	<b>222</b>	<b>347</b>	<b>569</b>	<b>813</b>	<b>1261</b>			<b>2821</b>	4884					
8		<b>90.2</b>	<b>141</b>	<b>231</b>	<b>361</b>	<b>592</b>	<b>845</b>	1312	<b>1656</b>	<b>1996</b>	2936	5082	7361	11964	12824		
9		<b>93.7</b>	<b>146</b>	<b>240</b>	<b>375</b>	615	878	1363	<b>1720</b>	<b>2074</b>	3050	5280	7648	12429	13323		
10	<b>54.6</b>	<b>97.2</b>	152	<b>249</b>	389	638	911	1414	1785	2152	3164	5477	7934	12895	13822		
15	64.5	114.0	179	294	459	753	1076	1670	2107	2540	3735	6466	9366	15222	16317	24807	40487
20	74.3	132.0	207	339	530	868	1240	1925	2429	2929	4307	7455	10798	17550	18812	28600	46677
30	94.0	167.0	262	429	670	1098	1570	2436	3074	3706	5449	9433	13663	22205	23802	36187	59059
40	115.0	206.0	322	528	825	1352	1932	2997	3783	4560	6706	11608	16814	27326	29291	44532	72678
50	137.0	244.0	383	627	980	1605	2294	3559	4492	5415	7962	13783	19965	32447	34780	52877	86298
60	159.0	283.0	444	726	1135	1859	2656	4121	5201	6270	9219	15959	23116	37567	40269	61222	99917
70	180.0	321.0	504	825	1289	2112	3018	4683	5910	7124	10476	18134	26266	42688	45758	69567	113537
80	202.0	360.0	565	923	1444	2366	3380	5245	6619	7979	11732	20309	29417	47809	51247	77912	127157
90	224.0	399.0	625	1022	1599	2619	3742	5807	7328	8834	12989	22485	32568	52930	56736	86257	140776
100	245.0	437.0	686	1121	1753	2872	4104	6368	8037	9688	14246	24660	35719	58051	62225	94603	154396
120	289.0	515.0	807	1319	2063	3379	4829	7492	9455	11397	16759	29011	42021	68292	73203	111293	181635
140	332.0	592.0	928	1517	2372	3886	5553	8616	10873	13107	19273	33362	48323	78534	84181	127983	208874
160	376.0	669.0	1049	1715	2682	4393	6277	9739	12291	14816	21786	37712	54624	88775	95158	144673	236113
180	419.0	746.0	1170	1913	2991	4900	7001	10863	13709	16525	24299	42063	60926	99017	106136	161363	263352
200	462.0	823.0	1291	2111	3300	5407	7725	11986	15127	18235	26813	46414	67228	109258	117114	178054	290591
220	506.0	901.0	1412	2309	3610	5914	8449	13110	16545	19944	29326	50764	73530	119500	128092	194744	317830
240	549.0	978.0	1533	2507	3919	6421	9174	14234	17963	21653	31840	55115	79832	129741	139070	211434	345069
260	593.0	1055.0	1654	2705	4229	6927	9898	15357	19381	23363	34353	59466	86133	139983	150048	228124	372308
280	636.0	1132.0	1775	2903	4538	7434	10622	16481	20799	25072	36866	63817	92435	150225	161026	244814	399547
300	679.0	1210.0	1896	3101	4848	7941	11346	17604	22217	26781	39380	68167	98737	160466	172004	261505	426786
320	723.0	1287.0	2017	3299	5157	8448	12070	18728	23635	28491	41893	72518	105039				
340	766.0	1364.0	2138	3497	5466	8955	12795	19852	25054	30200	44406	76869	111340				
360	810.0	1441.0	2259	3695	5776	9462	13519	20975	26472	31909	46920	81220	117642				
380	853.0	1519.0	2380	3892	6085	9969	14243	22099	27890	33619	49433	85570	123944				
400	896.0	1596.0	2501	4090	6395	10475	14967	23222	29308	35328	51947	89921	130246				
420	940.0	1673.0	2622	4288	6704	10982	15691	24346	30726	37037	54460	94272	136548				
440	983.0	1750.0	2743	4486	7013	11489	16416	25470	32144	38746	56973	98622	142849				
460	1027.0	1827.0	2864	4684	7323	11996	17140	26593	33562	40456	59487	102973	149151				
480	1070.0	1905.0	2986	4882	7632	12503	17864	27717	34980	42165	62000	107324	155453				

\* Numbers marked bold = JOS-E only.

**NOTES**

1. For air capacities, USCS units are exact equivalents of Imperial units.
2. Not valid below 30 psig set pressure.
3. Capacities below 30 psig set pressure are calculated at 3 psi overpressure.

\* Capacity in standard cubic feet per minute of air at 60°F and 10% overpressure. Valve discharging to atmospheric pressure.

Capacities at 15 psig and above are certified by the National Board of Boiler and Pressure Vessel Inspectors and in accordance with the ASME Boiler and Pressure Vessel Code, Section VIII.



# CROSBY J-SERIES

## DIRECT SPRING PRESSURE RELIEF VALVES

### AIR CAPACITIES - Series JOS-E, JBS-E, JLTJOS-E AND JLTJBS-E, USCS Units<sup>(1)</sup> (United States Customary System) Set pressures 5 - 880 psig (Continued)

Set pressure (psig)	Orifice letter designation and effective area, sq.in.																
	D	E	F	G	H	J	K	L	M	N	P	Q	R	T	T2	V	W
<b>1 psi incr.</b>	<b>2.2</b>	<b>3.9</b>	<b>6.1</b>	<b>9.9</b>	<b>15.5</b>	<b>25.3</b>	<b>36.2</b>	<b>56.2</b>	<b>70.9</b>	<b>85.5</b>	<b>126</b>	<b>218</b>	<b>315</b>	<b>512</b>	<b>549</b>	<b>835</b>	<b>1362</b>
<b>5 psi incr.</b>	<b>10.8</b>	<b>19.3</b>	<b>30.3</b>	<b>49.5</b>	<b>77.4</b>	<b>127</b>	<b>181</b>	<b>281</b>	<b>355</b>	<b>427</b>	<b>628</b>	<b>1088</b>	<b>1575</b>	<b>2560</b>	<b>2744</b>	<b>4173</b>	<b>6810</b>
500	1113	1982	3107	5080	7942	13010	18588	28841	36398	43874	64514	111675	161755				
520	1157	2059	3228	5278	8251	13517	19312	29964	37816	45584	67027	116025	168056				
540	1200	2136	3349	5476	8561	14023	20037	31088	39234	47293	69540	120376	174358				
560	1244	2214	3470	5674	8870	14530	20761	32211	40652	49002	72054	124727	180660				
580	1287	2291	3591	5872	9179	15037	21485	33335	42070	50712	74567	129077	186962				
600	1330	2368	3712	6070	9489	15544	22209	34459	43488	52421	77080	133428	193263				
620	1374	2445	3833	6268	9798	16051	22933	35582	44906	54130	79594	137779	199565				
640	1417	2523	3954	6466	10108	16558	23657	36706	46324	55840	82107	142130	205867				
660	1461	2600	4075	6663	10417	17065	24382	37829	47742	57549	84621	146480	212169				
680	1504	2677	4196	6861	10727	17572	25106	38953	49160	59258	87134	150831	218471				
700	1547	2754	4317	7059	11036	18078	25830	40077	50578	60968	89647	155182	224772				
720	1591	2831	4438	7257	11345	18585	26554	41200	51996	62677	92161	159532	231074				
740	1634	2909	4559	7455	11655	19092	27278	42324	53414	64386	94674	163883	237376				
760	1678	2986	4680	7653	11964	19599	28003	43447	54832	66095	97188	168234	243678				
780	1721	3063	4801	7851	12274	20106	28727	44571	56250	67805	99701	172585	249979				
800	1764	3140	4922	8049	12583	20613	29451	45695	57668	69514	102214	176935	256281				
820	1808	3218	5043	8247	12892	21120	30175	46818	59086	71223	104728	181286	262583				
840	1851	3295	5164	8445	13202	21626	30899	47942	60504	72933	107241	185637	268885				
860	1895	3372	5285	8643	13511	22133	31624	49066	61922	74642	109754	189987					
880	1938	3449	5406	8841	13821	22640	32348	50189	63340	76351	112268	194338					

#### NOTES

1. For air capacities, USCS units are exact equivalents of Imperial units.
2. Not valid below 30 psig set pressure.
3. Capacities below 30 psig set pressure are calculated at 3 psi overpressure.

\* Capacity in standard cubic feet per minute of air at 60°F and 10% overpressure. Valve discharging to atmospheric pressure.

Capacities at 15 psig and above are certified by the National Board of Boiler and Pressure Vessel Inspectors and in accordance with the ASME Boiler and Pressure Vessel Code, Section VIII.

**CROSBY J-SERIES**  
**DIRECT SPRING PRESSURE RELIEF VALVES**

**AIR CAPACITIES - Series JOS-E, JBS-E, JLTJOS-E AND JLTJBS-E, USCS Units<sup>(1)</sup> (United States Customary System) Set pressures 900 - 6000 psig**

Set pressure (psig)	Orifice letter designation and effective area, sq.in.														
	D	E	F	G	H	J	K	L	M	N	P	Q	R	T	T2
<b>1 psi incr.</b>	<b>2.2</b>	<b>3.9</b>	<b>6.1</b>	<b>9.9</b>	<b>15.5</b>	<b>25.3</b>	<b>36.2</b>	<b>56.2</b>	<b>70.9</b>	<b>85.5</b>	<b>126</b>	<b>218</b>	<b>315</b>	<b>512</b>	<b>549</b>
<b>5 psi incr.</b>	<b>10.8</b>	<b>19.3</b>	<b>30.3</b>	<b>49.5</b>	<b>77.4</b>	<b>127</b>	<b>181</b>	<b>281</b>	<b>355</b>	<b>427</b>	<b>628</b>	<b>1088</b>	<b>1575</b>	<b>2560</b>	<b>2744</b>
900	1981	3527	5528	9039	14130	23147	33072	51313	64758	78061	114781	198689			
920	2025	3604	5649	9237	14440	23654	33796	52436	66176	79770	117295	203040			
940	2068	3681	5770	9435	14749	24161	34520	53560	67594	81479	119808	207390			
960	2111	3758	5891	9632	15058	24668	35244	54684	69012	83189	122321	211741			
980	2155	3836	6012	9830	15368	25174	35969	55807	70430	84898	124835	216092			
1000	2198	3913	6133	10028	15677	25681	36693	56931	71849	86607	127348	220443			
1100	2415	4299	6738	11018	17224	28216	40314	62549	78939						
1200	2632	4685	7343	12008	18771	30750	43935	68167							
1300	2849	5071	7948	12997	20319	33284	47556	73785							
1400	3066	5457	8554	13987	21866	35819	51177	79403							
1480	3240	5766	9038	14779	23103	37846	54073	83897							
1500	3283	5844	9159	14977	23413	38353	54798								
1600	3500	6230	9764	15966	24960	40887	58419								
1700	3717	6616	10369	16956	26507	43422	62040								
1800	3934	7002	10975	17946	28054	45956	65660								
1900	4151	7388	11580	18935	29601	48490	69281								
2000	4368	7774	12185	19925	31148	51024	72902								
2100	4585	8161	12790	20915	32695	53559	76523								
2200	4802	8547	13396	21904	34242	56093	80144								
2300	5019	8933	14001	22894	35790	58627									
2400	5236	9319	14606	23883	37337	61162									
2500	5453	9705	15211	24873	38884	63696									
2600	5670	10091	15817	25863	40431	66230									
2700	5887	10478	16422	26852	41978	68765									
2800	6104	10864	17027	27842											
2900	6321	11250	17632	28832											
3000	6538	11636	18237	29821											
3100	6755	12022	18843	30811											
3200	6972	12408	19448	31801											
3300	7189	12795	20053	32790											
3400	7406	13181	20658	33780											
3500	7623	13567	21264	34770											
3600	7840	13953	21869	35759											
3700	8057	14339	22474	36749											
3800	8274	14725	23079												
3900	8491	15112	23685												
4000	8708	15498	24290												
4200	9142	16270	25500												
4400	9576	17042	26711												
4600	10009	17815	27921												
4800	10443	18587	29132												
5000	10877	19359	30342												
5200	11311	20132													
5500	11962	21290													
5600	12179	21676													
5800	12613	22449													
6000	13047	23221													

**NOTE**

1. For air capacities, USCS units are exact equivalents of Imperial units.

\* Capacity in standard cubic feet per minute of air at 60°F and 10% overpressure. Valve discharging to atmospheric pressure.

Capacities certified by the National Board of Boiler and Pressure Vessel Inspectors and in accordance with the ASME Boiler and Pressure Vessel Code, Section VIII.

# CROSBY J-SERIES

## DIRECT SPRING PRESSURE RELIEF VALVES

### WATER CAPACITIES - Series JLTJOS-E and JLTJBS-E, USCS Units<sup>[1]</sup> (United States Customary System) Differential pressures $\Delta P^{[2]}$ , 5 - 1040 psi<sup>[3]</sup>

Differential pressure $\Delta P$ - psi	Orifice letter designation and effective area, sq.in.													
	D	E	F	G	H	J	K	L	M	N	P	Q	R	T
5	6.9	12.3	19.3	31.6	49.4	81	116	180	227	273	402	695	1007	1636
10	9.8	17.5	27.4	44.7	69.9	115	164	254	320	386	568	983	1424	2314
15	12.0	21.4	33.5	54.8	85.6	140	200	311	392	473	696	1204	1744	2834
20	13.9	24.7	38.7	63.3	98.9	162	231	359	453	546	803	1390	2014	3273
40	19.6	34.9	54.7	89.5	140.0	229	327	508	641	773	1136	1966	2848	4629
60	24.0	42.7	67.0	110.0	171.0	281	401	622	785	946	1391	2408	3488	5669
80	27.7	49.4	77.4	127.0	198.0	324	463	718	906	1092	1606	2781	4028	6546
100	31.0	55.2	86.5	141.0	221.0	362	517	803	1013	1221	1796	3109	4503	7318
120	34.0	60.5	94.8	155.0	242.0	397	567	880	1110	1338	1967	3406	4933	8017
140	36.7	65.3	102.0	167.0	262.0	429	612	950	1199	1445	2125	3679	5328	8659
160	39.2	69.8	109.0	179.0	280.0	458	655	1016	1282	1545	2272	3933	5696	9257
180	41.6	74.0	116.0	190.0	297.0	486	694	1077	1359	1639	2410	4171	6042	9819
200	43.9	78.0	122.0	200.0	313.0	512	732	1135	1433	1727	2540	4397	6368	10350
220	46.0	81.9	128.0	210.0	328.0	537	768	1191	1503	1812	2664	4611	6679	10855
240	48.0	85.5	134.0	219.0	343.0	561	802	1244	1570	1892	2782	4816	6976	11338
260	50.0	89.0	139.0	228.0	357.0	584	834	1295	1634	1970	2896	5013	7261	11801
280	51.9	92.3	145.0	237.0	370.0	606	866	1344	1696	2044	3005	5202	7535	12246
300	53.7	95.6	150.0	245.0	383.0	627	896	1391	1755	2116	3111	5385	7800	12676
320	55.5	98.7	155.0	253.0	396.0	648	926	1436	1813	2185	3213	5561	8055	13092
340	57.2	102.0	159.0	261.0	408.0	668	954	1480	1868	2252	3312	5733	8303	13494
360	58.8	105.0	164.0	268.0	420.0	687	982	1523	1923	2318	3408	5899	8544	
380	60.4	108.0	169.0	276.0	431.0	706	1009	1565	1975	2381	3501	6060	8778	
400	62.0	110.0	173.0	283.0	442.0	724	1035	1606	2027	2443	3592	6218	9006	
420	63.6	113.0	177.0	290.0	453.0	742	1061	1645	2077	2503	3681	6371	9229	
440	65.0	116.0	181.0	297.0	464.0	760	1085	1684	2125	2562	3767	6521	9446	
460	66.5	118.0	186.0	303.0	474.0	777	1110	1722	2173	2620	3852	6668	9658	
480	67.9	121.0	190.0	310.0	484.0	794	1134	1759	2220	2676	3935	6811	9866	
500	69.3	123.0	193.0	316.0	494.0	810	1157	1795	2266	2731	4016	6952	10069	
520	70.7	126.0	197.0	323.0	504.0	826	1180	1831	2311	2785	4096	7089	10269	
540	72.1	128.0	201.0	329.0	514.0	842	1203	1866	2355	2838	4174	7224	10464	
560	73.4	131.0	205.0	335.0	523.0	857	1225	1900	2398	2890	4250	7357	10656	
580	74.7	133.0	208.0	341.0	532.0	872	1246	1934	2440	2942	4325	7487	10845	
600	76.0	135.0	212.0	346.0	542.0	887	1268	1967	2482	2992	4399	7615	11030	
620	77.2	137.0	215.0	352.0	551.0	902	1289	1999	2523	3041	4472	7741	11213	
640	78.4	140.0	219.0	358.0	559.0	916	1309	2031	2563	3090	4544	7865	11392	
660	79.7	142.0	222.0	363.0	568.0	930	1329	2063	2603	3138	4614	7987	11569	
680	80.9	144.0	226.0	369.0	577.0	944	1349	2094	2642	3185	4683	8107	11743	

#### NOTES

1. USCS units for water and liquids are U.S. gallons per minute (1 U.S. gallon equals 0.8327 Imperial gallon).
2. Differential pressure ( $\Delta P$ ) equals inlet pressure (set pressure plus overpressure) at flowing conditions minus back pressure.
3. See pages 22 to 55 for minimum and maximum set pressure limits.

\* Capacity in U.S. gallons per minute of water at 70°F and 10% overpressure.

Capacities at 15 psig and above are certified by the National Board of Boiler and Pressure Vessel Inspectors and in accordance with the ASME Boiler and Pressure Vessel Code, Section VIII.

# CROSBY J-SERIES

## DIRECT SPRING PRESSURE RELIEF VALVES

### WATER CAPACITIES - Series JLTJOS-E and JLTJBS-E, USCS Units<sup>[1]</sup> (United States Customary System) (Continued)

Differential pressures  $\Delta P$ <sup>[2]</sup>, 5 - 1040 psi<sup>[3]</sup>

Differential pressure $\Delta P$ - psi	Orifice letter designation and effective area, sq.in.													
	D	E	F	G	H	J	K	L	M	N	P	Q	R	T
700	82.0	146	229	374	585	958	1369	2124	2681	3232	4752	8225	11914	
720	83.2	148	232	380	593	972	1389	2154	2719	3277	4819	8342	12083	
740	84.4	150	235	385	601	985	1408	2184	2756	3323	4886	8457	12250	
760	85.5	152	238	390	610	998	1427	2213	2793	3367	4951	8571	12414	
780	86.6	154	242	395	618	1012	1445	2242	2830	3411	5016	8683	12576	
800	87.7	156	245	400	625	1024	1464	2271	2866	3455	5080	8793	12737	
820	88.8	158	248	405	633	1037	1482	2299	2902	3498	5143	8903	12895	
840	89.9	160	251	410	641	1050	1500	2327	2937	3540	5205	9011	13051	
860	90.9	162	254	415	648	1062	1518	2355	2972	3582	5267	9117		
880	92.0	164	257	420	656	1074	1535	2382	3006	3623	5328	9223		
900	93.0	166	259	424	663	1087	1552	2409	3040	3664	5388	9327		
920	94.1	167	262	429	671	1099	1570	2435	3073	3705	5448	9430		
940	95.1	169	265	434	678	1110	1587	2462	3107	3745	5506	9532		
960	96.1	171	268	438	685	1122	1603	2488	3140	3784	5565	9633		
980	97.1	173	271	443	692	1134	1620	2513	3172	3824	5622	9732		
1000	98.1	175	274	447	699	1145	1636	2539	3204	3863	5679	9831		
1020	99.0	176	276	452	706	1157	1653	2564	3236	3901	5736			
1040	100.0	178	279	456	713	1168	1669	2589	3268	3939	5792			

#### NOTES

1. USCS units for water and liquids are U.S. gallons per minute (1 U.S. gallon equals 0.8327 Imperial gallon).
2. Differential pressure ( $\Delta P$ ) equals inlet pressure (set pressure plus overpressure) at flowing conditions minus back pressure.
3. See pages 22 to 55 for minimum and maximum set pressure limits.

\* Capacity in U.S. gallons per minute of water at 70°F and 10% overpressure.

Capacities at 15 psig and above are certified by the National Board of Boiler and Pressure Vessel Inspectors and in accordance with the ASME Boiler and Pressure Vessel Code, Section VIII.

# CROSBY J-SERIES

## DIRECT SPRING PRESSURE RELIEF VALVES

### WATER CAPACITIES - Series JLTJOS-E and JLTJBS-E, USCS Units<sup>[1]</sup> (United States Customary System) Differential pressures $\Delta P$ <sup>[2]</sup>, 1060 - 6600 psi<sup>[3]</sup>

Differential pressure $\Delta P$ - psi	Orifice letter designation and effective area, sq.in.													
	D	E	F	G	H	J	K	L	M	N	P	Q	R	T
1060	101	180	282	460	720	1179	1685	2614	3299	3977	5847			
1080	102	181	284	465	727	1190	1701	2639	3330	4014	5902			
1100	103	183	287	469	733	1201	1716	2663	3361	4051	5957			
1120	104	185	289	473	740	1212	1732	2687	3391					
1140	105	186	292	478	747	1223	1747	2711	3421					
1160	106	188	295	482	753	1234	1763	2735	3451					
1180	107	190	297	486	760	1244	1778	2758	3481					
1200	107	191	300	490	766	1255	1793	2781	3510					
1220	108	193	302	494	772	1265	1808	2804						
1240	109	194	305	498	779	1275	1822	2827						
1260	110	196	307	502	785	1286	1837	2850						
1280	111	197	309	506	791	1296	1851	2873						
1300	112	199	312	510	797	1306	1866	2895						
1320	113	201	314	514	803	1316	1880	2917						
1340	114	202	317	518	809	1326	1894	2939						
1360	114	204	319	522	815	1336	1908	2961						
1380	115	205	321	525	821	1345	1922	2983						
1400	116	206	324	529	827	1355	1936	3004						
1420	117	208	326	533	833	1365	1950	3026						
1440	118	209	328	537	839	1374	1964	3047						
1460	118	211	331	540	845	1384	1977	3068						
1480	119	212	333	544	851	1393	1991	3089						
1500	120	214	335	548	856	1403	2004	3110						
1600	124	221	346	566	884	1449	2070	3212						
1700	128	228	357	583	912	1493	2134							
1800	132	234	367	600	938	1537	2196							
1900	135	241	377	617	964	1579	2256							
2000	139	247	387	633	989	1620	2314							
2100	142	253	396	648	1013	1660	2371							
2200	145	259	406	663	1037	1699	2427							
2300	149	265	415	678	1060	1737	2482							
2400	152	270	424	693	1083	1774	2535							
2500	155	276	432	707	1106	1811								
2600	158	281	441	721	1127	1847								
2700	161	287	449	735	1149	1882								
2800	164	292	458	748	1170	1917								
2900	167	297	466	762	1191	1950								

#### NOTES

- USCS units for water and liquids are U.S. gallons per minute (1 U.S. gallon equals 0.8327 Imperial gallon).
- Differential pressure ( $\Delta P$ ) equals inlet pressure (set pressure plus overpressure) at flowing conditions minus back pressure.
- See pages 22 to 55 for minimum and maximum set pressure limits.

\* Capacity in U.S. gallons per minute of water at 70°F and 10% overpressure.

Capacities certified by the National Board of Boiler and Pressure Vessel Inspectors and in accordance with the ASME Boiler and Pressure Vessel Code, Section VIII.

**CROSBY J-SERIES**  
**DIRECT SPRING PRESSURE RELIEF VALVES**

**WATER CAPACITIES - Series JLTJOS-E and JLTJBS-E, USCS Units<sup>[1]</sup> (United States Customary System) (Continued)**  
**Differential pressures  $\Delta P$ <sup>[2]</sup>, 1060 - 6600 psi<sup>[3]</sup>**

Differential pressure $\Delta P$ - psi	Orifice letter designation and effective area, sq.in.													
	D	E	F	G	H	J	K	L	M	N	P	Q	R	T
3000	170	302	474	775	1211	1984								
3100	173	307	482	787										
3200	175	312	489	800										
3300	178	317	497	812										
3400	181	322	504	825										
3500	183	327	512	837										
3600	186	331	519	849										
3700	189	336	526	860										
3800	191	340	533	872										
3900	194	345	540	883										
4000	196	349	547	895										
4100	199	353	554											
4200	201	358	561											
4300	203	362	567											
4400	206	366	574											
4500	208	370	580											
4600	210	374	587											
4700	213	378	593											
4800	215	382	599											
4900	217	386	605											
5000	219	390	612											
5500	230	409	641											
6000	240	427												
6600	252	448												

**NOTES**

1. USCS units for water and liquids are U.S. gallons per minute (1 U.S. gallon equals 0.8327 Imperial gallon).
2. Differential pressure ( $\Delta P$ ) equals inlet pressure (set pressure plus overpressure) at flowing conditions minus back pressure.
3. See pages 22 to 55 for minimum and maximum set pressure limits.

\* Capacity in U.S. gallons per minute of water at 70°F and 10% overpressure.

Capacities certified by the National Board of Boiler and Pressure Vessel Inspectors and in accordance with the ASME Boiler and Pressure Vessel Code, Section VIII.

# CROSBY J-SERIES

## DIRECT SPRING PRESSURE RELIEF VALVES

### SATURATED STEAM CAPACITIES, UNFIRED PRESSURE VESSEL SERVICE - Series JOS-E and JBS-E, USCS Units<sup>(1)</sup>

Set pressures 5 - 570 psig

Set pressure (psig)	Orifice letter designation and effective area, sq.in.																
	D	E	F	G	H	J	K	L	M	N	P	Q	R	T	T2	V	W
<b>1 psi incr.</b>	<b>6.1</b>	<b>10.8</b>	<b>17.0</b>	<b>27.8</b>	<b>43.5</b>	<b>71.2</b>	<b>102</b>	<b>158</b>	<b>199</b>	<b>240</b>	<b>353</b>	<b>611</b>	<b>885</b>	<b>1439</b>	<b>1542</b>	<b>2345</b>	<b>3826</b>
<b>5 psi incr.</b>	<b>30.5</b>	<b>54.2</b>	<b>85.0</b>	<b>139</b>	<b>217</b>	<b>356</b>	<b>509</b>	<b>789</b>	<b>996</b>	<b>1201</b>	<b>1765</b>	<b>3056</b>	<b>4426</b>	<b>7193</b>	<b>7711</b>	<b>11723</b>	<b>19132</b>
5			<b>350</b>	<b>573</b>	<b>896</b>	<b>1469</b>	<b>2099</b>					<b>12612</b>					
6			<b>366</b>	<b>599</b>	<b>936</b>	<b>1534</b>	<b>2191</b>	<b>3400</b>				<b>13167</b>					
7			<b>381</b>	<b>624</b>	<b>975</b>	<b>1598</b>	<b>2284</b>	<b>3544</b>			<b>7927</b>	13723					
8		<b>253</b>	<b>397</b>	<b>649</b>	<b>1015</b>	<b>1663</b>	<b>2376</b>	3687	<b>4653</b>	<b>5609</b>	8248	14278	20682	33612	36029		
9		<b>263</b>	<b>412</b>	<b>674</b>	<b>1055</b>	1728	2469	3831	<b>4834</b>	<b>5828</b>	8569	14834	21486	34920	37430		
10		<b>153</b>	<b>273</b>	<b>428</b>	<b>700</b>	1094	1792	2561	3974	5016	6046	8890	15390	22291	36228	38832	
15	181	322	505	826	1292	2116	3024	4692	5921	7137	10495	18168	26315	42767	45842	69695	113746
20	208	371	582	952	1489	2440	3486	5409	6826	8229	12100	20945	30339	49306	52852	80352	131139
30	264	470	737	1205	1884	3087	4411	6844	8637	10412	15310	26501	38386	62385	66871	101666	165924
40	325	578	907	1483	2319	3799	5428	8422	10629	12813	18840	32613	47238	76771	82292	125111	204187
50	386	687	1077	1761	2754	4511	6445	10001	12621	15214	22371	38725	56091	91158	97713	148556	242450
60	447	795	1247	2039	3188	5223	7463	11579	14613	17615	25901	44836	64943	105545	113134	172001	280714
70	508	904	1417	2317	3623	5935	8480	13157	16605	20016	29432	50948	73795	119931	128555	195447	318977
80	569	1012	1587	2595	4058	6647	9497	14736	18597	22417	32963	57059	82647	134318	143976	218892	357241
90	630	1121	1757	2873	4492	7359	10515	16314	20589	24818	36493	63171	91500	148704	159397	242337	395504
100	691	1229	1927	3151	4927	8071	11532	17892	22581	27219	40024	69282	100352	163091	174818	265782	433767
110	752	1338	2097	3429	5361	8783	12549	19471	24573	29620	43554	75394	109204	177477	190239	289227	472031
120	812	1446	2267	3708	5796	9495	13566	21049	26565	32022	47085	81505	118056	191864	205660	312672	510294
130	873	1555	2437	3986	6231	10207	14584	22627	28557	34423	50616	87617	126909	206251	221081	336117	548558
140	934	1663	2607	4264	6665	10919	15601	24206	30549	36824	54146	93729	135761	220637	236502	359562	586821
150	995	1772	2777	4542	7100	11631	16618	25784	32541	39225	57677	99840	144613	235024	251923	383008	625084
160	1056	1880	2947	4820	7535	12343	17636	27363	34533	41626	61207	105952	153465	249410	267344	406453	663348
170	1117	1989	3117	5098	7969	13055	18653	28941	36524	44027	64738	112063	162318	263797	282765	429898	701611
180	1178	2097	3287	5376	8404	13767	19670	30519	38516	46428	68269	118175	171170	278183	298186	453343	739875
190	1239	2206	3457	5654	8839	14479	20687	32098	40508	48829	71799	124286	180022	292570	313607	476788	778138
200	1300	2314	3627	5932	9273	15191	21705	33676	42500	51230	75330	130398	188874	306957	329028	500233	816401
210	1361	2423	3798	6210	9708	15903	22722	35254	44492	53632	78861	136510	197727	321343	344449	523678	854665
220	1422	2531	3968	6488	10143	16615	23739	36833	46484	56033	82391	142621	206579	335730	359870	547123	892928
230	1483	2640	4138	6766	10577	17327	24757	38411	48476	58434	85922	148733	215431	350116	375291	570569	931192
240	1544	2748	4308	7044	11012	18039	25774	39989	50468	60835	89452	154844	224283	364503	390712	594014	969455
250	1605	2857	4478	7322	11447	18751	26791	41568	52460	63236	92983	160956	233136	378889	406133	617459	1007718
260	1666	2965	4648	7600	11881	19463	27808	43146	54452	65637	96514	167067	241988	393276	421554	640904	1045982
270	1727	3074	4818	7878	12316	20175	28826	44725	56444	68038	100044	173179	250840	407663	436975	664349	1084245
280	1788	3182	4988	8156	12751	20887	29843	46303	58436	70439	103575	179290	259693	422049	452396	687794	1122509
290	1849	3291	5158	8434	13185	21599	30860	47881	60428	72840	107105	185402	268545	436436	467817	711239	1160772

\* Numbers marked bold = JOS-E only.

#### NOTES

1. USCS - United States Customary System.
2. Not valid below 30 psig set pressure.
3. Capacities below 30 psig set pressure are calculated at 3 psig overpressure.

\* Capacity in pounds per hour of steam at 10% overpressure.

<sup>3</sup> Valve discharging to atmospheric pressure.

Capacities at 15 psig and above are certified by the National Board of Boiler and Pressure Vessel Inspectors and in accordance with the ASME Boiler and Pressure Vessel Code, Section VIII.

**CROSBY J-SERIES**  
 DIRECT SPRING PRESSURE RELIEF VALVES

**SATURATED STEAM CAPACITIES, UNFIRED PRESSURE VESSEL SERVICE - Series JOS-E and JBS-E, USCS Units<sup>(1)</sup> (CONTINUED)**

Set pressures 5 - 570 psig

Set pressure (psig)	Orifice letter designation and effective area, sq.in.																
	D	E	F	G	H	J	K	L	M	N	P	Q	R	T	T2	V	W
<b>1 psi incr.</b>	<b>6.1</b>	<b>10.8</b>	<b>17.0</b>	<b>27.8</b>	<b>43.5</b>	<b>71.2</b>	<b>102</b>	<b>158</b>	<b>199</b>	<b>240</b>	<b>353</b>	<b>611</b>	<b>885</b>	<b>1439</b>	<b>1542</b>	<b>2345</b>	<b>3826</b>
<b>5 psi incr.</b>	<b>30.5</b>	<b>54.2</b>	<b>85.0</b>	<b>139</b>	<b>217</b>	<b>356</b>	<b>509</b>	<b>789</b>	<b>996</b>	<b>1201</b>	<b>1765</b>	<b>3056</b>	<b>4426</b>	<b>7193</b>	<b>7711</b>	<b>11723</b>	<b>19132</b>
300	1910	3399	5328	8712	13620	22311	31878	49460	62420	75242	110636	191514	277397	450822	483238	734685	1199036
310	1971	3508	5498	8990	14054	23023	32895	51038	64412	77643	114167	197625	286249				
320	2032	3616	5668	9268	14489	23735	33912	52616	66404	80044	117697	203737	295102				
330	2093	3725	5838	9546	14924	24447	34929	54195	68396	82445	121228	209848	303954				
340	2154	3833	6008	9824	15358	25159	35947	55773	70387	84846	124758	215960	312806				
350	2215	3942	6178	10102	15793	25871	36964	57351	72379	87247	128289	222071	321658				
360	2275	4050	6348	10380	16228	26583	37981	58930	74371	89648	131820	228183	330511				
370	2336	4159	6518	10658	16662	27295	38999	60508	76363	92049	135350	234295	339363				
380	2397	4267	6688	10937	17097	28007	40016	62087	78355	94450	138881	240406	348215				
390	2458	4376	6858	11215	17532	28719	41033	63665	80347	96852	142412	246518	357067				
400	2519	4484	7028	11493	17966	29431	42050	65243	82339	99253	145942	252629	365920				
410	2580	4593	7198	11771	18401	30143	43068	66822	84331	101654	149473	258741	374772				
420	2641	4701	7368	12049	18836	30855	44085	68400	86323	104055	153003	264852	383624				
430	2702	4810	7538	12327	19270	31567	45102	69978	88315	106456	156534	270964	392476				
440	2763	4918	7708	12605	19705	32279	46120	71557	90307	108857	160065	277075	401329				
450	2824	5027	7878	12883	20140	32991	47137	73135	92299	111258	163595	283187	410181				
460	2885	5135	8048	13161	20574	33703	48154	74713	94291	113659	167126	289299	419033				
470	2946	5244	8219	13439	21009	34415	49171	76292	96283	116060	170656	295410	427885				
480	3007	5352	8389	13717	21444	35127	50189	77870	98275	118462	174187	301522	436738				
490	3068	5461	8559	13995	21878	35839	51206	79449	100267	120863	177718	307633	445590				
500	3129	5569	8729	14273	22313	36551	52223	81027	102259	123264	181248	313745	454442				
510	3190	5678	8899	14551	22747	37263	53241	82605	104250	125665	184779	319856	463294				
520	3251	5786	9069	14829	23182	37975	54258	84184	106242	128066	188310	325968	472147				
530	3312	5895	9239	15107	23617	38687	55275	85762	108234	130467	191840	332079	480999				
540	3373	6003	9409	15385	24051	39399	56292	87340	110226	132868	195371	338191	489851				
560	3495	6220	9749	15941	24921	40823	58327	90497	114210	137670	202432	350414	507556				
570	3556	6328	9919	16219	25355	41535	59344	92075	116202	140072	205963	356526	516408				

**NOTES**

1. USCS - United States Customary System.
2. Not valid below 30 psig set pressure.
3. Capacities below 30 psig set pressure are calculated at 3 psig overpressure.

\* Capacity in pounds per hour of steam at 10% overpressure.

<sup>3</sup> Valve discharging to atmospheric pressure.

Capacities at 15 psig and above are certified by the National Board of Boiler and Pressure Vessel Inspectors and in accordance with the ASME Boiler and Pressure Vessel Code, Section VIII.



**CROSBY J-SERIES**  
DIRECT SPRING PRESSURE RELIEF VALVES

**SATURATED STEAM CAPACITIES, UNFIRED PRESSURE VESSEL SERVICE - Series JOS-E and JBS-E, USCS Units<sup>(1)</sup>**

Set pressures 580 - 1780 psig

Set pressure (psig)	Orifice letter designation and effective area, sq.in.														
	D	E	F	G	H	J	K	L	M	N	P	Q	R	T	T2
<b>1 psi incr.</b>	<b>6.1</b>	<b>10.8</b>	<b>17.0</b>	<b>27.8</b>	<b>43.5</b>	<b>71.2</b>	<b>102</b>	<b>158</b>	<b>199</b>	<b>240</b>	<b>353</b>	<b>611</b>	<b>885</b>	<b>1439</b>	<b>1542</b>
<b>5 psi incr.</b>	<b>30.5</b>	<b>54.2</b>	<b>85.0</b>	<b>139</b>	<b>217</b>	<b>356</b>	<b>509</b>	<b>789</b>	<b>996</b>	<b>1201</b>	<b>1765</b>	<b>3056</b>	<b>4426</b>	<b>7193</b>	<b>7711</b>
580	3617	6437	10089	16497	25790	42247	60362	93654	118194	142473	209493	362637	525260		
590	3678	6545	10259	16775	26225	42959	61379	95232	120186	144874	213024	368749	534112		
600	3738	6654	10429	17053	26659	43671	62396	96811	122178	147275	216554	374860	542965		
620	3860	6871	10769	17609	27529	45095	64431	99967	126162	152077	223616	387084	560669		
640	3982	7088	11109	18166	28398	46519	66465	103124	130146	156879	230677	399307	578374		
660	4104	7305	11449	18722	29267	47943	68500	106281	134130	161682	237738	411530	596078		
680	4226	7522	11789	19278	30137	49367	70534	109437	138113	166484	244799	423753	613783		
700	4348	7739	12129	19834	31006	50791	72569	112594	142097	171286	251861	435976	631487		
720	4470	7956	12469	20390	31875	52215	74604	115751	146081	176088	258922	448199	649192		
740	4592	8173	12810	20946	32744	53639	76638	118908	150065	180890	265983	460422	666896		
760	4714	8390	13150	21502	33614	55063	78673	122064	154049	185693	273044	472645	684601		
780	4836	8607	13490	22058	34483	56487	80707	125221	158033	190495	280105	484868	702305		
800	4958	8824	13830	22614	35352	57911	82742	128378	162017	195297	287167	497092	720010		
820	5080	9041	14170	23170	36222	59335	84776	131534	166001	200099	294228	509315	737714		
840	5202	9258	14510	23726	37091	60759	86811	134691	169985	204902	301289	521538	755419		
860	5323	9475	14850	24282	37960	62183	88846	137848	173968	209704	308350	533761			
880	5445	9692	15190	24838	38830	63607	90880	141005	177952	214506	315412	545984			
900	5567	9909	15530	25395	39699	65031	92915	144161	181936	219308	322473	558207			
920	5689	10126	15870	25951	40568	66455	94949	147318	185920	224110	329534	570430			
940	5811	10343	16210	26507	41437	67879	96984	150475	189904	228913	336595	582653			
960	5933	10560	16550	27063	42307	69303	99018	153632	193888	233715	343656	594877			
980	6055	10777	16890	27619	43176	70727	101053	156788	197872	238517	350718	607100			
1000	6177	10994	17231	28175	44045	72151	103088	159945	201856	243319	357779	619323			
1020	6299	11211	17571	28731	44915	73575	105122	163102	205839						
1040	6421	11428	17911	29287	45784	74999	107157	166258	209823						
1060	6543	11645	18251	29843	46653	76423	109191	169415	213807						
1080	6665	11862	18591	30399	47523	77847	111226	172572	217791						
1100	6786	12078	18931	30955	48392	79271	113261	175729	221775						
1120	6908	12295	19271	31511	49261	80695	115295	178885							
1140	7030	12512	19611	32067	50130	82119	117330	182042							
1160	7152	12729	19951	32624	51000	83543	119364	185199							
1180	7274	12946	20291	33180	51869	84967	121399	188356							
1200	7396	13163	20631	33736	52738	86391	123433	191512							
1220	7518	13380	20971	34292	53608	87815	125468	194669							
1240	7640	13597	21311	34848	54477	89239	127503	197826							
1260	7762	13814	21651	35404	55346	90663	129537	200982							
1280	7884	14031	21992	35960	56216	92087	131572	204139							

**NOTE**

1. USCS - United States Customary System.

\* Capacity in pounds per hour of steam at 10% overpressure. Valve discharging to atmospheric pressure.

Capacities certified by the National Board of Boiler and Pressure Vessel Inspectors and in accordance with the ASME Boiler and Pressure Vessel Code, Section VIII.

**CROSBY J-SERIES**  
DIRECT SPRING PRESSURE RELIEF VALVES

**SATURATED STEAM CAPACITIES, UNFIRED PRESSURE VESSEL SERVICE - Series JOS-E and JBS-E, USCS Units<sup>(1)</sup> (CONTINUED)**

Set pressures 580 - 1780 psig

Set pressure (psig)	Orifice letter designation and effective area, sq.in.														
	D	E	F	G	H	J	K	L	M	N	P	Q	R	T	T2
<b>1 psi incr.</b>	<b>6.1</b>	<b>10.8</b>	<b>17.0</b>	<b>27.8</b>	<b>43.5</b>	<b>71.2</b>	<b>102</b>	<b>158</b>	<b>199</b>	<b>240</b>	<b>353</b>	<b>611</b>	<b>885</b>	<b>1439</b>	<b>1542</b>
<b>5 psi incr.</b>	<b>30.5</b>	<b>54.2</b>	<b>85.0</b>	<b>139</b>	<b>217</b>	<b>356</b>	<b>509</b>	<b>789</b>	<b>996</b>	<b>1201</b>	<b>1765</b>	<b>3056</b>	<b>4426</b>	<b>7193</b>	<b>7711</b>
1300	8006	14248	22332	36516	57085	93511	133606	207296							
1320	8128	14465	22672	37072	57954	94935	135641	210453							
1340	8249	14682	23012	37628	58823	96359	137675	213609							
1360	8371	14899	23352	38184	59693	97783	139710	216766							
1380	8493	15116	23692	38740	60562	99207	141745	219923							
1400	8615	15333	24032	39296	61431	100631	143779	223080							
1420	8737	15550	24372	39853	62301	102055	145814	226236							
1440	8868	15783	24737	40449	63233	103583	147996	229622							
1460	8999	16016	25102	41047	64167	105113	150183	233015							
1480	9139	16266	25494	41687	65168	106753	152525	236649							
1500	9271	16500	25861	42287	66107	108290	154722	240057							
1520	9403	16735	26229	42889	67047	109830	156922								
1540	9535	16970	26597	43491	67989	111374	159127								
1560	9677	17223	26993	44139	69001	113032	161496								
1580	9810	17459	27364	44744	69948	114582	163711								
1600	9943	17696	27735	45351	70896	116135	165930								
1620	10086	17950	28134	46004	71917	117807	168319								
1640	10219	18188	28507	46613	72869	119368	170549								
1660	10363	18444	28908	47270	73896	121050	172952								
1680	10498	18683	29283	47882	74853	122617	175192								
1700	10642	18941	29687	48543	75886	124309	177609								
1720	10777	19181	30063	49158	76847	125884	179859								
1740	10923	19440	30469	49822	77886	127586	182291								
1760	11058	19681	30847	50440	78852	129168	184551								
1780	11205	19942	31256	51109	79897	130880	186997								

**NOTE**

1. USCS - United States Customary System.

\* Capacity in pounds per hour of steam at 10% overpressure. Valve discharging to atmospheric pressure.

Capacities certified by the National Board of Boiler and Pressure Vessel Inspectors and in accordance with the ASME Boiler and Pressure Vessel Code, Section VIII.

# CROSBY J-SERIES

## DIRECT SPRING PRESSURE RELIEF VALVES

### SATURATED STEAM CAPACITIES, UNFIRED PRESSURE VESSEL SERVICE - Series JOS-E and JBS-E, USCS Units<sup>(1)</sup>

Set pressures 1800 - 2900 psig

Set pressure (psig)	Orifice letter designation and effective area, sq.in.														
	D	E	F	G	H	J	K	L	M	N	P	Q	R	T	T2
<b>1 psi incr.</b>	<b>6.1</b>	<b>10.8</b>	<b>17.0</b>	<b>27.8</b>	<b>43.5</b>	<b>71.2</b>	<b>102</b>	<b>158</b>	<b>199</b>	<b>240</b>	<b>353</b>	<b>611</b>	<b>885</b>	<b>1439</b>	<b>1542</b>
<b>5 psi incr.</b>	<b>30.5</b>	<b>54.2</b>	<b>85.0</b>	<b>139</b>	<b>217</b>	<b>356</b>	<b>509</b>	<b>789</b>	<b>996</b>	<b>1201</b>	<b>1765</b>	<b>3056</b>	<b>4426</b>	<b>7193</b>	<b>7711</b>
1800	11341	20184	31635	51729	80867	132468									
1820	11488	20447	32046	52401	81918	134190									
1840	11636	20710	32459	53076	82973	135918									
1860	11773	20954	32841	53701	83949	137518									
1880	11922	21219	33256	54380	85010	139256									
1900	12071	21484	33673	55060	86075	141000									
1920	12221	21751	34090	55743	87142	142749									
1940	12371	22018	34509	56429	88214	144504									
1960	12510	22265	34896	57061	89203	146124									
1980	12661	22534	35318	57751	90280	147889									
2000	12813	22804	35741	58442	91361	149659									
2020	12965	23074	36165	59136	92445	151435									
2040	13117	23346	36590	59831	93533	153217									
2060	13270	23618	37017	60529	94624	155005									
2080	13424	23892	37446	61230	95719	156798									
2100	13578	24166	37875	61932	96817	158597									
2120	13745	24464	38342	62696	98012	160554									
2140	13901	24740	38775	63404	99118	162365									
2160	14056	25017	39209	64114	100227	164183									
2180	14212	25295	39645	64826	101340	166006									
2200	14382	25597	40119	65601	102553	167993									
2220	14540	25877	40557	66318	103674	169829									
2240	14697	26158	40997	67037	104798	171670									
2260	14869	26464	41477	67822	106024	173680									
2280	15028	26746	41920	68546	107157	175534									
2300	15201	27055	42404	69337	108393	177559									
2320	15376	27365	42889	70131	109634	179593									
2340	15536	27651	43337	70863	110778	181467									
2360	15711	27963	43826	71663	112029	183516									
2380	15888	28276	44318	72467	113285	185574									
2400	16065	28591	44811	73274	114547	187640									
2420	16242	28907	45307	74084	115813	189715									
2440	16421	29225	45804	74897	117085	191798									
2460	16600	29543	46304	75714	118362										
2480	16779	29864	46805	76534	119644										

**NOTE**

1. USCS - United States Customary System.

\* Capacity in pounds per hour of steam at 10% overpressure. Valve discharging to atmospheric pressure.

Capacities certified by the National Board of Boiler and Pressure Vessel Inspectors and in accordance with the ASME Boiler and Pressure Vessel Code, Section VIII.

# CROSBY J-SERIES

## DIRECT SPRING PRESSURE RELIEF VALVES

### SATURATED STEAM CAPACITIES, UNFIRED PRESSURE VESSEL SERVICE - Series JOS-E and JBS-E, USCS Units<sup>[1]</sup> (CONTINUED)

Set pressures 1800 - 2900 psig

Set pressure (psig)	Orifice letter designation and effective area, sq.in.														
	D	E	F	G	H	J	K	L	M	N	P	Q	R	T	T2
<b>1 psi incr.</b>	<b>6.1</b>	<b>10.8</b>	<b>17.0</b>	<b>27.8</b>	<b>43.5</b>	<b>71.2</b>	<b>102</b>	<b>158</b>	<b>199</b>	<b>240</b>	<b>353</b>	<b>611</b>	<b>885</b>	<b>1439</b>	<b>1542</b>
<b>5 psi incr.</b>	<b>30.5</b>	<b>54.2</b>	<b>85.0</b>	<b>139</b>	<b>217</b>	<b>356</b>	<b>509</b>	<b>789</b>	<b>996</b>	<b>1201</b>	<b>1765</b>	<b>3056</b>	<b>4426</b>	<b>7193</b>	<b>7711</b>
2500	16960	30185	47309	77358											
2520	17141	30508	47815	78185											
2540	17339	30859	48366	79086											
2560	17522	31185	48876	79920											
2580	17721	31540	49432	80830											
2600	17906	31868	49947	81671											
2620	18107	32226	50508	82589											
2640	18309	32586	51072	83511											
2660	18512	32948	51639	84438											
2680	18717	33311	52208	85369											
2700	18922	33676	52781	86305											
2720	19128	34043	53356	87245											
2740	19335	34411	53933	88190											
2760	19560	34812	54561	89216											
2780	19769	35184	55144	90170											
2800	19996	35589	55778	91207											
2820	20225	35995	56416	92249											
2840	20455	36404	57057	93297											
2860	20686	36815	57701	94350											
2880	20935	37260	58398	95490											
2900	21169	37675	59049	96555											

#### NOTE

1. USCS - United States Customary System.

\* Capacity in pounds per hour of steam at 10% overpressure. Valve discharging to atmospheric pressure.

Capacities certified by the National Board of Boiler and Pressure Vessel Inspectors and in accordance with the ASME Boiler and Pressure Vessel Code, Section VIII.

# CROSBY J-SERIES

## DIRECT SPRING PRESSURE RELIEF VALVES

Equivalents and conversion factors					
Atmospheres	14.70	Pounds per square inch	Kilograms	2.205	Pounds
Atmospheres	1.033	Kilograms per sq. cm	Kilograms	0.001102	Short tons (2000 lbs.)
Atmospheres	29.92	Inches of mercury	Kilograms	35.27	Ounces
Atmospheres	760.0	Millimeters of mercury	Kilograms per minute	132.3	Pounds per hour
Atmospheres	407.2	Inches of water	Kilograms per sq. cm	14.22	Pounds per sq. in.
Atmospheres	33.93	Feet of water	Kilograms per sq. cm	0.9678	Atmospheres
Atmospheres	1.013	Bars	Kilograms per sq. cm	28.96	Inches of mercury
Atmospheres	101.3	KiloPascals	Kilograms per cubic meter	16.018	Pounds per cubic foot
Barrels	42.00	Gallons (U.S.)	KiloPascals	0.1450	Pounds per sq. in.
Bars	14.50	Pounds per square inch	KiloPascals	0.0100	Bars
Bars	1.020	Kilograms per sq. cm	KiloPascals	0.01020	Kilograms per sq. cm
Bars	100.0	KiloPascals	Liters	0.03532	Cubic feet
Centimeters	0.3937	Inches	Liters	1000	Cubic centimeters
Centimeters	0.03281	Feet	Liters	0.2642	Gallons
Centimeters	0.010	Meters	Liters per hour	0.004403	Gallons per minute
Centimeters	0.01094	Yards	Meters	3.281	Feet
Cubic centimeters	0.06102	Cubic inches	Meters	1.094	Yards
Cubic feet	7.481	Gallons	Meters	100.0	Centimeters
Cubic feet	0.1781	Barrels	Meters	39.37	Inches
Cubic feet per minute	0.02832	Cubic meters per minute	Pounds	0.1199	Gallons H <sub>2</sub> O at 60°F (U.S.)
Cubic feet per second	448.8	Gallons per minute	Pounds	453.6	Grams
Cubic inches	16.39	Cubic centimeters	Pounds	0.0005	Short tons (2000 lbs.)
Cubic inches	0.004329	Gallons	Pounds	0.4536	Kilograms
Cubic meters	264.2	Gallons	Pounds	0.0004536	Metric tons
Cubic meters per hour	4.403	Gallons per minute	Pounds	16.00	Ounces
Cubic meters per minute	35.31	Cubic feet per minute	Pounds per hour	6.323/M.W.	Cubic feet per minute
Standard cubic feet per min.	60.00	Standard cubic ft. per hr	Pounds per hour	0.4536	Kilograms per hour
Standard cubic feet per min.	1440	Standard cubic ft. per day	Pounds per hour liquid	0.002/Sp.Gr.	Gallons per minute liquid (at 60°F)
Standard cubic feet per min.	0.02716	Nm <sup>3</sup> /min.	Pounds per sq. inch	27.68	Inches of water
Standard cubic feet per min.	1.630	Nm <sup>3</sup> /hr.	Pounds per sq. inch	2.307	Feet of water
Standard cubic feet per min.	39.11	Nm <sup>3</sup> /day	Pounds per sq. inch	2.036	Inches of mercury
Standard cubic feet per min.	0.02832	Sm <sup>3</sup> /min.	Pounds per sq. inch	0.07031	Kilograms per sq. cm
Standard cubic feet per min.	1.699	Sm <sup>3</sup> /hr.	Pounds per sq. inch	0.0680	Atmospheres
Standard cubic feet per min.	40.78	Sm <sup>3</sup> /day	Pounds per sq. inch	51.71	Millimeters of mercury
Feet	0.3048	Meters	Pounds per sq. inch	0.7032	Meters of water
Feet	0.3333	Yards	Pounds per sq. inch	0.06895	Bar
Feet	30.48	Centimeters	Pounds per sq. inch	6.895	KiloPascals
Feet of water	0.8818	Inches of mercury	Specific gravity	28.97	Molecular weight (of gas or vapors)
Feet of water	0.4335	Pounds per square inch	(of gas or vapors)		
Gallons (U.S.)	3785	Cubic centimeters	Square centimeter	0.1550	Square inch
Gallons (U.S.)	0.1337	Cubic feet	Square inch	6.4516	Square centimeter
Gallons (U.S.)	231.0	Cubic inches	Square inch	645.16	Square millimeter
Gallons (Imperial)	277.4	Cubic inches	SSU	0.2205 x SG	Centipoise
Gallons (U.S.)	0.8327	Gallons (Imperial)	SSU	0.2162	Centistoke
Gallons (U.S.)	3.785	Liters	Water (cubic feet)	62.4	Pounds (at 60°F)
Gallons of water	8.337	Pounds (at 60°F)	Temperature:		
Gallons of liquid per minute per minute	500 x Sp. Gr.	Pounds per hour liquid (at 60°F)	Centigrade	=	5/9 (Fahrenheit - 32)
Gallons per minute	0.002228	Cubic feet per second	Kelvin	=	Centigrade + 273
Gallons per minute	227.0 x SG	Kilograms per hour	Fahrenheit	=	9/5 (Centigrade) + 32
Gallons per minute	0.06309	Liters per second	Fahrenheit +460°	=	Rankine
Gallons per minute	3.785	Liters per minute	Fahrenheit [°F+460] 5/9	=	Kelvin
Gallons per minute	0.2271	M <sup>3</sup> /hr.			
Grams	0.03527	Ounces			
Inches	2.540	Centimeters			
Inches	0.08333	Feet			
Inches	0.0254	Meters			
Inches	0.02778	Yards			
Inches of mercury	1.133	Feet of water			
Inches of mercury	0.4912	Pounds per square inch			
Inches of mercury	0.03342	Atmospheres			
Inches of mercury	0.03453	Kilograms per sq. cm			
Inches of water	0.03613	Pounds per sq. in.			
Inches of water	0.07355	Inches of mercury			

# CROSBY J-SERIES

## DIRECT SPRING PRESSURE RELIEF VALVES

### AIR CAPACITIES - Series JOS-E, JBS-E, JLTJOS-E AND JLTJBS-E, Metric Units

Set pressures 0.35 - 88 barg

Set pressure (barg)	Orifice letter designation and effective area, sq.mm.																Set pressure (kPa)	
	D	E	F	G	H	J	K	L	M	N	P	Q	R	T	T2	V		W
<b>1 bar incr.</b>	<b>0.8</b>	<b>1.5</b>	<b>2.4</b>	<b>3.8</b>	<b>6</b>	<b>9.8</b>	<b>14.1</b>	<b>21.8</b>	<b>27.6</b>	<b>33.2</b>	<b>48.8</b>	<b>84.5</b>	<b>122.4</b>	<b>199</b>	<b>213.3</b>	<b>324.3</b>	<b>529.2</b>	<b>100 kPa incr.</b>
<b>5 bar incr.</b>	<b>4.2</b>	<b>7.5</b>	<b>11.8</b>	<b>19.2</b>	<b>30.1</b>	<b>49.2</b>	<b>70.4</b>	<b>109.2</b>	<b>137.8</b>	<b>166</b>	<b>244.2</b>	<b>422.6</b>	<b>612.2</b>	<b>994.9</b>	<b>1066.4</b>	<b>1621.3</b>	<b>2646.1</b>	<b>500 kPa incr.</b>
0.35			<b>3.3</b>	<b>5.4</b>	<b>8.5</b>	<b>14.0</b>	<b>20.0</b>						120					35
0.4			<b>3.4</b>	<b>5.6</b>	<b>8.8</b>	<b>14.5</b>	<b>20.7</b>						124					40
0.45			<b>3.5</b>	<b>5.8</b>	<b>9.1</b>	<b>14.9</b>	<b>21.3</b>	<b>33.1</b>					128					45
0.5			<b>3.6</b>	<b>6.0</b>	<b>9.4</b>	<b>15.4</b>	<b>22.0</b>	<b>34.1</b>			<b>76.3</b>	132	191					50
0.55		<b>2.4</b>	<b>3.7</b>	<b>6.1</b>	<b>9.6</b>	<b>15.8</b>	<b>22.6</b>	35.1	<b>44.3</b>	<b>53.4</b>	78.5	136	197	320	343			55
0.6		<b>2.4</b>	<b>3.8</b>	<b>6.3</b>	<b>9.9</b>	<b>16.2</b>	<b>23.2</b>	36.1	<b>45.5</b>	<b>54.9</b>	80.8	139	202	329	352			60
0.65		<b>2.5</b>	<b>3.9</b>	<b>6.5</b>	<b>10.2</b>	16.7	23.9	37.1	<b>46.8</b>	<b>56.4</b>	83.0	143	208	338	362			65
0.7	<b>1.4</b>	<b>2.6</b>	4.1	<b>6.7</b>	10.4	17.1	24.5	38.1	48.0	57.9	85.2	147	213	347	372			70
0.75	<b>1.5</b>	<b>2.6</b>	4.2	<b>6.8</b>	10.7	17.6	25.2	39.1	49.3	59.4	87.4	151	219	356	382			75
0.8	<b>1.5</b>	<b>2.7</b>	4.3	<b>7.0</b>	11.0	18.0	25.8	40.0	50.6	60.9	89.6	155	224	365	391			80
0.85	<b>1.5</b>	<b>2.8</b>	4.4	<b>7.2</b>	11.3	18.5	26.4	41.0	51.8	62.5	91.9	159	230	374	401			85
0.9	<b>1.6</b>	<b>2.8</b>	4.5	<b>7.4</b>	11.5	18.9	27.1	42.0	53.1	64.0	94.1	162	236	383	411	625		90
0.95	<b>1.6</b>	<b>2.9</b>	4.6	<b>7.5</b>	11.8	19.4	27.7	43.0	54.3	65.5	96.3	166	241	392	420	639		95
1	<b>1.7</b>	<b>3.0</b>	4.7	<b>7.7</b>	12.1	19.8	28.4	44.0	55.6	67.0	98.5	170	247	401	430	654		100
2	2.4	4.3	6.8	11.2	17.5	28.8	41.1	63.9	80.6	97.2	142.0	247	358	582	624	949	1549	200
4	4.1	7.3	11.5	18.9	29.5	48.4	69.2	107.0	135.0	163.0	240.0	415	602	979	1049	1595	2604	400
6	5.8	10.3	16.2	26.6	41.6	68.1	97.3	151.0	190.0	229.0	337.0	585	847	1377	1476	2244	3662	600
8	7.5	13.3	20.9	34.3	53.6	87.8	125.0	194.0	245.0	296.0	435.0	754	1092	1775	1902	2892	4721	800
10	9.2	16.3	25.6	41.9	65.6	107.0	153.0	238.0	300.0	362.0	533.0	923	1337	2173	2329	3541	5779	1000
12	10.8	19.3	30.3	49.6	77.6	127.0	181.0	282.0	355.0	429.0	630.0	1092	1582	2571	2755	4189	6838	1200
14	12.5	22.3	35.0	57.3	89.7	146.0	209.0	325.0	411.0	495.0	728.0	1261	1826	2969	3182	4838	7896	1400
16	14.2	25.3	39.7	65.0	101.0	166.0	238.0	369.0	466.0	561.0	826.0	1430	2071	3367	3609	5487	8955	1600
18	15.9	28.3	44.4	72.7	113.0	186.0	266.0	413.0	521.0	628.0	923.0	1599	2316	3764	4035	6135	10013	1800
20	17.6	31.3	49.2	80.4	125.0	206.0	294.0	456.0	576.0	694.0	1021.0	1768	2561	4162	4462	6784	11071	2000
22	19.3	34.3	53.9	88.1	137.0	225.0	322.0	500.0	631.0	761.0	1119.0	1937	2806					2200
24	21.0	37.3	58.6	95.8	149.0	245.0	350.0	544.0	686.0	827.0	1216.0	2106	3051					2400
26	22.6	40.3	63.3	103.0	161.0	265.0	378.0	587.0	741.0	894.0	1314.0	2275	3296					2600
28	24.3	43.3	68.0	111.0	173.0	284.0	406.0	631.0	796.0	960.0	1412.0	2444	3540					2800
30	26.0	46.3	72.7	118.0	185.0	304.0	435.0	675.0	851.0	1026.0	1509.0	2613	3785					3000
32	27.7	49.3	77.4	126.0	197.0	324.0	463.0	718.0	906.0	1093.0	1607.0	2782	4030					3200
34	29.4	52.4	82.1	134.0	209.0	343.0	491.0	762.0	962.0	1159.0	1705.0	2951	4275					3400
36	31.1	55.4	86.8	141.0	221.0	363.0	519.0	806.0	1017.0	1226.0	1802.0	3120	4520					3600
38	32.8	58.4	91.5	149.0	233.0	383.0	547.0	849.0	1072.0	1292.0	1900.0	3289	4765					3800
40	34.5	61.4	96.2	157.0	246.0	402.0	575.0	893.0	1127.0	1358.0	1998.0	3459	5010					4000
42	36.1	64.4	100.0	165.0	258.0	422.0	603.0	936.0	1182.0	1425.0	2095.0	3628	5255					4200
44	37.8	67.4	105.0	172.0	270.0	442.0	632.0	980.0	1237.0	1491.0	2193.0	3797	5499					4400
46	39.5	70.4	110.0	180.0	282.0	462.0	660.0	1024.0	1292.0	1558.0	2291.0	3966	5744					4600
48	41.2	73.4	115.0	188.0	294.0	481.0	688.0	1067.0	1347.0	1624.0	2388.0	4135	5989					4800

\* Numbers marked bold = JOS-E only.

#### NOTE

1. Capacities below 2.0 bar set pressure are calculated at 0.2 bar overpressure.

\* Capacity in standard cubic meters per minute of air at 16°C and 10% overpressure.

<sup>1</sup> Valve discharging to atmospheric pressure.

Capacities certified by the National Board of Boiler and Pressure Vessel Inspectors and in accordance with the ASME Boiler and Pressure Vessel Code, Section VIII.

# CROSBY J-SERIES

## DIRECT SPRING PRESSURE RELIEF VALVES

### AIR CAPACITIES - Series JOS-E, JBS-E, JLTJOS-E AND JLTJBS-E, Metric Units (Continued)

Set pressures 0.35 - 88 barg

Set pressure (barg)	Orifice letter designation and effective area, sq.mm.																Set pressure (kPag)		
	D	E	F	G	H	J	K	L	M	N	P	Q	R	T	T2	V		W	
<b>1 bar incr.</b>	<b>0.8</b>	<b>1.5</b>	<b>2.4</b>	<b>3.8</b>	<b>6</b>	<b>9.8</b>	<b>14.1</b>	<b>21.8</b>	<b>27.6</b>	<b>33.2</b>	<b>48.8</b>	<b>84.5</b>	<b>122.4</b>	<b>199</b>	<b>213.3</b>	<b>324.3</b>	<b>529.2</b>	<b>100 kPa incr.</b>	
<b>5 bar incr.</b>	<b>4.2</b>	<b>7.5</b>	<b>11.8</b>	<b>19.2</b>	<b>30.1</b>	<b>49.2</b>	<b>70.4</b>	<b>109.2</b>	<b>137.8</b>	<b>166</b>	<b>244.2</b>	<b>422.6</b>	<b>612.2</b>	<b>994.9</b>	<b>1066.4</b>	<b>1621.3</b>	<b>2646.1</b>	<b>500 kPa incr.</b>	
50	42.9	76.4	119	195	306	501	716	1111	1402	1691	2486	4304	6234						5000
52	44.6	79.4	124	203	318	521	744	1155	1458	1757	2584	4473	6479						5200
54	46.3	82.4	129	211	330	540	772	1198	1513	1823	2681	4642	6724						5400
56	47.9	85.4	133	218	342	560	800	1242	1568	1890	2779	4811	6969						5600
58	49.6	88.4	138	226	354	580	829	1286	1623	1956	2877	4980	7214						5800
60	51.3	91.4	143	234	366	599	857	1329	1678	2023	2974	5149							6000
62	53.0	94.4	147	241	378	619	885	1373	1733	2089	3072	5318							6200
64	54.7	97.4	152	249	390	639	913	1417	1788	2156	3170	5487							6400
66	56.4	100.0	157	257	402	659	941	1460	1843	2222	3267	5656							6600
68	58.1	103.0	162	265	414	678	969	1504	1898	2288	3365	5825							6800
70	59.7	106.0	166	272	426	698	997	1548	1953										7000
72	61.4	109.0	171	280	438	718	1026	1591	2009										7200
74	63.1	112.0	176	288	450	737	1054	1635	2064										7400
76	64.8	115.0	180	295	462	757	1082	1679											7600
78	66.5	118.0	185	303	474	777	1110	1722											7800
80	68.2	121.0	190	311	486	796	1138	1766											8000
82	69.9	124.0	195	318	498	816	1166	1810											8200
84	71.5	127.0	199	326	510	836	1194	1853											8400
86	73.2	130.0	204	334	522	855	1222	1897											8600
88	74.9	133.0	209	341	534	875	1251	1941											8800

#### NOTE

1. Capacities below 2.0 bar set pressure are calculated at 0.2 bar overpressure.

\* Capacity in standard cubic meters per minute of air at 16°C and 10% overpressure.

<sup>1</sup> Valve discharging to atmospheric pressure.

Capacities certified by the National Board of Boiler and Pressure Vessel Inspectors and in accordance with the ASME Boiler and Pressure Vessel Code, Section VIII.

# CROSBY J-SERIES

## DIRECT SPRING PRESSURE RELIEF VALVES

### AIR CAPACITIES - Series JOS-E, JBS-E, JLTJOS-E AND JLTJBS-E, Metric Units

Set pressures 90 - 410 barg

Set pressure (barg)	Orifice letter designation and effective area, sq.mm.															Set pressure (kPag)	
	D	E	F	G	H	J	K	L	M	N	P	Q	R	T	T2		V
<b>1 bar incr.</b>	<b>0.8</b>	<b>1.5</b>	<b>2.4</b>	<b>3.8</b>	<b>6</b>	<b>9.8</b>	<b>14.1</b>	<b>21.8</b>	<b>27.6</b>	<b>33.2</b>	<b>48.8</b>	<b>84.5</b>	<b>122.4</b>	<b>199</b>	<b>213.3</b>	<b>324.3</b>	<b>100 kPa incr.</b>
<b>5 bar incr.</b>	<b>4.2</b>	<b>7.5</b>	<b>11.8</b>	<b>19.2</b>	<b>30.1</b>	<b>49.2</b>	<b>70.4</b>	<b>109.2</b>	<b>137.8</b>	<b>166</b>	<b>244.2</b>	<b>422.6</b>	<b>612.2</b>	<b>994.9</b>	<b>1066.4</b>	<b>1621.3</b>	<b>500 kPa incr.</b>
90	76.6	136	213	349	546	895	1279	1984									9000
92	78.3	139	218	357	558	915	1307	2028									9200
94	80.0	142	223	365	570	934	1335	2072									9400
96	81.7	145	227	372	582	954	1363	2115									9600
98	83.4	148	232	380	594	974	1391	2159									9800
100	85.0	151	237	388	606	993	1419	2203									10000
102	86.7	154	242	395	618	1013	1448	2246									10200
104	88.4	157	246	403	630	1033	1476										10400
106	90.1	160	251	411	642	1052	1504										10600
108	91.8	163	256	418	654	1072	1532										10800
110	93.5	166	260	426	666	1092	1560										11000
112	95.2	169	265	434	678	1112	1588										11200
114	96.8	172	270	441	690	1131	1616										11400
116	98.5	175	274	449	702	1151	1645										11600
118	100.0	178	279	457	714	1171	1673										11800
120	101.0	181	284	465	726	1190	1701										12000
122	103.0	184	289	472	738	1210	1729										12200
124	105.0	187	293	480	750	1230	1757										12400
126	107.0	190	298	488	763	1249	1785										12600
128	108.0	193	303	495	775	1269	1813										12800
130	110.0	196	307	503	787	1289	1842										13000
132	112.0	199	312	511	799	1308	1870										13200
134	113.0	202	317	518	811	1328	1898										13400
136	115.0	205	322	526	823	1348	1926										13600
138	117.0	208	326	534	835	1368	1954										13800
140	118.0	211	331	541	847	1387	1982										14000
142	120.0	214	336	549	859	1407	2010										14200
144	122.0	217	340	557	871	1427	2039										14400
146	123.0	220	345	564	883	1446	2067										14600
148	125.0	223	350	572	895	1466	2095										14800
150	127.0	226	354	580	907	1486	2123										15000
160	135.0	241	378	618	967	1584											16000
170	144.0	256	401	657	1027	1683											17000
180	152.0	271	425	695	1087	1781											18000
190	160.0	286	449	734	1147												19000

\* Capacity in standard cubic meters per minute of air at 16°C and 10% overpressure.

<sup>1</sup> Valve discharging to atmospheric pressure.

Capacities certified by the National Board of Boiler and Pressure Vessel Inspectors and in accordance with the ASME Boiler and Pressure Vessel Code, Section VIII.



# CROSBY J-SERIES

## DIRECT SPRING PRESSURE RELIEF VALVES

### AIR CAPACITIES - Series JOS-E, JBS-E, JLTJOS-E AND JLTJBS-E, Metric Units (Continued)

#### Set pressures 90 - 410 barg

Set pressure (barg)	Orifice letter designation and effective area, sq.mm.															Set pressure (kPag)	
	D	E	F	G	H	J	K	L	M	N	P	Q	R	T	T2		V
<b>1 bar incr.</b>	<b>0.8</b>	<b>1.5</b>	<b>2.4</b>	<b>3.8</b>	<b>6</b>	<b>9.8</b>	<b>14.1</b>	<b>21.8</b>	<b>27.6</b>	<b>33.2</b>	<b>48.8</b>	<b>84.5</b>	<b>122.4</b>	<b>199</b>	<b>213.3</b>	<b>324.3</b>	<b>100 kPa incr.</b>
<b>5 bar incr.</b>	<b>4.2</b>	<b>7.5</b>	<b>11.8</b>	<b>19.2</b>	<b>30.1</b>	<b>49.2</b>	<b>70.4</b>	<b>109.2</b>	<b>137.8</b>	<b>166</b>	<b>244.2</b>	<b>422.6</b>	<b>612.2</b>	<b>994.9</b>	<b>1066.4</b>	<b>1621.3</b>	<b>500 kPa incr.</b>
200	169	301	472	772													20000
210	177	316	496	811													21000
220	186	331	519	849													22000
230	194	346	543	888													23000
240	203	361	566	926													24000
250	211	376	590	964													25000
260	219	391	613														26000
270	228	406	637														27000
280	236	421	660														28000
290	245	436	684														29000
300	253	451	707														30000
310	262	466	731														31000
320	270	481	754														32000
330	279	496	778														33000
340	287	511	801														34000
350	295	526															35000
360	304	541															36000
370	312	556															37000
380	321	571															38000
390	329	586															39000
400	338	601															40000
410	346	616															41000

\* Capacity in standard cubic meters per minute of air at 16°C and 10% overpressure.

<sup>1</sup> Valve discharging to atmospheric pressure.

Capacities certified by the National Board of Boiler and Pressure Vessel Inspectors and in accordance with the ASME Boiler and Pressure Vessel Code, Section VIII.

# CROSBY J-SERIES

## DIRECT SPRING PRESSURE RELIEF VALVES

### WATER CAPACITIES - Series JLTJOS-E and JLTJBS-E, Metric Units

Differential pressures  $\Delta P^{(1)}$ , 1 - 80 bar<sup>(2)</sup>

Differential pressure $\Delta P$ - bar	Orifice letter designation and effective area, sq.in.														Differential pressure $\Delta P$ - kPa
	D	E	F	G	H	J	K	L	M	N	P	Q	R	T	
1	45	80	124	203	318	522	746	1157	1460	1760	2589	4481	6491	10550	100
2	63	112	176	288	450	738	1055	1636	2065	2490	3661	6338	9180	14920	200
3	77	137	215	353	552	904	1292	2004	2530	3049	4484	7762	11244	18273	300
4	89	159	249	407	637	1044	1492	2314	2921	3521	5178	8963	12983	21100	400
5	100	177	278	455	712	1167	1668	2588	3266	3937	5789	10021	14516	23591	500
6	109	194	305	499	780	1278	1827	2835	3578	4313	6342	10978	15901	25843	600
7	118	210	329	539	843	1381	1973	3062	3864	4658	6850	11858	17175	27913	700
8	126	225	352	576	901	1476	2110	3273	4131	4980	7323	12676	18361	29841	800
9	134	238	374	611	956	1566	2238	3472	4382	5282	7767	13445	19475	31651	900
10	141	251	394	644	1007	1651	2359	3660	4619	5568	8187	14173	20528	33363	1000
11	148	263	413	676	1057	1731	2474	3838	4844	5840	8587	14864	21530	34991	1100
12	154	275	431	706	1104	1808	2584	4009	5060	6099	8969	15525	22488	36547	1200
13	161	286	449	735	1149	1882	2689	4173	5266	6348	9335	16159	23406	38040	1300
14	167	297	466	762	1192	1953	2791	4330	5465	6588	9687	16769	24290	39475	1400
15	173	308	482	789	1234	2022	2889	4482	5657	6819	10027	17358	25142	40861	1500
16	178	318	498	815	1275	2088	2984	4629	5843	7043	10356	17927	25967	42201	1600
17	184	328	514	840	1314	2152	3075	4772	6022	7260	10675	18479	26766	43500	1700
18	189	337	529	865	1352	2215	3165	4910	6197	7470	10984	19015	27542	44761	1800
19	194	346	543	888	1389	2275	3251	5045	6367	7675	11285	19536	28297	45988	1900
20	199	355	557	911	1425	2335	3336	5176	6532	7874	11579	20043	29032	47182	2000
21	204	364	571	934	1460	2392	3418	5304	6694	8069	11865	20538	29749	48348	2100
22	209	373	584	956	1495	2449	3499	5429	6851	8259	12144	21022	30449	49485	2200
23	214	381	598	977	1528	2504	3577	5551	7005	8444	12417	21494	31133	50597	2300
24	219	389	610	998	1561	2557	3654	5670	7156	8626	12684	21956	31803	51761	2400
25	223	397	623	1019	1593	2610	3730	5787	7303	8804	12945	22409	32459	52925	2500
26	227	405	635	1039	1625	2662	3804	5902	7448	8978	13202	22853	33101	54089	2600
27	232	413	647	1059	1656	2713	3876	6014	7590	9149	13453	23288	33732	55253	2700
28	236	421	659	1078	1686	2762	3947	6124	7729	9317	13700	23716	34351	56417	2800
29	240	428	671	1098	1716	2811	4017	6233	7866	9482	13943	24135	34959	57581	2900
30	244	435	682	1116	1745	2859	4086	6339	8001	9644	14181	24548	35557	58745	3000
31	248	442	694	1135	1774	2907	4153	6444	8133	9804	14415	24954	36144	59909	3100
32	252	450	705	1153	1803	2953	4220	6547	8263	9960	14646	25353	36723	61073	3200
33	256	457	716	1171	1831	2999	4285	6649	8391	10115	14873	25746	37292	62237	3300
34	260	463	727	1188	1858	3044	4350	6749	8517	10267	15097	26133	37853	63401	3400
35	264	470	737	1206	1885	3089	4413	6847	8642	10417	15317	26515	38406	64565	3500
36	268	477	748	1223	1912	3132	4476	6944	8764	10565	15535	26891	38950	65729	3600
37	271	483	758	1240	1938	3176	4537	7040	8885	10710	15749	27262	39488	66893	3700
38	275	490	768	1256	1964	3218	4598	7135	9004	10854	15960	27628	40018	68057	3800
39	279	496	778	1273	1990	3260	4658	7228	9122	10996	16169	27989	40541	69221	3900

#### NOTES

- Differential pressure ( $\Delta P$ ) equals inlet pressure (set pressure plus overpressure) at flowing conditions minus back pressure.
- See pages 22 to 55 for minimum and maximum set pressure limits.

\* Capacity in liters per minute of water at 21°C and 10% overpressure.

Capacities certified by the National Board of Boiler and Pressure Vessel Inspectors and in accordance with the ASME Boiler and Pressure Vessel Code, Section VIII.

# CROSBY J-SERIES

## DIRECT SPRING PRESSURE RELIEF VALVES

### WATER CAPACITIES - Series JLTJOS-E and JLTJBS-E, Metric Units (Continued)

Differential pressures  $\Delta P^{[1]}$ , 1 - 80 bar<sup>[2]</sup>

Differential pressure $\Delta P$ - bar	Orifice letter designation and effective area, sq.in.														Differential pressure $\Delta P$ - kPa
	D	E	F	G	H	J	K	L	M	N	P	Q	R	T	
40	282	503	788	1289	2015	3302	4718	7320	9238	11136	16375	28346	41057	4000	
41	286	509	798	1305	2041	3343	4776	7411	9353	11274	16578	28698	41567	4100	
42	289	515	808	1321	2065	3383	4834	7501	9467	11411	16779	29046	42071	4200	
43	293	521	817	1337	2090	3423	4892	7590	9579	11546	16978	29389	42569	4300	
44	296	527	827	1352	2114	3463	4948	7677	9689	11680	17174	29729	43061	4400	
45	299	533	836	1367	2138	3502	5004	7764	9799	11812	17368	30065	43548	4500	
46	303	539	845	1382	2161	3541	5059	7850	9907	11942	17560	30397	44029	4600	
47	306	545	854	1397	2185	3579	5114	7935	10014	12071	17750	30726	44505	4700	
48	309	551	863	1412	2208	3617	5168	8019	10120	12199	17938	31051	44976	4800	
49	312	556	872	1427	2231	3655	5222	8102	10225	12325	18124	31373	45442	4900	
50	316	562	881	1441	2253	3692	5275	8184	10329	12451	18308	31691	45904	5000	
52	322	573	899	1470	2298	3765	5379	8346	10533	12697	18670	32319	46813	5200	
54	328	584	916	1498	2342	3836	5482	8505	10734	12939	19026	32935	47704	5400	
56	334	595	933	1525	2385	3907	5582	8661	10931	13177	19375	33539	48580	5600	
58	340	605	949	1552	2427	3976	5681	8815	11125	13410	19718	34133	49440	5800	
60	346	616	965	1579	2469	4044	5778	8965	11315	13639	20055	34716	50285	6000	
62	352	626	981	1605	2509	4111	5874	9114	11502	13864	20387	35290	51125	6200	
64	357	636	997	1631	2550	4177	5968	9259	11686	14086	20713	35855	52000	6400	
66	363	646	1013	1656	2589	4241	6060	9403	11867	14305	21034	36411	52900	6600	
68	368	656	1028	1681	2628	4305	6151	9544	12045	14520	21350	36958	53800	6800	
70	374	665	1043	1705	2666	4368	6241	9684	12221	14732	21662	37498	54700	7000	
72	379	675	1058	1730	2704	4430	6330	9821	12395	14941	21969	38030	55600	7200	
74	384	684	1072	1754	2741	4491	6417	9957	12566	15147	22272	38554	56500	7400	
76	389	693	1087	1777	2778	4551	6503	10090	12734					7600	
78	394	702	1101	1800	2815	4611	6588	10222	12901					7800	
80	399	711	1115	1823	2850	4670	6672	10352	13065					8000	

#### NOTES

- Differential pressure ( $\Delta P$ ) equals inlet pressure (set pressure plus overpressure) at flowing conditions minus back pressure.
- See pages 22 to 55 for minimum and maximum set pressure limits.

\* Capacity in liters per minute of water at 21°C and 10% overpressure.

Capacities certified by the National Board of Boiler and Pressure Vessel Inspectors and in accordance with the ASME Boiler and Pressure Vessel Code, Section VIII.

# CROSBY J-SERIES

## DIRECT SPRING PRESSURE RELIEF VALVES

### WATER CAPACITIES - Series JLTJOS-E and JLTJBS-E, Metric Units

Differential pressures  $\Delta P^{[1]}$ , 82 - 455 BAR<sup>[2]</sup>

Differential pressure $\Delta P$ - bar	Orifice letter designation and effective area, sq.in.														Differential pressure $\Delta P$ - kPa
	D	E	F	G	H	J	K	L	M	N	P	Q	R	T	
82	404	720	1129	1846	2886	4728	6755	10481	13228						8200
84	409	729	1142	1868	2921	4785	6837	10608	13388						8400
86	414	737	1156	1890	2955	4842	6918	10734							8600
88	419	746	1169	1912	2990	4898	6998	10858							8800
90	424	754	1182	1934	3023	4953	7077	10980							9000
92	428	763	1196	1955	3057	5008	7155	11102							9200
94	433	771	1208	1976	3090	5062	7233	11222							9400
96	438	779	1221	1997	3123	5115	7309	11341							9600
98	442	787	1234	2018	3155	5168	7385	11458							9800
100	447	795	1246	2038	3187	5221	7460	11574							10000
102	451	803	1259	2059	3219	5273	7534	11690							10200
104	455	811	1271	2079	3250	5324	7608	11804							10400
106	460	819	1283	2099	3281	5375	7680	11917							10600
108	464	826	1295	2118	3312	5426	7752	12029							10800
110	468	834	1307	2138	3343	5476	7824	12139							11000
112	473	842	1319	2157	3373	5525	7895	12249							11200
114	477	849	1331	2177	3403	5575	7965	12358							11400
116	481	856	1343	2196	3433	5623	8034								11600
118	485	864	1354	2214	3462	5671	8103								11800
120	489	871	1365	2233	3491	5719	8172								12000
122	493	878	1377	2252	3520	5767	8240								12200
124	497	885	1388	2270	3549	5814	8307								12400
126	501	893	1399	2288	3577	5861	8374								12600
128	505	900	1410	2306	3606	5907	8440								12800
130	509	907	1421	2324	3634	5953	8506								13000
132	513	914	1432	2342	3662	5999	8571								13200
134	517	920	1443	2360	3689	6044	8635								13400
136	521	927	1454	2377	3717	6089	8700								13600
138	525	934	1464	2395	3744	6133	8763								13800
140	528	941	1475	2412	3771	6178	8827								14000
142	532	948	1485	2429	3798	6222	8889								14200
144	536	954	1496	2446	3825	6265	8952								14400
146	540	961	1506	2463	3851	6309	9014								14600
148	543	967	1517	2480	3877	6352	9075								14800
150	547	974	1527	2497	3903	6394	9136								15000
160	565	1006	1577	2579	4031	6604	9436								16000
170	582	1037	1625	2658	4156	6807									17000
180	599	1067	1672	2735	4276	7005									18000
190	616	1096	1718	2810	4393	7197									19000

#### NOTES

1. Differential pressure ( $\Delta P$ ) equals inlet pressure (set pressure plus overpressure) at flowing conditions minus back pressure.
2. See pages 22 to 55 for minimum and maximum set pressure limits.

\* Capacity in liters per minute of water at 21°C and 10% overpressure.

Capacities certified by the National Board of Boiler and Pressure Vessel Inspectors and in accordance with the ASME Boiler and Pressure Vessel Code, Section VIII.

# CROSBY J-SERIES

## DIRECT SPRING PRESSURE RELIEF VALVES

### WATER CAPACITIES - Series JLTJOS-E and JLTJBS-E, Metric Units (Continued)

Differential pressures  $\Delta P^{[1]}$ , 82 - 455 BAR<sup>[2]</sup>

Differential pressure $\Delta P$ - bar	Orifice letter designation and effective area, sq.in.														Differential pressure $\Delta P$ - kPa
	D	E	F	G	H	J	K	L	M	N	P	Q	R	T	
200	632	1125	1763	2883	4507	7384									20000
210	647	1152	1807	2954											21000
220	663	1180	1849	3024											22000
230	677	1206	1891	3092											23000
240	692	1232	1931	3158											24000
250	706	1257	1971	3223											25000
260	720	1282	2010	3287											26000
270	734	1307	2048	3350											27000
280	748	1331	2086	3411											28000
290	761	1354	2123												29000
300	774	1378	2159												30000
310	787	1400	2195												31000
320	799	1423	2230												32000
330	812	1445	2265												33000
340	824	1467	2299												34000
350	836	1488	2332												35000
360	848	1509	2365												36000
370	859	1530	2398												37000
380	871	1550													38000
390	882	1571													39000
400	894	1591													40000
410	905	1611													41000
420	916	1630													42000
430	927	1649													43000
440	937	1668													44000
450	948	1687													45000
455	953	1697													45500

#### NOTES

1. Differential pressure ( $\Delta P$ ) equals inlet pressure (set pressure plus overpressure) at flowing conditions minus back pressure.
2. See pages 22 to 55 for minimum and maximum set pressure limits.

\* Capacity in liters per minute of water at 21°C and 10% overpressure.

Capacities certified by the National Board of Boiler and Pressure Vessel Inspectors and in accordance with the ASME Boiler and Pressure Vessel Code, Section VIII.

# CROSBY J-SERIES

## DIRECT SPRING PRESSURE RELIEF VALVES

### SATURATED STEAM CAPACITIES, UNFIRED PRESSURE VESSEL SERVICE - Series JOS-E and JBS-E, Metric Units - Set Pressures 0.35 - 76 barg

Set pressure (barg)	Orifice letter designation and effective area, sq.mm.																
	D	E	F	G	H	J	K	L	M	N	P	Q	R	T	T2	V	W
<b>1 bar incr.<sup>2</sup></b>	<b>71</b>	<b>126</b>	<b>198</b>	<b>325</b>	<b>506</b>	<b>830</b>	<b>1186</b>	<b>1841</b>	<b>2323</b>	<b>2800</b>	<b>4116</b>	<b>7129</b>	<b>10323</b>	<b>16774</b>	<b>17981</b>	<b>27218</b>	<b>39193</b>
<b>5 bar incr.<sup>2</sup></b>	<b>201</b>	<b>357</b>	<b>559</b>	<b>915</b>	<b>1430</b>	<b>2342</b>	<b>3346</b>	<b>5192</b>	<b>6552</b>	<b>7898</b>	<b>11614</b>	<b>20103</b>	<b>29119</b>	<b>47323</b>	<b>50726</b>	<b>77120</b>	<b>125864</b>
0.35			<b>159</b>	<b>261</b>	<b>408</b>	<b>668</b>	<b>955</b>						5739				
0.4			<b>164</b>	<b>269</b>	<b>421</b>	<b>690</b>	<b>985</b>						5922				
0.45			<b>169</b>	<b>277</b>	<b>434</b>	<b>711</b>	<b>1016</b>	<b>1576</b>					6105				
0.5			<b>174</b>	<b>286</b>	<b>447</b>	<b>732</b>	<b>1046</b>	<b>1623</b>			<b>3632</b>	6288					
0.55		<b>114</b>	<b>180</b>	<b>294</b>	<b>460</b>	<b>753</b>	<b>1077</b>	1671	<b>2109</b>	<b>2542</b>	3738	6470	9372	15232	16327		
0.6		<b>118</b>	<b>185</b>	<b>302</b>	<b>473</b>	<b>775</b>	<b>1107</b>	1718	<b>2168</b>	<b>2614</b>	3843	6653	9637	15662	16789		
0.65		<b>121</b>	<b>190</b>	<b>311</b>	<b>486</b>	796	1137	1765	<b>2228</b>	<b>2685</b>	3949	6836	9902	16093	17250		
0.7	<b>70.0</b>	<b>124</b>	195	<b>319</b>	499	817	1168	1812	2287	2757	4054	7019	10167	16523	17711		
0.75	<b>71.8</b>	<b>127</b>	200	<b>327</b>	512	839	1198	1859	2347	2829	4160	7202	10431	16953	18172		
0.8	<b>73.6</b>	<b>131</b>	205	<b>335</b>	525	860	1229	1907	2406	2901	4266	7384	10696	17383	18633		
0.85	<b>75.4</b>	<b>134</b>	210	<b>344</b>	538	881	1259	1954	2466	2973	4371	7567	10961	17813	19094		
0.9	<b>77.3</b>	<b>137</b>	215	<b>352</b>	551	902	1290	2001	2526	3044	4477	7750	11225	18244	19555		
0.95	<b>79.1</b>	<b>140</b>	220	<b>360</b>	564	924	1320	2048	2585	3116	4582	7933	11490	18674	20017		
1	<b>80.9</b>	<b>144</b>	225	<b>369</b>	577	945	1350	2095	2645	3188	4688	8115	11755	19104	20478		
2	117.0	208	327	535	837	1371	1959	3039	3836	4624	6800	11770	17049	27708	29701	45155	73695
3	157.0	279	438	717	1121	1836	2624	4071	5138	6194	9108	15766	22837	37114	39783	60483	98712
4	197.0	351	550	900	1407	2305	3293	5110	6449	7774	11431	19787	28660	46579	49928	75907	123884
5	237.0	422	662	1083	1693	2773	3962	6148	7759	9353	13753	23807	34484	56043	60073	91332	149057
6	277.0	494	774	1266	1979	3242	4632	7186	9070	10933	16076	27828	40308	65508	70218	106756	174230
7	317.0	565	886	1448	2265	3710	5301	8225	10380	12512	18399	31849	46131	74973	80363	122180	199403
8	357.0	636	997	1631	2551	4178	5970	9263	11691	14092	20721	35870	51955	84437	90509	137604	224575
9	397.0	708	1109	1814	2836	4647	6639	10302	13001	15672	23044	39890	57779	93902	100654	153028	249748
10	437.0	779	1221	1997	3122	5115	7309	11340	14312	17251	25367	43911	63603	103367	110799	168452	274921
11	478.0	850	1333	2180	3408	5584	7978	12378	15622	18831	27690	47932	69426	112831	120944	183876	300093
12	518.0	922	1445	2363	3694	6052	8647	13417	16932	20411	30012	51952	75250	122296	131089	199300	325266
13	558.0	993	1557	2546	3980	6520	9316	14455	18243	21990	32335	55973	81074	131760	141234	214724	350439
14	598.0	1065	1669	2729	4266	6989	9986	15493	19553	23570	34658	59994	86898	141225	151380	230148	375612
15	638.0	1136	1781	2912	4552	7457	10655	16532	20864	25150	36980	64014	92721	150690	161525	245572	400784
16	678.0	1207	1892	3095	4838	7926	11324	17570	22174	26729	39303	68035	98545	160154	171670	260996	425957
17	718.0	1279	2004	3278	5124	8394	11993	18609	23485	28309	41626	72056	104369	169619	181815	276421	451130
18	758.0	1350	2116	3461	5410	8863	12663	19647	24795	29889	43949	76076	110192	179084	191960	291845	476303
19	798.0	1421	2228	3643	5696	9331	13332	20685	26106	31468	46271	80097	116016	188548	202105	307269	501475
20	839.0	1493	2340	3826	5982	9799	14001	21724	27416	33048	48594	84118	121840	198013	212251	322693	526648
22	919.0	1635	2564	4192	6554	10736	15340	23800	30037	36207	53239	92159	133487				
24	999.0	1778	2787	4558	7126	11673	16678	25877	32658	39366	57885	100200	145135				
26	1079.0	1921	3011	4924	7698	12610	18017	27954	35279	42526	62530	108242	156782				
28	1159.0	2064	3235	5290	8270	13547	19355	30031	37900	45685	67176	116283	168430				
30	1240.0	2206	3459	5656	8841	14483	20694	32107	40521	48844	71821	124324	180077				
32	1320.0	2349	3682	6021	9413	15420	22032	34184	43142	52004	76467	132366	191725				
34	1400.0	2492	3906	6387	9985	16357	23371	36261	45763	55163	81112	140407	203372				
36	1480.0	2635	4130	6753	10557	17294	24709	38338	48383	58322	85758	148448	215019				
38	1560.0	2777	4353	7119	11129	18231	26048	40414	51004	61481	90403	156490	226667				

\* Numbers marked bold = JOS-E only.

#### NOTES

1. Capacities below 2.0 bar set pressure are calculated at 0.2 at bar overpressure.
2. Not valid below 2.0 bar set pressure.

\* Capacity in kilograms per hour of steam at 10% overpressure.

<sup>1</sup> Valve discharging to atmospheric pressure.

Capacities certified by the National Board of Boiler and Pressure Vessel Inspectors and in accordance with the ASME Boiler and Pressure Vessel Code, Section VIII.

# CROSBY J-SERIES

## DIRECT SPRING PRESSURE RELIEF VALVES

### SATURATED STEAM CAPACITIES, UNFIRED PRESSURE VESSEL SERVICE - Series JOS-E and JBS-E, Metric Units - Set Pressures 0.35 - 76 barg (CONTINUED)

Set pressure (barg)	Orifice letter designation and effective area, sq.mm.																
	D	E	F	G	H	J	K	L	M	N	P	Q	R	T	T2	V	W
<b>1 bar incr.<sup>2</sup></b>	<b>40</b>	<b>71</b>	<b>112</b>	<b>183</b>	<b>286</b>	<b>468</b>	<b>669</b>	<b>1038</b>	<b>1310</b>	<b>1580</b>	<b>2323</b>	<b>4021</b>	<b>5824</b>	<b>9465</b>	<b>10145</b>	<b>15424</b>	<b>25173</b>
<b>5 bar incr.<sup>2</sup></b>	<b>201</b>	<b>357</b>	<b>559</b>	<b>915</b>	<b>1430</b>	<b>2342</b>	<b>3346</b>	<b>5192</b>	<b>6552</b>	<b>7898</b>	<b>11614</b>	<b>20103</b>	<b>29119</b>	<b>47323</b>	<b>50726</b>	<b>77120</b>	<b>125864</b>
40	1641	2920	4577	7485	11701	19168	27386	42491	53625	64641	95048	164531	238314				
42	1721	3063	4801	7851	12273	20104	28725	44568	56246	67800	99694	172572	249962				
44	1801	3206	5025	8216	12845	21041	30063	46645	58867	70959	104339	180614	261609				
46	1881	3348	5248	8582	13417	21978	31402	48721	61488	74119	108985	188655	273257				
48	1961	3491	5472	8948	13988	22915	32740	50798	64109	77278	113630	196696	284904				
50	2042	3634	5696	9314	14560	23852	34079	52875	66730	80437	118276	204738	296552				
52	2122	3777	5920	9680	15132	24789	35417	54952	69351	83596	122921	212779	308199				
54	2202	3919	6143	10046	15704	25725	36756	57028	71972	86756	127566	220821	319846				
56	2282	4062	6367	10411	16276	26662	38094	59105	74593	89915	132212	228862	331494				
58	2362	4205	6591	10777	16848	27599	39433	61182	77214	93074	136857	236903	343141				
60	2443	4348	6814	11143	17420	28536	40771	63259	79834	96234	141503	244945					
62	2523	4490	7038	11509	17992	29473	42110	65335	82455	99393	146148	252986					
64	2603	4633	7262	11875	18564	30409	43448	67412	85076	102552	150794	261027					
66	2683	4776	7486	12241	19136	31346	44787	69489	87697	105711	155439	269069					
68	2763	4919	7709	12606	19707	32283	46125	71566	90318	108871	160085	277110					
70	2844	5061	7933	12972	20279	33220	47464	73642	92939								
72	2924	5204	8157	13338	20851	34157	48802	75719	95560								
74	3004	5347	8381	13704	21423	35094	50141	77796	98181								
76	3084	5490	8604	14070	21995	36030	51479	79873									

#### NOTES

1. Capacities below 2.0 bar set pressure are calculated at 0.2 at bar overpressure.
2. Not valid below 2.0 bar set pressure.

\* Capacity in kilograms per hour of steam at 10% overpressure.

<sup>1</sup> Valve discharging to atmospheric pressure.

Capacities certified by the National Board of Boiler and Pressure Vessel Inspectors and in accordance with the ASME Boiler and Pressure Vessel Code, Section VIII.

# CROSBY J-SERIES

## DIRECT SPRING PRESSURE RELIEF VALVES

### SATURATED STEAM CAPACITIES, UNFIRED PRESSURE VESSEL SERVICE - Series JOS-E and JBS-E, Metric Units - Set Pressures 78 - 200 barg

Set pressure (barg)	Orifice letter designation and effective area, sq.mm.														
	D	E	F	G	H	J	K	L	M	N	P	Q	R	T	T2
<b>1 bar incr.<sup>2</sup></b>	<b>40</b>	<b>71</b>	<b>112</b>	<b>183</b>	<b>286</b>	<b>468</b>	<b>669</b>	<b>1038</b>	<b>1310</b>	<b>1580</b>	<b>2323</b>	<b>4021</b>	<b>5824</b>	<b>9465</b>	<b>10145</b>
<b>5 bar incr.<sup>2</sup></b>	<b>201</b>	<b>357</b>	<b>559</b>	<b>915</b>	<b>1430</b>	<b>2342</b>	<b>3346</b>	<b>5192</b>	<b>6552</b>	<b>7898</b>	<b>11641</b>	<b>20103</b>	<b>29119</b>	<b>47323</b>	<b>50726</b>
78	3165	5632	8828	14435	22567	36967	52818	81949							
80	3245	5775	9052	14801	23139	37904	54156	84026							
82	3325	5918	9275	15167	23711	38841	55495	86103							
84	3405	6061	9499	15533	24283	39778	56833	88180							
86	3485	6203	9723	15899	24854	40715	58172	90256							
88	3566	6346	9947	16265	25426	41651	59510	92333							
90	3646	6489	10170	16630	25998	42588	60849	94410							
92	3726	6632	10394	16996	26570	43525	62187	96487							
94	3806	6774	10618	17362	27142	44462	63526	98563							
96	3886	6917	10842	17728	27714	45399	64864	100640							
98	3967	7060	11065	18094	28286	46336	66203	102717							
100	4055	7217	11312	18497	28915	47367	67676	105003							
102	4139	7367	11547	18882	29518	48354	69087	107191							
104	4228	7526	11795	19287	30152	49392	70570								
106	4317	7684	12044	19694	30787	50433	72058								
108	4407	7844	12294	20102	31426	51479	73551								
110	4497	8003	12544	20512	32066	52528	75051								
112	4587	8164	12796	20923	32709	53581	76555								
114	4677	8325	13048	21336	33354	54638	78065								
116	4768	8487	13301	21750	34001	55698	79580								
118	4864	8657	13569	22187	34685	56818	81180								
120	4956	8820	13824	22605	35337	57887	82707								
122	5047	8983	14080	23023	35992	58959	84239								
124	5140	9147	14337	23444	36649	60036	85777								
126	5237	9321	14609	23889	37345	61175	87405								
128	5330	9486	14868	24312	38007	62260	88955								
130	5428	9662	15143	24761	38709	63410	90598								
132	5522	9828	15404	25188	39376	64503	92160								
134	5621	10005	15681	25641	40085	65663									
136	5721	10183	15959	26097	40796	66829									
138	5816	10351	16224	26529	41472	67935									
140	5917	10530	16505	26988	42190	69111									
142	6018	10710	16787	27449	42911	70293									
144	6119	10891	17070	27913	43636	71480									
146	6222	11073	17355	28379	44364	72673									
148	6324	11256	17641	28847	45096	73872									
150	6433	11450	17946	29345	45874	75147									
152	6537	11634	18235	29817	46613	76357									
154	6647	11831	18543	30321	47400	77646									
156	6752	12017	18835	30798	48146	78869									
158	6864	12216	19146	31307	48942	80172									

\* Capacity in kilograms per hour of steam at 10% overpressure. Valve discharging to atmospheric pressure.

Capacities certified by the National Board of Boiler and Pressure Vessel Inspectors and in accordance with the ASME Boiler and Pressure Vessel Code, Section VIII.



# CROSBY J-SERIES

## DIRECT SPRING PRESSURE RELIEF VALVES

### SATURATED STEAM CAPACITIES, UNFIRED PRESSURE VESSEL SERVICE - Series JOS-E and JBS-E, Metric Units - Set Pressures 78 - 200 barg (CONTINUED)

Set pressure (barg)	Orifice letter designation and effective area, sq.mm.														
	D	E	F	G	H	J	K	L	M	N	P	Q	R	T	T2
<b>1 bar incr.<sup>2</sup></b>	<b>40</b>	<b>71</b>	<b>112</b>	<b>183</b>	<b>286</b>	<b>468</b>	<b>669</b>	<b>1038</b>	<b>1310</b>	<b>1580</b>	<b>2323</b>	<b>4021</b>	<b>5824</b>	<b>9465</b>	<b>10145</b>
<b>5 bar incr.<sup>2</sup></b>	<b>201</b>	<b>357</b>	<b>559</b>	<b>915</b>	<b>1430</b>	<b>2342</b>	<b>3346</b>	<b>5192</b>	<b>6552</b>	<b>7898</b>	<b>11641</b>	<b>20103</b>	<b>29119</b>	<b>47323</b>	<b>50726</b>
160	6976	12415	19459	31819	49742	81483									
162	7089	12616	19774	32334	50546	82801									
164	7202	12818	20090	32851	51356	84126									
166	7316	13021	20409	33372	52169	85459									
168	7431	13226	20729	33895	52988	86799									
170	7553	13443	21070	34453	53859										
172	7669	13650	21394	34982											
174	7793	13870	21739	35547											
176	7918	14092	22087	36115											
178	8043	14315	22436	36687											
180	8169	14540	22788	37263											
182	8304	14779	23163	37875											
184	8432	15006	23520	38459											
186	8568	15249	23899	39080											
188	8712	15506	24303	39740											
190	8851	15752	24689	40370											
192	8997	16014	25098	41040											
196	9295	16542	25927	42395											
200	9604	17093	26791	43808											

\* Capacity in kilograms per hour of steam at 10% overpressure. Valve discharging to atmospheric pressure.

Capacities certified by the National Board of Boiler and Pressure Vessel Inspectors and in accordance with the ASME Boiler and Pressure Vessel Code, Section VIII.

# CROSBY J-SERIES

## DIRECT SPRING PRESSURE RELIEF VALVES

---

### SERIES JOS-E-B/JBS-E-B PRODUCT OVERVIEW

---

Series JOS-E-B/JBS-E-B BlockBody valves provide greater capacity and can be set at pressures and temperatures significantly higher than the traditional design cast steel API Standard 526 relief valves. One single BlockBody installation has satisfied the capacity of twelve smaller valves.

The BlockBody design also adds significantly to the scope of materials that can be provided in accordance with ASME Code Section VIII by adding a wide array of wrought materials. Utilizing the BlockBody design, higher material integrity is offered which can minimize non-destructive examination (NDE) requirements.

BlockBody relief valves can be designed to unconventional sizes which can be an advantage when retrofitting to existing systems. Pressure relief valve outlet sizes can be increased beyond API standards to eliminate outlet piping reducers and mitigate built-up back pressure in the downstream piping.

### FEATURES

---

- Geometrically designed body and bonnet eliminates the need for multiple, smaller orifice cast steel API Standard 526 pressure relief valves.
- Provides significant weight reduction when compared to multiple smaller orifice PRVs.
- Significantly reduces inlet and discharge piping costs.
- Reduced downtime and maintenance.
- Fewer spare parts required.
- Specific inlet/outlet flange configurations and combinations available with unique center-to-face dimensions to meet existing systems.
- Forged body standard construction increases choice of materials available for harsh or corrosive service applications.
- Suitable for back pressure applications considerably beyond CI 300 service.
- Reliable and field proven design.



# CROSBY J-SERIES

## DIRECT SPRING PRESSURE RELIEF VALVES

### THE BLOCKBODY™ SCOPE OF DESIGN

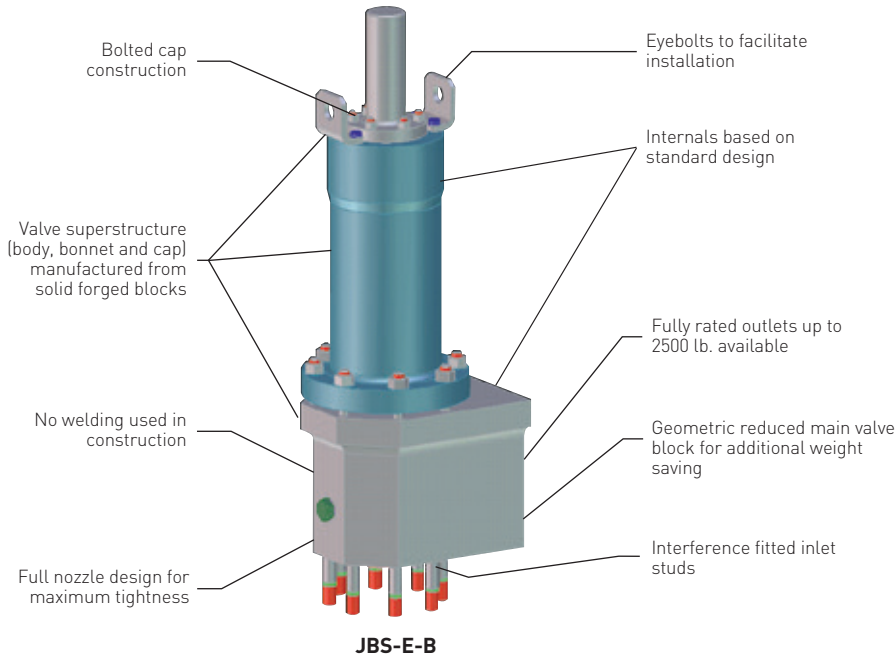

#### BLOCKBODY DESIGN

Typically, the valve housing (body, bonnet and cap) is manufactured from forged or other wrought materials. The body and/or bonnet are manufactured from a geometrically reduced block for additional weight reduction. Unless otherwise stated, all JOS-E/JBS-E BlockBody relief valves are supplied with a bolted cap to suit high pressure applications. BlockBody valves are manufactured to ASME Boiler and Pressure Code, Section VIII and relieving capacities are certified by the National Board of Boiler and Pressure Vessel Inspectors.

#### TYPICAL MATERIALS OF CONSTRUCTION

##### Body, bonnet and cap

- ASME SA105 carbon steel
- ASME SA182 grade F5a alloy steel
- ASME SA182 grade F9 alloy steel
- ASME SA479 type 316 stainless steel
- ASME SB348 grade 7 titanium
- ASME SA182 grade F51 Duplex stainless steel
- ASME SA479 UNS-S32550 super Duplex stainless steel
- ASME SA350 grade LF2 carbon steel
- ASTM B348 grade 4 titanium

##### Trim

- ASME SA479 type 316 stainless steel
- ASME SB425 UNS N08825 Incoloy 825
- ASME SB446 UNS N06625 Inconel 625
- ASME SA479 UNS S31803 Duplex stainless steel
- ASTM B348 grade 4 titanium

##### Spring

- High temperature alloy steel
- Titanium
- Inconel® X-750
- Chrome steel
- Type 316 stainless steel
- Hastelloy® B
- Hastelloy® C
- Monel®
- Alloy 20

#### ACCESSORIES AND OPTIONAL CONSTRUCTION

##### Accessories

- Lifting bracket
- Limit switch
- Actuator

##### Optional construction

- O-ring soft seat
- Special coating systems
- Steam purge
- Supplementary back pressure balancing piston

##### Connections

- Ring type joint inlet/outlet
- API 6BX 10,000# inlet
- Grayloc®
- Techlok®

##### NOTE

Inconel and Monel are registered trademarks of International Nickel Company. Hastelloy is a registered trademark of Haynes International. Grayloc is a registered trademark of Grayloc Products. Techlok is a registered trademark of Vector International.

# CROSBY J-SERIES

## DIRECT SPRING PRESSURE RELIEF VALVES

---

### ORDERING INFORMATION

---

The primary purpose of Series JOS-E/JBS-E/JLT pressure relief valves is to protect lives and property. To enable us to help you in selecting the right valve for your application, please provide the information listed below. Details of the process fluid and conditions are especially important. If there is any doubt as to selection or application of valves or parts, please contact your local sales representative.

For valve sizes 10" x 14" through 20" x 24", please refer to model JB datasheet VCTDS-00290.

Ordering information	Example
Quantity	5
Nominal valve size (inlet x orifice x outlet)	4 x L x 6
Valve series	JOS-E-45
Inlet connection rating and facing	600 RF
Outlet connection rating and facing	150 RF
Service (liquid, gas or vapor)	Air
Set pressure (psig)	800 psig
Back pressure (psig) if any and whether constant or variable	Atmosphere
Maximum service temperature (°F) ambient	60°F
Cap or lifting lever type	Type C
Valve materials	Standard
Seat material	Metal-to-metal standard
Code requirements	ASME Unfired Pressure Vessel Code, Section VIII
Required capacity	45433 SCFM
Accumulation (allowable overpressure)	10%
Molecular weight - vapor	-
Specific gravity - gases and liquids	1.0
Viscosity - liquids	-

### How to order examples

1. To specify a G orifice (0.503 in<sup>2</sup>.) (325 mm<sup>2</sup>) Style JOS conventional valve with standard materials for liquid service at 700 psig (48.2 barg) and at +700°F (+371°C) with a packed lifting lever, the following designation applies: 11/2 G 3 JLTJOS-E-46-D.
2. To specify an M orifice (3.60 in<sup>2</sup>.) (2323 mm<sup>2</sup>) Style JBS bellows valve with back pressure balancing piston, Monel<sup>®</sup> nozzle and disc insert, and Kalrez<sup>®</sup> O-ring soft seats for gas service at 200 psig (13.7 barg) and +400°F (+204°C) with threaded cap and test rod, the following designation applies: 4M6 JBSBP-E-OR-25-M1-K with Kalrez<sup>®</sup>.
3. To specify a K orifice (1.838 in<sup>2</sup>.) (1186 mm<sup>2</sup>) Style JOS conventional valve with open bonnet and standard materials for ASME Code Section VIII steam service at 600 psig (41.3 barg) and +600°F (+316°C) with a regular lifting lever, the following designation applies: 3K4 JOS-H-E-45-C.

# CROSBY J-SERIES

## DIRECT SPRING PRESSURE RELIEF VALVES

### SELECTION GUIDE

Example:	6Q8	JLTJBS-E	#	OR	4	5	R
<b>Inlet x orifice x outlet</b>							
<b>1D2</b>							
<b>To 12W16</b>							
<b>Valve series</b>							
<b>JOS-E</b>	Conventional						
<b>JBS-E</b>	Bellows						
<b>JLTJOS-E</b>	Conventional with liquid trim						
<b>JLTJBS-E</b>	Bellows with liquid trim						
<b>JBSBP-E</b>	Bellows with balancing piston						
<b>JLTJBSBP-E</b>	Bellows with liquid trim and balancing piston						
<b>JOS-H-E</b>	Conventional with open bonnet for ASME Code Section VIII steam service						
<b>High pressure Q and R orifice indication</b>							
<b>None</b>	Standard						
<b>#</b>	600# high pressure Q or R orifice						
<b>Seat type</b>							
<b>None</b>	Metal						
<b>OR</b>	O-Ring <sup>[1]</sup>						
<b>Inlet flange rating<sup>[4]</sup></b>							
<b>1</b>	150#						
<b>2</b>	300# (Light)						
<b>3</b>	300#						
<b>4</b>	600# <sup>[2]</sup>						
<b>5</b>	900#						
<b>6</b>	1500#						
<b>7</b>	2500#						
<b>X</b>	Other						
<b>Temperature range<sup>[4]</sup></b>							
<b>2</b>	-450°F to -76°F (-268°C to -60°C)						
<b>4</b>	-75°F to -21°F (-59°C to -30°C)						
<b>5</b>	-20°F to 650°F (-29°C to 343°C)						
<b>6</b>	651°F to 800°F (344°C to 427°C)						
<b>7</b>	801°F to 1000°F (428°C to 538°C)						
<b>X</b>	Other						
<b>Flange facing</b>							
<b>None</b>	(Standard) RF x RF						
<b>R</b>	RTJ x RF						
<b>T</b>	RTJ x RTJ						
<b>X</b>	Other						

### Model # Examples

1D2JOS-E15J  
 1D2JOS-E15LTJ  
 1.5F2JBS-E25SJ  
 4P6JLTJBS-E45SRD-PN2  
 3J4JBS-E75XXL-PBSPL  
 6Q8JBS-EX5XC-SPL

### NOTES

- When ordering soft seats, specify material according to page 3.
- Except 'T' and 'T2' orifices. These have 300# inlet flange.
- JOS-H-E may be used up to 800°F (427°C).
- See pages 22-55 for appropriate maximum set pressures, temperatures and outlet flange.
- Refer to page 20 for ASME Code Section VIII requirements regarding lifting lever.
- Contact sales representative for compliance to NACE MR0175-2003 or later.
- More than one model number supplement can be used at once.
- Only applies to non-NACE applications.
- See pages 13 and 14 for NACE MR0175-2002 materials of construction.

# CROSBY J-SERIES

## DIRECT SPRING PRESSURE RELIEF VALVES

### SELECTION GUIDE (continued)

Example	L6	D	-	PN2
<b>Material variations</b>				
<b>None</b>	Standard materials			
<b>C6</b>	CS body and bonnet and bonnet/316 SS trim/Inconel® X750 spring <sup>[6]</sup>			
<b>S4</b>	CS body and bonnet/316 SS trim/Ctd. chrome steel spring			
<b>S6</b>	SST body and bonnet/316 SS trim/Inconel® X750 spring			
<b>S</b>	SST body and bonnet/316 SS trim/316 spring			
<b>LT</b>	Low temp CS body and bonnet/SST trim/Ctd. chrome steel spring			
<b>L6</b>	Low temp CS body and bonnet/SST trim/Inconel® X750 spring			
<b>M1</b>	CS body and bonnet/SST and Monel® trim/Ctd. chrome steel spring			
<b>M4</b>	CS body and bonnet/Monel® trim/Ctd. chrome steel spring			
<b>M5</b>	Monel® body and bonnet/Monel® trim/Ctd. chrome steel spring			
<b>M6</b>	Monel® body and bonnet/Monel® trim/Inconel® X750 spring			
<b>M</b>	Monel® body and bonnet/Monel® trim/Monel® spring			
<b>H1</b>	CS body and bonnet/SST and Hastelloy® Trim/Ctd. chrome steel spring			
<b>H4</b>	CS body and bonnet/Hastelloy® trim/Ctd. Chrome steel spring			
<b>H5</b>	Hastelloy® body and bonnet/Hastelloy® trim/Ctd. chrome steel spring			
<b>H6</b>	Hastelloy® body and bonnet/Hastelloy® trim/Inconel® X750 spring			
<b>H</b>	Hastelloy® body and bonnet/Hastelloy® trim/Hastelloy® spring			
<b>XX</b>	Other			
<b>Cap and lifting lever type<sup>[6]</sup></b>				
<b>J</b>	(Standard) threaded cap			
<b>K</b>	Threaded cap with test rod			
<b>C</b>	Regular lifting lever			
<b>D</b>	Packed lifting lever			
<b>E</b>	Packed lifting lever with test rod			
<b>L</b>	Bolted cap			
<b>M</b>	Bolted cap with test rod			
<b>A</b>	Threaded cap (restricted height)			
<b>B</b>	Threaded cap with test rod (restricted height)			
<b>G</b>	Bolted cap (restricted height)			
<b>H</b>	Bolted cap with test rod (restricted height)			
<b>T</b>	Regular lifting lever with test rod and Type K with test rod			
<b>X</b>	Other			
<b>Model number supplement indicator</b>				
<b>None</b>	No model number supplement(s) if model number supplement is present			
<b>Model number supplements<sup>[7]</sup></b>				
<b>P</b>	PED Certification			
<b>N2</b>	NACE MR0175-2002 Edition <sup>[6,9]</sup>			
<b>S</b>	Steam trim set pressure above 450 psig			
<b>B</b>	Forged block body configuration			
<b>SPL</b>	Non-standard option or configuration			

### NOTES

1. When ordering soft seats, specify material according to page 3.
2. Except 'T' and 'T2' orifices. These have 300# inlet flange.
3. JOS-H-E may be used up to 800°F (427°C).
4. See pages 22-55 for appropriate maximum set pressures, temperatures and outlet flange.
5. Refer to page 20 for ASME Code Section VIII requirements regarding lifting lever.
6. Contact sales representative for compliance to NACE MR0175-2003 or later.
7. More than one model number supplement can be used at once.
8. Only applies to non-NACE applications.
9. See pages 13 and 14 for NACE MR0175-2002 materials of construction.

# CROSBY J-SERIES

## DIRECT SPRING PRESSURE RELIEF VALVES

### ORDERING INFORMATION - PARTS

To order parts, the following information should be included:

1. Quantity
2. Part name, i.e., disc insert
3. Size, series and valve number
4. Shop number (from valve nameplate)\*
5. Serial number (from valve nameplate)
6. Original purchase order number (if shop number has been destroyed).

\* For valves manufactured in 2012 or earlier.

Pentair Valves & Controls provides a special 'fast response' delivery service of spare parts to satisfy unplanned requirements which can be initiated by contacting your local representative.

Emergency delivery service is available direct from the factory, 24 hours a day, 7 days a week.

#### Springs with washers

To order springs with washers, in addition to the other information included for 'parts', the required valve set pressure must also be specified. If the spring is for a non-bellows valve and there is a constant back pressure condition, that should also be specified as should the spring material, if other than standard.

#### Replacement valves

To replace a valve in service, the shop number, serial number, set pressure and previous order number should be specified.

ANDERSON GREENWOOD CROSBY, STAFFORD TX			
SIZE STYLE		1D2 JOS-E15J	
SET PRESS.		100 PSIG	CDTP 91 PSIG
SER. NO.	12345678	BP 10 PSI	TC 1
CAP.	245 SCFM @ 60F		OVER PRESS. 10%

SAMPLE NAMEPLATE  
(figures shown are for illustrative purposes only)

## CROSBY J-SERIES

### DIRECT SPRING PRESSURE RELIEF VALVES

---

#### PRESSURE RELIEF DEVICE SIZING AND SELECTION SOFTWARE

---

Pentair PRV<sup>2</sup>SIZE incorporates over 135 years of experience and engineering expertise for an extensive array of Anderson Greenwood, Crosby and Varec pressure relief devices and related products in one software package. It enables you to address numerous applications in a single sizing and selection platform without the need to use two or more sizing programs.



Pentair PRV<sup>2</sup>SIZE features:

- User-friendly interface
  - Sizing calculations can be saved at any point
  - Multiple tags can be opened at one time
- Ability to sort data using a variety of parameters
- Fully configured product selection
- Industry standard sizing methodologies
- Drop-down boxes allow instantaneous change of sizing methodology from API to ASME and vice -versa
- 2:1 elliptical head tanks for fire sizing applications
- Catalog integration from existing product literature PDF's
- Detailed product specifications including cross sectional drawings with dimensions and weights
  - U.S. customary system and metric units
- Advanced tools to export and import device tag numbers with the ability to mail files directly from the software program
- Flow curves for pressure relief valves
- Individual capsule summaries of each product including an image of the selected product

Pentair PRV<sup>2</sup>SIZE website: [valvesizing.pentair.com](http://valvesizing.pentair.com)



#### PENTAIR VALVES & CONTROLS

[www.pentair.com/valves](http://www.pentair.com/valves)

All Pentair trademarks and logos are owned by Pentair plc. All other brand or product names are trademarks or registered marks of their respective owners. Because we are continuously improving our products and services, Pentair reserves the right to change product designs and specifications without notice. Pentair is an equal opportunity employer. © 2015 Pentair plc. All rights reserved.